

## Robotic Pill Dispenser

<sup>1</sup>Albert Jaison, <sup>2</sup>Anu Simon, <sup>3</sup>Arun Christin, <sup>4</sup>Neethu John, <sup>5</sup>Nisha Varghese,  
<sup>6</sup>Mr.Yuvaraj.V

<sup>1,2,3,4,5</sup> student, Department of Biomedical Engineering, Sahrdaya College of Engineering & Technology,  
Thrissur-17, Kerala, India,

<sup>6\*</sup> Assistant Professor, Department of Biomedical Engineering & Technology, Thrissur-17, Kerala, India,

---

**Abstract:** Most often people regardless of whether they are old or young tend to forget their medicines. Timely medication is very necessary for the cure of any disease. An automatic pill dispenser with the ability to distribute multiple pills for a certain patient or a private individual can allow more attention to be given to patients and elderly to remember when and what dosage of their medication to be taken. The heart of our project is the pill dispenser which is the model of a circular drive which has four compartments to place the medicine during four times a day. Our project uses PIC16F877A as our main microcontroller. The dispenser also has a LCD display to display the medication system and medication time is alerted by the alarm. The whole pill dispenser can be movable which is controlled by a remote control. As future work we plan to control robot through voice control and reminder system for refilling the medicines.

**Index terms:** XBee Module, Stepper motor driver, Servo motor driver, Real time clock

---

### I. Introduction

THE robotic pill dispenser is based on the principle of automatically reminding patient to take their pills on time using a timer algorithm. The main feature of this project is that it can dispense pills to multiple patients. This is made possible by controlling the motion of the robot using a remote control. The remote works with the help of an XBee module which is a Transceiver that communicates through radio frequency. We used PIC16F877A as our main microcontroller as it very reliable, low cost and can be easily interfaced with multiple peripherals.

For a automatic pill dispenser a mechanical model that efficiently provide the pills at the required time. The pill provider model should be properly synchronized with the timer module. For achieving this we made cylinder of glass which is divided into four compartments. This cylinder is attached to the stepper motor which controlled by microcontroller through a micro stepper driver that provide precise micro step rotation of stepper motor. So as stepper motor rotates the cylindrical rotates simultaneously. A real time is the most important part of our project that gives the exact time of pill dispenser rotation. A rover is also present that is controlled by a remote through radio frequencies which makes our pill dispenser movable.

Firstly we made algorithm for the automatic pill dispenser. Then we designed our mechanical model and interfaced all the software part and the hardware part with it. Then we made the algorithm for the remote control and made the rover model and done the software and hardware interfacing. Thirdly we attached the rover section with the automatic pill dispenser which made our project a movable automatic pill dispenser which is very robust and efficient that can be used easily for providing timely medication to patients.

### II. Literature Survey

Robotic pill dispenser aims to distribute pills to the patients or elders at required time easily and efficiently. For not taking pill at required time and dosage leads to health complications especially diabetic patients whose need accurate time for pills. According to administer of ageing one of the main leaders admitting to hospital is mismanagement of medicines. Pill dispenser allows for an in home care provider to regulate patients medication without constantly monitoring the patient. Since many patients are required to take multiple pills so pill dispenser need separate compartments either arranging pills for a particular time or separate compartments for each pills. Our project the pill dispenser consists of four compartments that is to be filled according to time of pills and to be refilled every day.

Need of pill dispenser is most important for patients that takes in multiple pills as pill medication get easily distracted due to phone calls, knock on door etc.. These distractions confuse the patient on which pills have been taken in or which pill not taken. Pill dispenser is less time consuming as it reduces time on reading labels which are often difficult to read and often written in small letters.

In recent years assistive robot has emerged as increasing field of research and development. The robotic platform is used to test several ideas like intelligent reminding system, companion, social interaction etc.

for physically impaired and elderly people in the society [1]. Robotic pill dispenser is an intelligent reminder system that reminds pill time by alarm system and provides required pills at required dosage.

Therefore automatic pill dispenser allows patients to spent time a better quality of life without held captive by confusing and often tiresome process of taking medication on schedule.

### III. Methodologies

Our project aims to provide an easy tool for pill medication. ROBOTIC PILL DISPENSER is a movable automatic pill dispenser that is able to provide pills at required time. The main features of our project are:

- Four separate pill compartments for four different pill times.
- Rotatable pill dispenser that can provide pill at required times of a day.
- The movement of the pill dispenser can be controlled remote control wirelessly using radiofrequency waves.

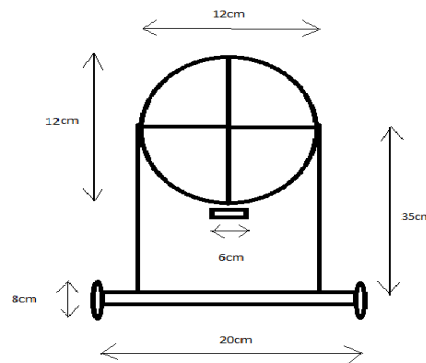

Fig .1. Schematic diagram front view

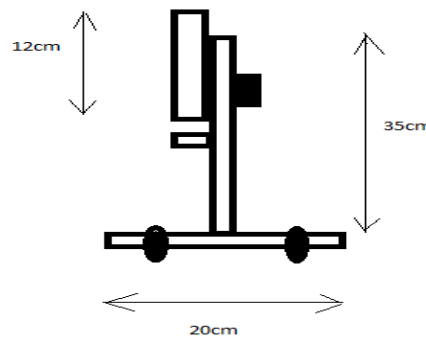

Fig .1.schmatic diagram side view

The proposed project consists of an automatic pill dispenser placed over a rover of four wheels which is controlled by a remote control wirelessly by radiofrequency waves. The automatic pill dispenser consists of four by four matrix switch buttons for adjusting time and viewing the pill times. PIC16f877A is the main microcontroller of our project. We used three types of motor a) two geared DC motor for movement of rover b) one servo motor movement of pill plate c) one stepper motor for controlling the pill dispenser. Stepper motor is controlled by ICA3967 micro stepper driver. Other three motors are controlled by L293D driver IC. DS1307 is real time clock that give pill time to the microcontroller. Xbee transceiver will transmit direction of movement from remote to the pill dispenser. 16\*2 lines LCD display showing the pill time and alarm system for alerting the patients on pill time. These are the main components of robotic pill dispenser.

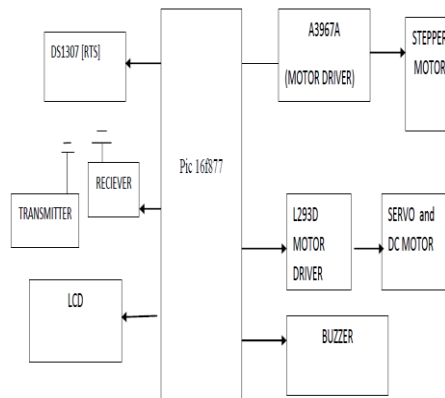

Fig.3.Block diagram

#### IV. Algorithm

##### 5.1 Algorithm For Pic1

- Step: 1 Start
- Step: 2 Initialize UART, RTC and LCD
- Step: 3 Set count = 4 and set the current time in RTC
- Step: 4 Set the four pill times and display "PILL TIME" in LCD
- Step: 5 Call to Step: 11
- Step: 6 If 1st pill time is set decrement the count and run servo motor, else call Step: 11
- Step: 7 If 2nd pill time is set decrement the count and run servo motor, else call Step: 11
- Step: 8 If 3rd pill time is set decrement the count and run servo motor, else call Step: 11
- Step: 9 If 4th pill time is set decrement the count and run servo motor, else call Step: 11
- Step: 10 Jump to Step: 3
- Step: 11 If count = 4 then go to Step: 15, else jump to Step: 6.
- Step: 12 If count = 3 then go to Step: 15, else jump to Step: 7.
- Step: 13 If count = 2 then go to Step: 15, else jump to Step: 8
- Step: 14 If count = 1 then go to Step: 15, else jump to Step: 9
- Step: 15 Return.
- Step: 16 If any signal is received from the UART of PIC 2, then go to Step: 17 else go to Step: 21
- Step: 17 If forward is received run motor1 and motor2 clockwise and display "FORWARD" on the LCD else go to Step 18
- Step: 18 If backward is received run motor1 and motor2 anti-clockwise and display "BACKWARD" on the LCD else go to Step 19
- Step: 19 If right is received run motor1 clockwise and display "RIGHT" on the LCD else go to Step20
- Step: 20 if left is received run motor2 in anti-clockwise and display "LEFT" on the LCD else go to Step 21
- Step: 21 Return
- Step: 22 Stop

##### 5.2 Algorithm For Pic 2

- Step: 1 Start
- Step: 2 Initiate UART and LCD
- Step: 3 Display "remote control" LCD
- Step: 4 Initiate character "a"
- Step: 5 If a=1 ,then display 'forward' and send "forward" through UART PIC 1, else go to step: 6 .
- Step: 6If a=1 ,then display 'backward' and send "backward" through UART PIC 1, else go to step:7.
- Step: 7If a=1 ,then display 'right' and send "right" through UART PIC 1, else go to step8 .
- Step: 8If a=1 ,then display 'left' and send "left" through UART PIC 1, else go to step9 .
- Step: 9 Jump to step 3.
- Step: 10 Stop.

## V. Result And Discussion

Our project titled “Robotic Pill Dispenser” was completed successfully and we obtained the required result output. The main feature of our project is to help in the timely disposal of pill at the correct timings by alerting the patients. During the execution and implementation of our product we learnt the different features of PIC16f877A. We learnt to write a C program into PIC using the software MPLAB 8.6 and the PCB simulation was done using the software ISIS Proteus. We also learnt how to interface PIC with stepper motor, servo motor, LCD display, ZIGBEE module and alarm system. The interfacing of the stepper motor with PIC16f877A was done using the driver IC L293D. A 16\*2 LCD display was used to display the medication details that are required for patient intake. We also learnt to program the servo motor for controlled and timed rotation. We were successfully able to complete the hardware design and mechanical modeling of our product to make it completely operative. We learnt the applications of ZIGBEE module which we have used in implementing our project for remote transmission and reception to control the movement of the “Robotic pill dispenser”. We designed a remote control for operating the movement of the “Robotic Pill Dispenser” with the help of ZIGBEE module which is programmed using PIC16f877A.

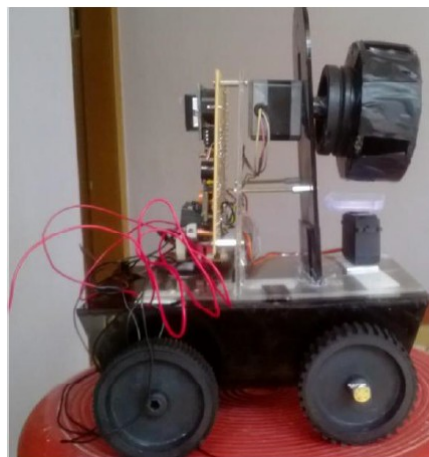

Fig.4 Side view of our project

## VI. Conclusion

Our project is based on creating a robotic pill dispenser. We proposed this project as it is very important to take medication on time. Most often people regardless of whether they are old or young tend to forget their medicines. Timely medication is very necessary for the cure of any disease. With the help of our project we aim to tackle the problem of timely medication.

Our project team selected a project that applies to the pharmaceutical and medical field of engineering that incorporates the use of mechanical and mechatronic systems. It was decided that since many hospitals have experienced the effects caused by low nurse to patient ratios, a robotic pill dispenser would prove to be a very useful tool. An automatic pill dispenser with the ability to distribute multiple pills for a certain patient or private individual can allow more attention to be given to patients and elderly to remember when and what dosage of their medication to be taken.

## Reference

- [1] I'll keep an Eye on You: Home Robot Companion for Elderly People with Cognitive Impairment By H.-M. Gross, Ch. Schroeter, S. Mueller, M. Volkhardt, E. Einhorn, A. Bley, T. Langner, Ch. Martin, M. Merten.
- [2] Elizabeth Broadbent, Rie Tamagawa, Ngaire Kerse, Brett Knock, Anna Patience, and Bruce MacDonald, "Retirement home staff and residents' preferences for healthcare robots", 18th IEEE International Symposium on Robot and Human Interactive Communication, 2009.
- [3] Smart Medication Dispenser: Design, Architecture and Implementation- Pei-Hsuan Tsai, Tsung-Yen Chen, Chi-Ren Yu, Chi-Sheng Shih, Member, IEEE, and Jane W. S. Liu, Fellow, IEEE.