

Experimental and Numerical Analysis of Testing Wheel Rim

Shubham V. Dongare¹, Sandeep G. Thorat², Dr. Sudarshan Sanap³

¹(M. Tech Student, Mechanical Engg Dept. MIT ADT University, Pune, India)

²(Assistant Professor, Mechanical Engg. Dept., MIT ADT University, Pune, India)

³(HOD, Mechanical Engg. Dept., MIT ADT University, Pune, India)

Corresponding Author: Shubham V. Dongare

Abstract: The purpose of the testing wheel rim provider firm base on that to suit the tire. Its dimensions, form ought to be appropriate to adequately accommodate the actual tire needed for the vehicle during this study a tire of testing wheel rim happiness to the disc wheel class is taken into account style in a vital industrial activity that influences the standard of the merchandise. The wheel rim is intended by exploitation modeling code catia v5r18. In modeling the time spent in manufacturing the advanced 3D models and therefore the risk concerned in style and producing method will be simply decreased that the modeling of the wheel rim is created by exploitation CATIA. Later this CATIA model is foreign to ANSYS fourteen for analysis work. ANSYS code is that the latest used for simulating the various forces, pressure working on the part and additionally for hard and viewing the results. A problem solver mode in ANSYS code calculates the stresses, deflections, bending moments and their relations while not manual interventions, reduces the time compared with the strategy of mathematical calculations by a personality's. ANSYS static analysis work is testingried out by thought-about testing wheel rim materials and their relative performances are discovered severally. Additionally to the present rim is subjected to vibration analysis (modal analysis), a district of dynamic analysis is testingried out its performance is discovered. Then once this testing wheel rim has been manufacture in plant and every one style parameter can follows the EUROPIAN TIRE AND RIM TECHNICAL ORGANISATION (ETRTO). That factory-made testing wheel rim has quality checked and experiment. The experimental results has compare with the numerical result.

Date of Submission: 20-08-2019

Date of Acceptance: 04-09-2019

I. Introduction

A wheel edge is AN exceptionally targeted on phase in a very automobile that's exposed to twisting and torsional masses. On account of the long life and high worries, even as the necessity for weight decrease, material and collection method alternative is vital in edge set up. There are rivalries among materials and collection forms, thanks to price execution, and weight. this is often a right away consequence of trade interest for segments that are lighter, to expand proficiency, and fewer valuable to deliver, whereas within the in the meantime maintaining temporary state quality and different utilitarian stipulations within the weakness life assessment of mellow steel testing wheel edge structure, the commonly acknowledged methodology for individual vehicle wheel manufacturing is to complete 2 solidness tests, to be specific the spiral exhaustion check and cornering temporary state test. Since testing wheels are meant for selection fashionable and have additional fascinating shapes than normal steel wheels, it's exhausting to judge temporary state life by utilizing diagnostic techniques. The recently structured wheel is tried in research laboratory for its life through a quickened in sight of those check the wheel configuration is in addition modified for top quality. In any case, stress investigation won't yield the best wheel configuration represented a probability based mostly model for forecast of weakness disappointment of wheel edge. Basic steel are the 3 vital materials by that fringe of wheel is threw and afterward manufactured from testing wheel edge. By directional structure of examinations best constant set up ought to be potential. in addition thickness of the sting will be fluctuated for each one in all these materials. it's begun that by shifting the thickness level we are able to get fluctuated temporary state quality. it's prescribed to utilize ideal thickness which provides higher quality while not commercialism off the weakness lifetime of the sting. such a large amount of analysisers research on the on the sphere of car wheel rim in order that Manivannan r et. al. has been analysis on reduction of weight of a vehicle wheel, their analysis on by implementing totally different peek composites they found that peekâ€“90 hmf twenty suits the most effective for factory-made the wheel rim material. Jufu Jiang et. al was ready on the wheel edge material mechanical propertiesand microstructure of the AZ91D metallic element amalgam cruiser wheels framed by twofold management shaping and bite the dirt throwing and therefore the micrographs that the high weight led to by production framework ends up in clear grain refinement of the essential a-Mg and uniform dissemination of the mixture comprising of the eutectic a-Mg and b-Mg Al. M. Yaman and B.Yegin was found that on the rhythm of

sunshine business vehicle wheel talking to the dynamic conduct of real structure is 425 Hertz. fifteen Hertz repeat has been relinquished from crucial traditional recurrence for brand new set up alteration proposal yet new key recurrence was heretofore additional outstanding than 350 Hz that is within commotion limit. VajjaSai Ram et. al. was investigation on the steady burden is connected on R16" edge with and while not utilization of Nano covering. Alexandruvalentinradulescu et. al. was found that dispensing with the middle of stresses and increasing the unwavering quality of the sting thermoplastic resin ThejaM et. al. has been investigation on the design of recent and higher edge structure with thought of lightweight weight and what is more recreating the mixture wheel models of new and existing models as for static and temporary state examination for locating the von misses pressure and exhaustion lifetime of the models. The tire rim in as a wheel merely once it's established on the sting and is enlarged accordingly; the tire and wheel get along influences the capability and execution of the vehicle. The tire is planned and created to suit a customary edge and once introduced on the correct edge rim, the tire can perform up to its favored dimension. it's clearly that the lifetime of the tire are going to be diminished within the event that it is introduced on AN dissatisfactory rim. Once the disc plate is mounted within the cylinder this assembly becomes a wheel. SenKailuteciomet. al. has been found that the foremost extreme pressure was 229.5 MPa, that was set within the center purpose jolt openings territory concurred with the truth. The ostensible pressure technique was utilised to foresee the weakness lifetime of atomic number 13 HS6061-T6 compound edges. ChoudhuryDipeshRohan has been broken away at structure and investigation of to create up a composite wheel edge to be utilised with a light-weight atomic number 13 focus to minimize the unsprang mass of the vehicle and during this manner decline the suspension response time for additional noteworthy management of the vehicle. this may move within the direction of transferral the sprung to unsprung mass proportion nearer to the primary esteem, and consequently take into thought additional decrease of the unsprung mass even as sprung mass. Mr.SasankShekhar Panda has found that the current set up is hr lighter than the primary structure. In their work the overall measurements are strained by decreasing range of spokes to the mixture wheel with same operating strength and less weight. D. Santhosh Kumar et. al. was improvement on the mass of the hub rim through the employment of finite component analysis. the edges are analyzed in ANSYS by exploitation 3 kinds of materials (i.e., Al alloy, Mg alloy and steel alloy). Daniel Anthony C and patrician Father patron saint J have additionally style and analysis On the 2 wheeler alloy rim with the composite materials. PratyushDeshmukh has improvement of mass of wheel rim of significant vehicles. Their primary objectives was to decreases the burden if the wheel by that the general performance and potency of the vehicles was enlarged. usually the shapes of the overall rim vehicle are created up drop centre rim, wide drop centre rim and wide drop center rim with hump.

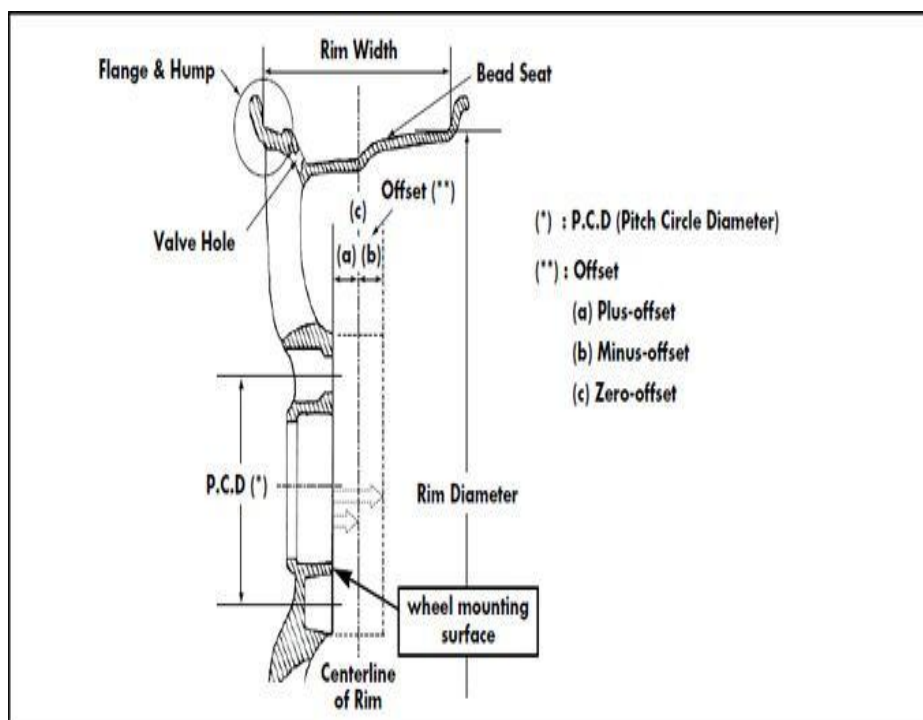

Fig1: RimNomenclature

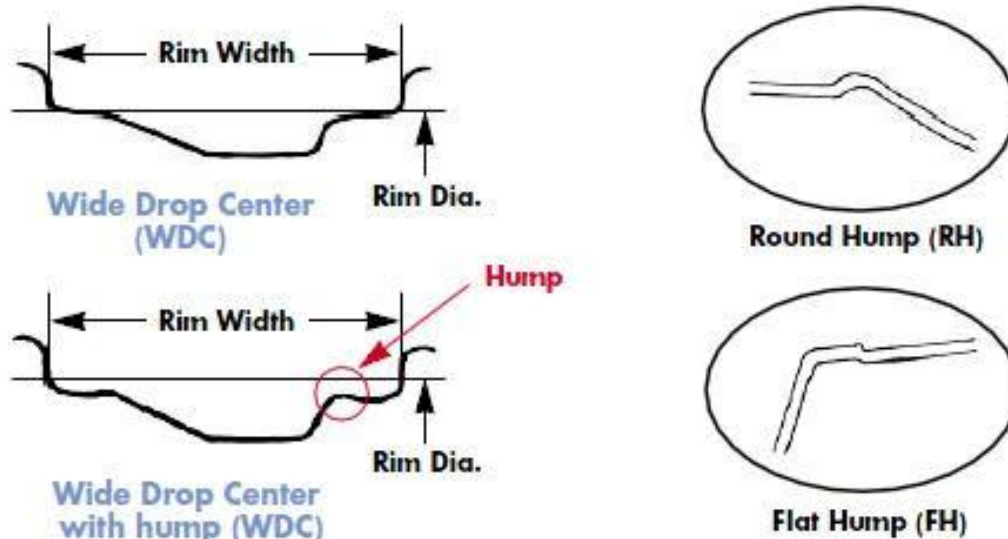

Fig 2: Wide DropCentre(Dc)Rim with hump

Steel and light-weight alloy are the foremost materials employed in a wheel rim but some composite materials beside glass-fiber are being employed for special wheels. Wire spoke wheel is an important wherever the outside edge half of the wheel (rim) and therefore the shaft mounting part are joined by various wires referred to as spokes. Today vehicles with their high HP have created this kind of wheel manufacture obsolete. this kind of wheel remains used on classic vehicles. Another rim that practices the steel-made rim and therefore the wheel into one by connexion (welding), and it's used principally for traveler vehicles particularly original instrumentality tires. Alloy wheels are supported the employment of sunshine metals, like atomic number 13 and metallic element has return to be well-liked within the market. The benefits of every lightweight alloy wheel material are as atomic number 13 alloy, metallic element alloy, metallic element alloy and composite materials. During this paper wear down the analysis of testing wheel rim and therefore their strength and the method of producing of testing wheel rim manufacturing.

II. Numerical Analysis of Testing Wheel

The finite component methodology could be a powerful tool for the numerical procedure to get solutions to several of the issues encountered in engineering analysis. Structural, thermal and warmth transfer, fluid dynamics, fatigue connected issues, electrical and magnetic fields, the ideas of finite component strategies will be utilised to unravel these engineering issues. during this methodology of study, a fancy region shaping a time is discretized into easy geometric shapes referred to as finite parts the domain over that the analysis is studied is split into variety of finite elements. the fabric properties and therefore the governing relationship are thought-about over these parts and expressed in terms of unknown values at component corner .An assembly method, punctually considering the loading and constraint, ends up in set of equation. resolution of those equations offers the approximate behavior of the time. ab initio the second drawing of wheel rim is finished by exploitation CATIA in step with dimensions per the Table-1.

Table No. 1 Wheel Rim Design Parameters (8JX19)

Outer diameter	482.6 mm
Hub hole diameter	125 mm
Bolt hole diameter	16 mm
Rim width	203.2 mm
Wheel Type	J Type

3D model of testing wheel rim

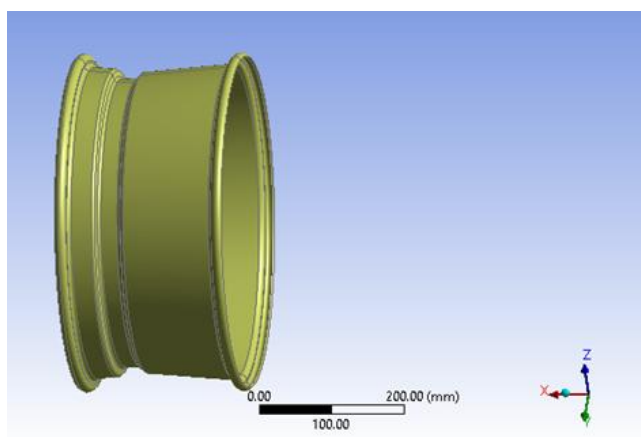

Fig: 3- 3D Model of the wheel rim

The process of generating a mesh of nodes and elements consists of three general steps.

1. Set the element attributes.
2. Set mesh controls (optional).
3. Meshing model.

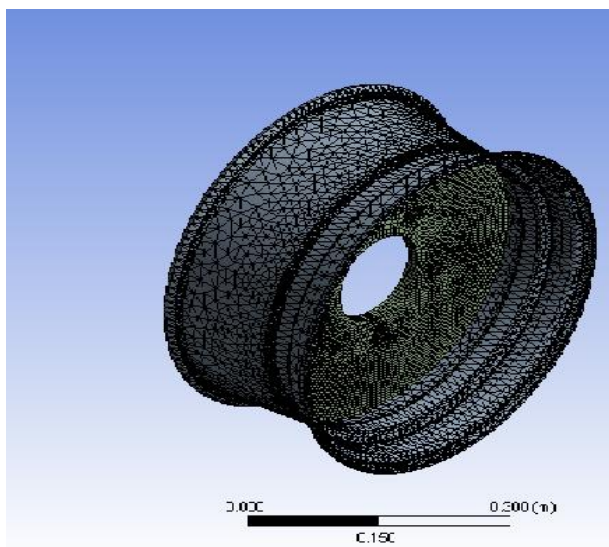

Figure : 4- Mesh of Testing wheel rim

Finite Element Analysis

We have studied the rim Analysis with constant tire inflation pressure 40 Psi (275.79Kpa) and Variation in radial load applied on rim. As tire inflation pressure is one of the constant force acting on rim throughout its working conditions, while the radial load acting on rim is variable. In order to evaluate the performance of rim for different radial load, analysis carried out with constant tire inflation pressure o 275.79 Kpa and different radial load employed on rim as follows:

1. 150 kg
2. 225 kg
3. 300 kg

A1] Analysis under Inflation Pressure of 275.79 kpa and Load 150kg-From displacement plot it can be seen that the displacement or strain in Rim is negligible, the maximum strain value is 0.000344 which is observed in well area of Rim. While the maximum VonMises **stress value is 68.75 MPa and minimum stress value is 0.17325 MPa.**

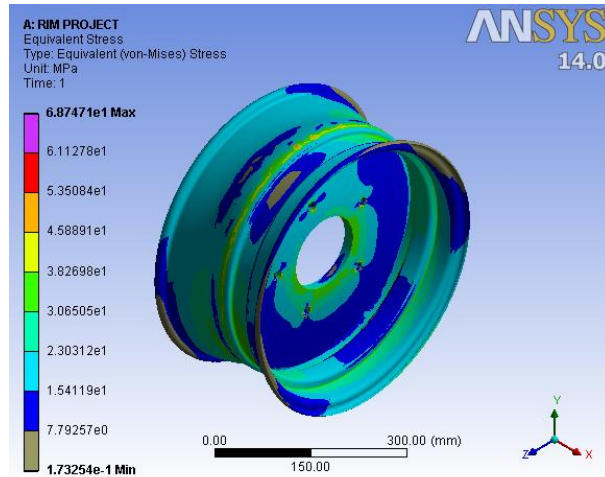

Fig.5. Von-Mess Stress plot at 275.79 kpa pressure 150kg load

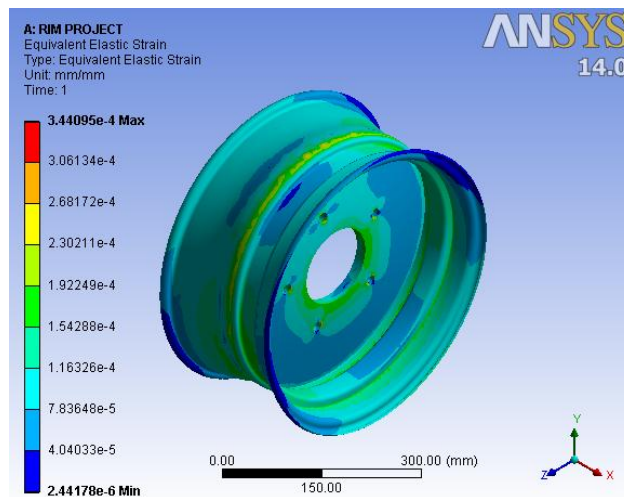

Fig. 6 Displacement plot at 275.79 kpa pressure 150kg load

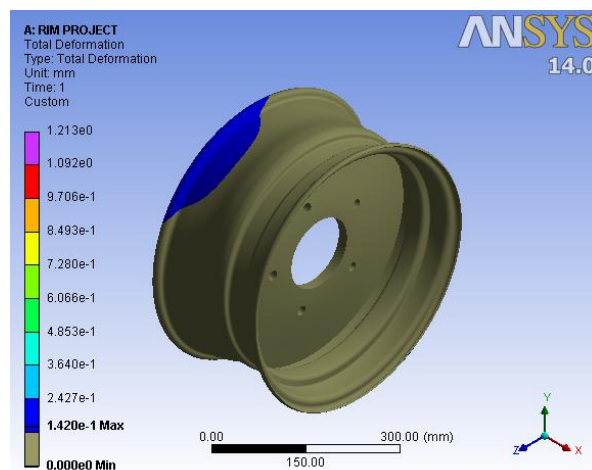

Fig. 7. Total Deformation plot at 275.79 kpa pressure 150kg load

A2] Analysis under Inflation Pressure of 275.79 kpa and Load 225 kg

From displacement plot it can be seen that the displacement or strain in Rim is negligible, the maximum strain value is 0.003522 which is observed in well area of Rim. While the maximum Von Mises stress value is 70.38 MPa and minimum stress value is 0.1665 MPa.

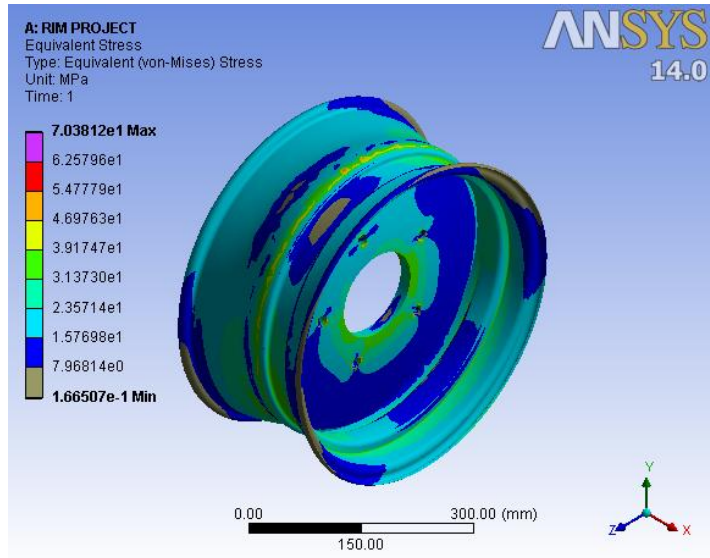

Fig. 8. Von-Mess Stress plot at 275.79 kpa pressure 225 kg load

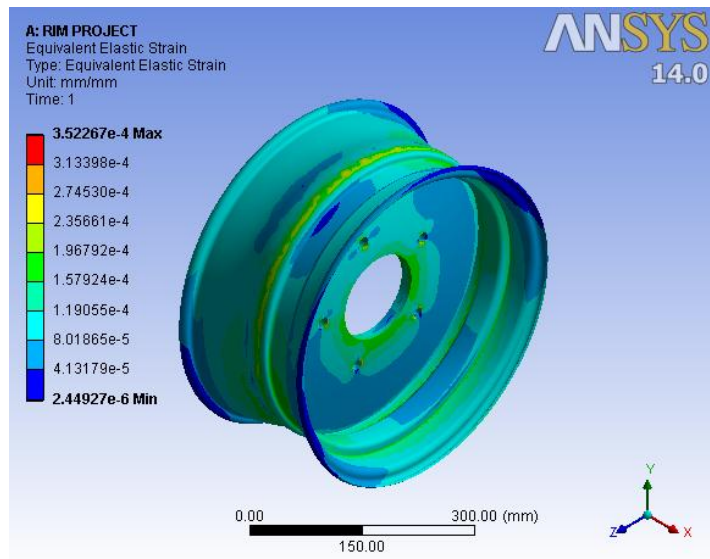

Fig. 9. Displacement plot at 275.79 kpa pressure 225 kg load

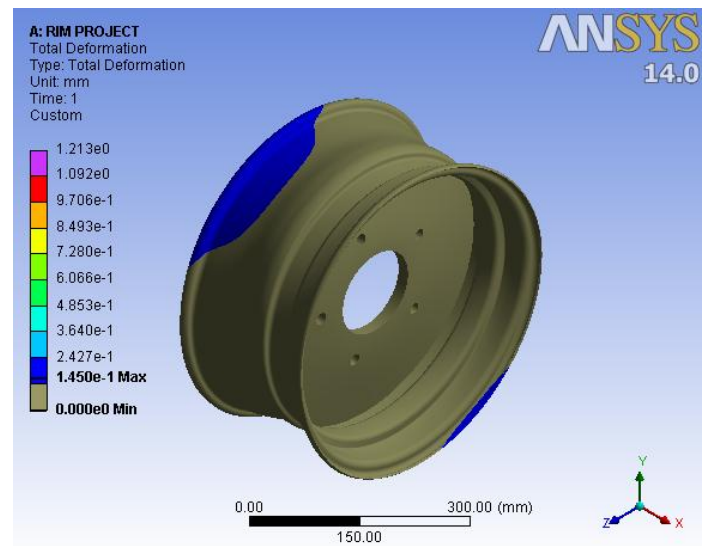

Fig. 10. Total Deformation plot at 275.79 kpa pressure 225 kg load

A3] Analysis under Inflation Pressure of 275.79 kpa and Load 200kg . Pressure load 200kg.

From displacement plot it can be seen that the displacement or strain in Rim is negligible, the maximum strain value is 0.0036 which is observed in well area of Rim. While the maximum Von Mises stress value is 72.02 MPa and minimum stress value is 0.184 MPa.

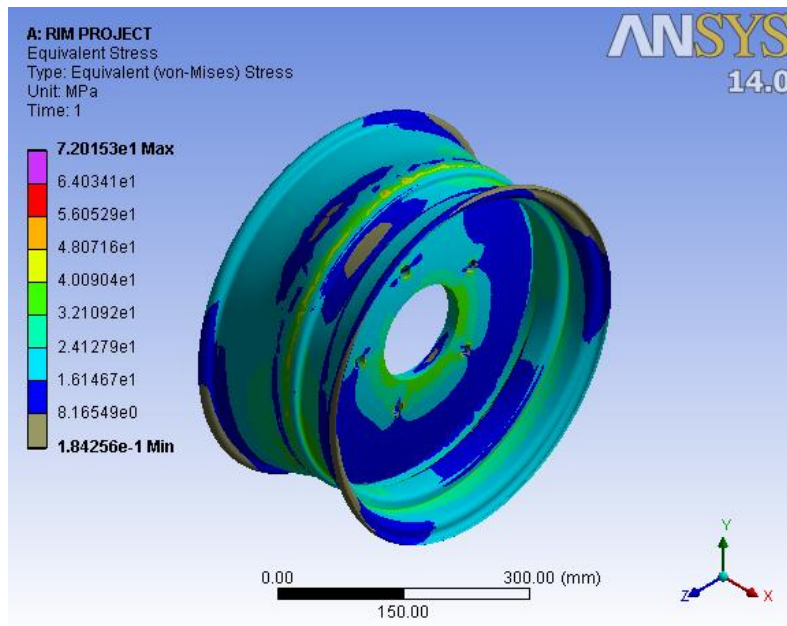

Fig. 11. Von-Mess Stress plot at 275.79 kpa pressure 300 kg load

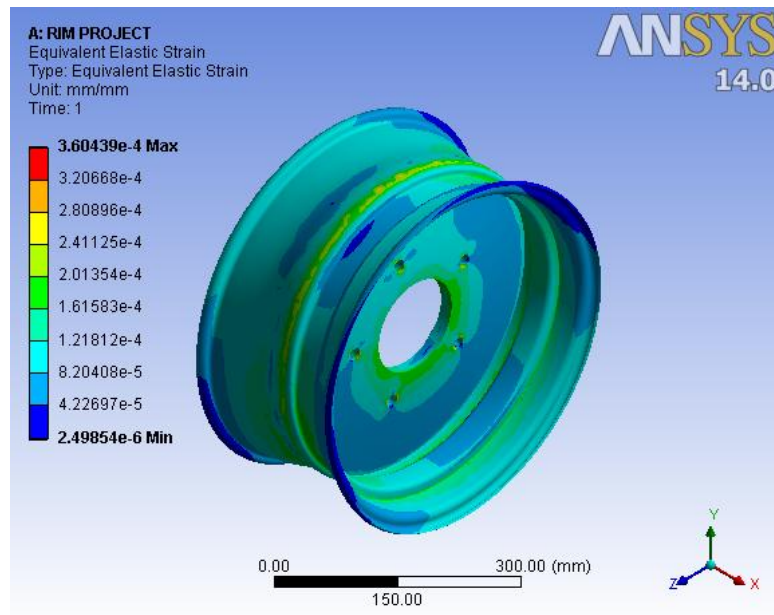

Fig. 12 Displacement plot at 275.79 kpa pressure 300 kg load

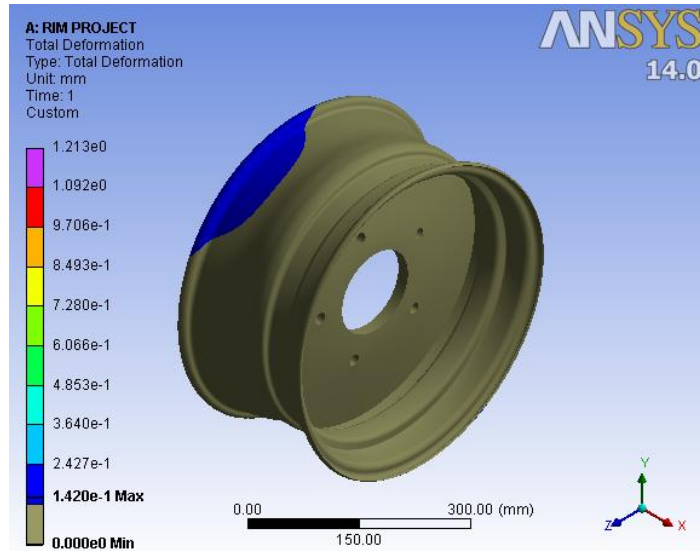

Fig.13. Total Deformation plot at 275.79 kpa pressure 300 kg load

III. Result

In Equivalent Elastic Strain in ansys results we get as in the practical conditions at different load condition also the wheel bends at the flange area at which it is connected with tire. It generally bends at the area of the centre plate of testing wheel rim which is also a very critical part of the wheel rim, in the below results table are shown that the maximum deformation at 150 kg, 225 kg and 300 kg radial load are as 0.3441, 0.3522 and 0.361 mm is occurred through the defined loading condition in the flange area. We studied the displacement and stress profiles of a testing wheel rim subjected to different load conditions namely; radial load (with inflation pressure) and axial load. We investigated the behavior of the rims for three different load conditions. We have comparison between experimental and numerical results of testing wheel rim we get at different load condition in experimental work having in z direction deflection values having higher in initial but after some time it will be decreases but in case of x direction deflection it has been increases at load condition has 150 kg, 225kg and 300 kg. The x direction deflection has been very less difference between numerical results getting from ansys software.

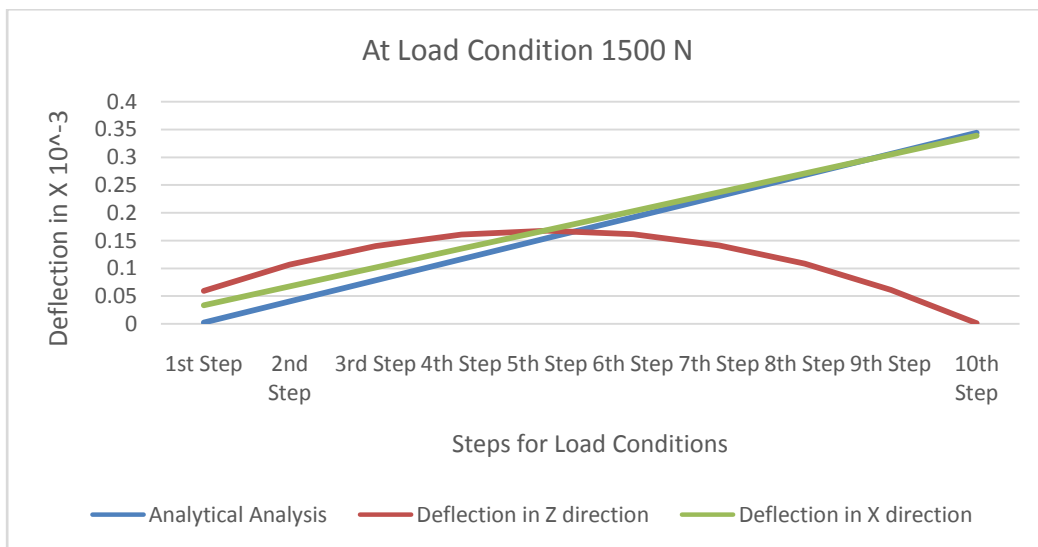

Fig. 14 - Result under various load steps at 1500N load

At the load condition 150 kg we found that the maximum deflection in numerical method has 0.3441 but in case of experimental method get in deflection in Z and X direction are 0.1678 and 0.3388. The deflection in X direction is very less difference through we get the deflection from numerical analysis.

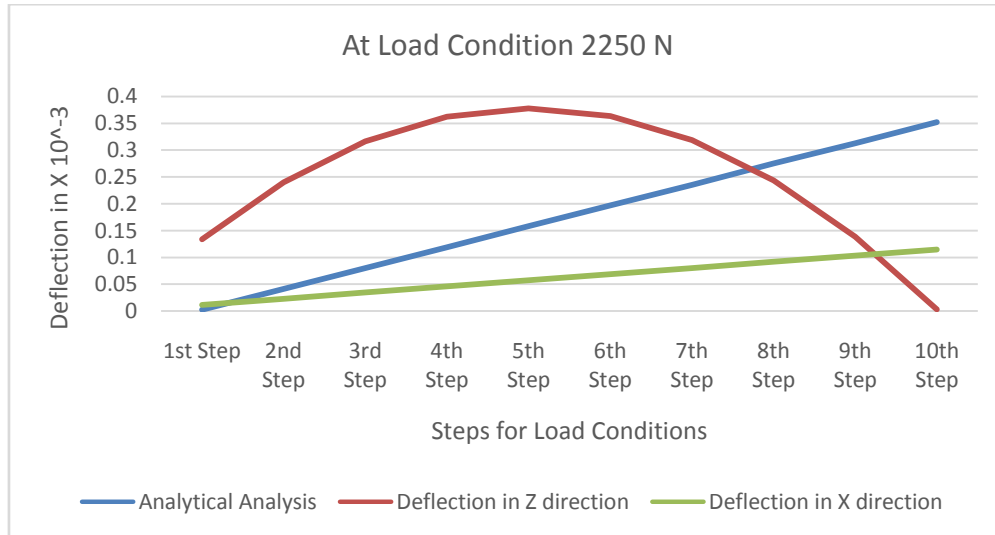

Fig. 15 - Result under various load steps at 2250N load

At the load condition 225 kg we found that the maximum deflection in numerical method has 0.3522 but in case of experimental method get in deflection in Z and X direction are 0.3776 and 0.1144. The deflection in X direction is very less difference through we get the deflection from numerical analysis.

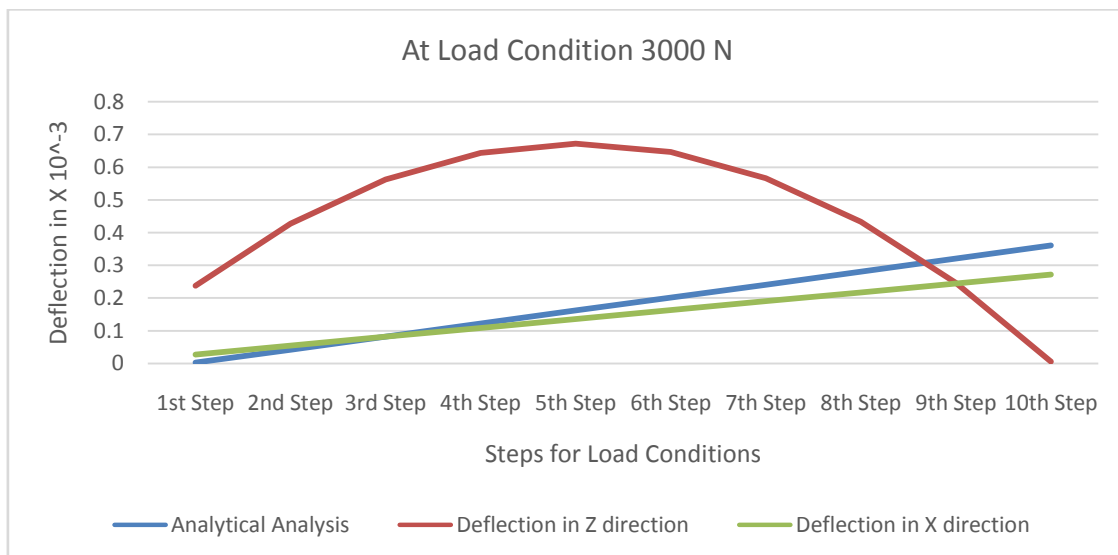

Fig. 16 - Result under various load steps at 3000N load

At the load condition 300 kg we found that the maximum deflection in numerical method has 0.361 but in case of experimental method get in deflection in Z and X direction are 0.0.6715 and 0.2714. The deflection in X direction is very less difference through we get the deflection from numerical analysis.

IV. Conclusion

The state of stress and mechanical response of automobile rims has been established, and therefore the effects of inflation pressure are currently well understood, additionally to the obligatory radial load. Analysis of gap pure mathematics and therefore the effects on the state of stress within the wheel is currently well outlined. Provided among are the observations of the consequences of environmental degradation rims has been documented, additionally to the established corrosion testing procedures that provided the reader a all-around background on the topic. The intensive literature search disclosed the necessity to additional investigate the impact of inflation pressure on the state of stress within the rim, and to produce a finite component analysis exploitation the additional correct brick element instead of the shell or plate element as in past publications. Experimental results were compared to finite component results. The contribution of this analysis wasn't to bench mark finite component stress analysis of the rim, this has been done by others within the references cited.

- The most contribution is 1) the experimental results and therefore the numerical methodology of the right strategies for applying the radial load,
 2) Comparisons of unambiguously known rim geometry's and therefore the effects of inflation pressure on the state of stress,
 3) Applying polynomial and series interpolations to actual tire rim nonlinear finite component model output information and exploitation the polynomials as input loading for the finite component model,
 4) Observations and documentation of environmental degradation in a very massive rim inventory of a neighbourhood check centre and,
 5) Crucial the impact of drilling a hole within the rim, and its impact on the state of stress at vital locations.

References

- [1]. Manivannan R, Rajasekar R, Gobinath VK 2018 Modelling and analysis of four wheel rim by using PEEK composites. *Material Science & Engineering International Journal*, Volume 2 Issue 6 – 2018.
- [2]. Jufu Jiang, Ying Wang, Gang Chen, Jun Liu, Yuanfa Li, ShoujingLuo 2012 Comparison of mechanical properties and microstructure of AZ91D alloy motorcycle wheels formed by die casting and double control forming. *Materials and Design* 40 (2012) 541–549, journal homepage: www.elsevier.com/locate/matdes, Received 8 February 2012 Accepted 13 April 2012, Available online 21 April 2012.
- [3]. M. Yaman, B.Yegin 2016 A Light Commercial Vehicle Wheel Design Optimization For Weight, Nvh And Durability Considerations 5th Ansa& µETA International Conference, 2016
- [4]. VajjaSai Ram, Ch Sridhar Yesaswi, E GopiManohar, B S N V N Sairam, N Anil Kumar 2017 ANALYSIS OF A FOUR WHEELER AUTOMOBILE RIM COATED WITH GRAPHENE NANO PARTICLES *International Journal of Pure and Applied Mathematics*, Volume 115 No. 6 2017, 17-23, ISSN: 1311-8080 (printed version); ISSN: 1314-3395 (on-line version), url: <http://www.ijpam.eu> , Special Issue
- [5]. G. Ragul , C. V Reddy, V. Jaya Kumar, Abhijit Roy, AbhishekSamanta, and C. Sreejith 2017 design, analysis and impact behaviour of magnesium alloys (zk60a) of low pressure die casting for automotive wheels by finite element method VOL. 12, NO. 22, NOVEMBER 2017, ISSN 1819-6608, ARPN Journal of Engineering and Applied Sciences ©2006-2017 Asian Research Publishing Network (ARPN). All rights reserved.
- [6]. Alexandruvalentinradulescu, sorincanana, irinaradulescu 2012 Mechanical testing methods concerning the stress analysis for a vehicle wheel rim *Mechanical Testing and Diagnosis*, ISSN 2247 – 9635, 2012 (II), Volume 2, 33-39.
- [7]. NagendraAkula , Dr K Rajagopal 2017 Experimental Investigation of Design and Fatigue Analysis of Two Wheeler Lighter Weight Compound Wheel IOSR Journal of Mechanical and Civil Engineering (IOSR-JMCE),e-ISSN: 2278-1684, p-ISSN : 2320–334X, PP 60-66, www.iosrjournals.org
- [8]. Saran Theja M, Shankar G, Vamsi Krishna M 2013 Design Analysis of Two Wheeler Lighter Weight Alloy Wheel RESEARCH • MECHANICAL ENGINEERING *Indian Journal of Engineering*, Volume 6, Number 15, November 2013, ISSN 2319 – 7757 EISSN 2319 –7765, published online 5 November; printed 30 November 2013.
- [9]. SenKai Lu, WenRu Wei, Liang Yu, Yanli Jiang, JunChuan Tan, HongQiang RU 2016 Fatigue Life Analysis of Aluminum HS6061-T6 Rims using finite element method.
- [10]. ChoudhuryDipeshRohan2015 Design and Analysis of a Composite Wheel Rim. *Journal of Material Science and Mechanical Engineering (JMSME)* Print ISSN : 2339-9095; Online ISSN : 2393-9109; Volume 2, Number 6; April – June, 2015 pp 50 – 56 KrishiSanskriti Publications <http://www.krishisanskriti.org/jmsme.html>
- [11]. Mr. SasankShekhar Panda*, Mr. Dibya Narayan Behera, Mr. Satya Narayan Tripathy 2016 MODELING AND STRUCTURAL ANALYSIS OF ALLOY WHEEL USING ANSYS [http:// www.ijerst.com](http://www.ijerst.com) © International Journal of Engineering Sciences & Research Technology, [Panda*, 5(3): March, 2016] ISSN: 2277-9655, I2OR), Publication Impact Factor: 3.785.
- [12]. D. Santhosh Kumar, Jayakumar V, ShajinMajeed 2017 Modal Analysis and Design Optimization of Automotive Wheel Rim Print ISSN: 0974-2115, www.jchps.com, *Journal of Chemical and Pharmaceutical Sciences*, January - March 2017 667 JCPS Volume 10 Issue 1.
- [13]. Daniel Antony C , Prince Jerome Christopher J 2016 Design and analysis of two wheeler alloy wheel rim using composite materials ISSN(Online) : 2319-8753, ISSN (Print) : 2347-6710, *International Journal of Innovative Research in Science, Engineering and Technology (An ISO 3297: 2007 Certified Organization)* Vol. 5, Issue 5, May 2016
- [14]. PratyushDeshmukh 2018 Topology optimization of wheel rim of heavy vehicle *International Journal of Current Advanced Research* ISSN: O: 2319-6475, ISSN: P: 2319-6505, Impact Factor: 6.614, Available Online at www.journalijcar.org, Volume 7; Issue 6(C); June 2018; Page No. 13289-13291.
- [15]. Vinay Kumar Pandey, Prof. AbhishekChoubey, Prof. Ashish Kumar Shrivastava 2016 A review on study of design and analysis of car wheel rim using fem *Scientific Journal of Impact Factor (SJIF): 4.14, e-ISSN (O): 2348-4470, p-ISSN (P): 2348-6406 International Journal of Advance Engineering and Research Development* Volume 3, Issue 4, April -2016
- [16]. V SathrudhanChoudhary, Jayaram MP, Farooq Abdulla V, Jefrindavis , Mohamed Akbar H , Rajasaminathan M 2016 Design and analysis of wheel rim with magnesium alloys (zk60a) by using solidworks and finite element method *novateur publications international journal of innovations in engineering research and technology [ijiert]* issn: 2394-3696, volume 3, issue5, may-2016
- [17]. G.Ashokkumar, M.UmaMahesh, S.MadhuSudhan, T.CHOLAI RAJ 2016 Design and analysis of wheel rim by using catia&ansys *International Research Journal of Engineering and Technology (IRJET)* e-ISSN: 2395 -0056, p-ISSN: 2395-0072 , Volume: 03 Issue: 12 | Dec -2016 , www.irjet.net.
- [18]. BimalBastin, Adars S, AkshayMadhu, Arun Krishnan, Betson Jose, Praveen Raj 2017 Finite Element Analysis of Wheel Rim Using Abaqus Software BimalBastin et al. *Int. Journal of Engineering Research and Application*, www.ijera.com ISSN : 2248-9622, Vol. 7, Issue 2, (Part -1) February 2017, pp.31-34
- [19]. E Chandrashekhar, Mr. J P Rishi 2015 Modelling and Analysis of Automotive Wheel Rim using FEM September 2015 | IJIRT | Volume 3 Issue 4 | ISSN: 2349-6002.
- [20]. Dr. Jamaleswara Kumar. P, Sai Krishna Narne, Aditya Talluri, Neeraj Yarra, Sri Ram. N 2017 Design and analysis of wheel rim with spoke patterns using different materials *International Journal of Mechanical Engineering and Technology (IJMET)*, Volume 8, Issue 5, May 2017, pp. 538–541 Article ID: IJMET_08_05_059, Available online at <http://www.iaeme.com/ijmet>.

Shubham V. Dongare. "Experimental and Numerical Analysis of Testing Wheel Rim." *IOSR Journal of Mechanical and Civil Engineering (IOSR-JMCE)* , vol. 16, no. 4, 2019, pp. 21-30