

Power Control in a Microgrid

Salisu Abdullahi¹, Naseer Ullah²

¹Electrical and Electronics Engineering, Yasar University, Izmir Turkey, ²Electrical and Electronics Engineering, Cecos University of IT and Emerging Science, Peshawar Pakistan
Corresponding Author: Salisu Abdullahi

Abstract: A micro-grid is a unifying of micro-sources together with a load and an optional energy storage device within a vicinity. The micro-grid can be operated in either autonomous, non-autonomous or a dual operation. In an autonomous operation micro-grid should generate its own energy and control it, as well. The components of the micro-grid which include 270kW of wind turbine, 40kW of micro-turbine, battery energy storage system with a capacity of 100kW and their control system have worked with each other in order to achieve power control in a micro-grid. The block diagram of the components and their parameters are made in a SIMULINK environment. The simulation test has been carried out by increasing the wind speed and decreasing the power demand in the system. Moreover, quick response of the battery energy storage system was observed in SIMULINK environment.

Keywords: Autonomous operation, control of power, Microgrid, Micro-Sources, Modelling and Simulation

Date of Submission: 10-09-2018

Date of acceptance: 03-10-2018

I. Introduction

A general μ G architecture is shown in Fig. 1. The μ G consist of three feeders namely; A, B and C. Combine heat and power (CHP) sources, non-CHP sources, loads, heat loads, two sensitive loads, one insensitive load and storage devices were connected on A and C, while and B carries only the loads. They have combined the two micro-sources and one storage device close to each other for minimizing the heat and power losses. Micro-sources are capable of supplying both power and heat to the loads. The micro-sources can be isolated or connected from the feeders by ON and OFF switches accordingly. Also the feeders A and C may be disconnected or connected to the μ G through circuit breakers (CB_1 - CB_2). The other feeder B is supplied with power only to the non-sensitive loads through an on/off circuit breakers. If the main grid has a problem or it is disconnected from μ G, the feeder B would not be able to supply power to its local loads. The μ G has been connected to the main grid through the point of common coupling (PCC) which acts as a circuit breaker (CB_4) [1]. If a problem occurs in the main grid, the μ G will be automatically disconnected from it through the PCC. The PCC may be used to connect or disconnect μ G from the main grid. In a grid connected mode, power could be transferred or received from the μ G through PCC. The CC has been controlling the entire energy sources and their local loads in the μ G. In island mode, the μ G should be able to generate its own energy and control it. A control techniques for distribution generation together with CHP in a μ G was presented in [2] by Robert H. Lasseter and Fellow, IEE Professor Emeritus. In [3], a Senior IEEE member Zhenhua Jiang described the control method of power sharing and voltage between parallel inverter-interfaced in an islanding operation by using drop control scheme. In [4], Rashad M AymenChaouachi and Ken Nagasaka studied different control strategies of transient dynamic response of two μ G close to each other. If the large disturbance was occurring in the main grid, the automatic gain control change the operation mode automatically. In [5], Rashad M. Kamel, AymenChaouachi and Ken Nagasaka analyzed the stability of μ G based on the import and export of active and reactive power from or to the main grid by control strategies of active and reactive power. In [6], Manohar Chamana and Stephen B. Bayne discussed another respond for changing the mode of operation between main grid and μ G through master slave control method. The control, coordination of changes in DG, load and structure in a μ G and power quality under different disturbance in the system was discussed by Li Bin, BaoHailong and Chenyao in [7]. In reference [8], Gelu Gurguiatu IonelVechiu and toaderMunteanu Presented a control function of active power conditional (APC) as an interface between renewable energy source and μ G for improving power quality through phase-lock loop (PLL).

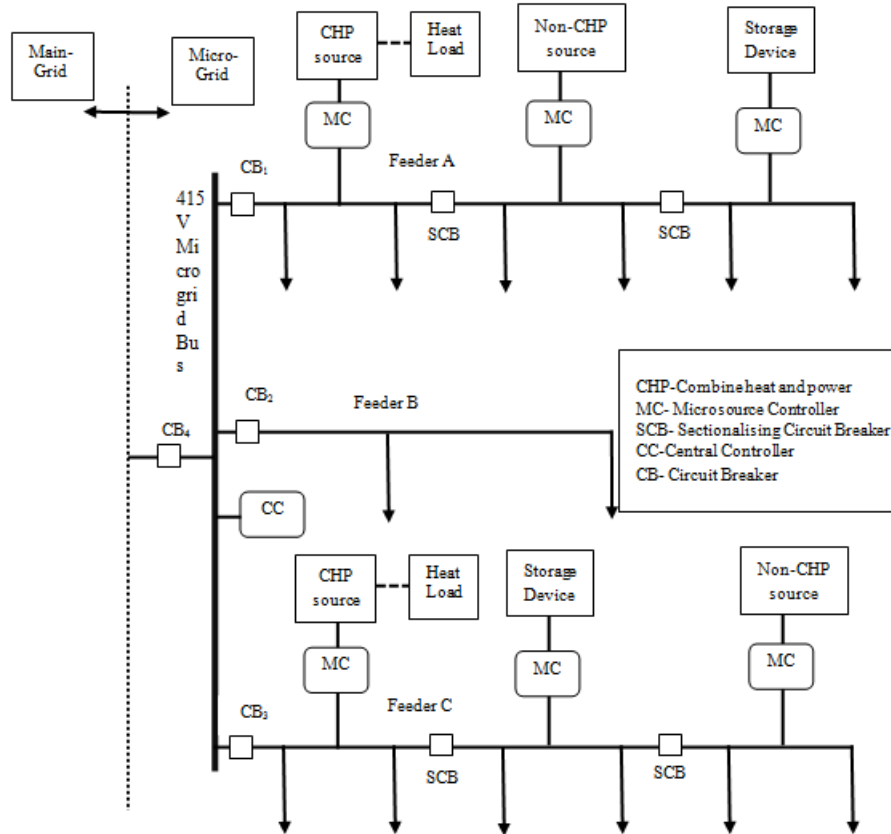

Fig 1. Typical Configuration of a μ G [1].

II. SIMULINK Model of the Micro-Grid

The overall SIMULINK model of the μ G is shown in Fig.3.1, where WTN, MTN, BTN and LDN are connection nodes of the wind-turbine, micro-turbine, battery and the load to the μ G. For simulation purposes two different loads are considered: when circuit-breaker BRK is open, load 1 is the only load, when BRK is closed, total load is the parallel connection of load 1 and load 2.

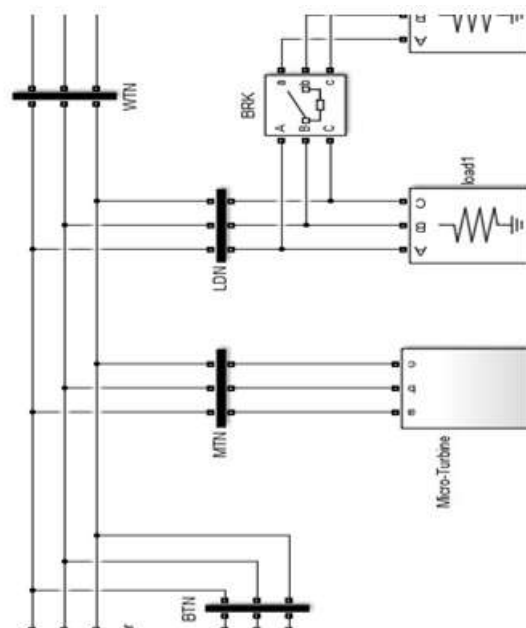

Fig 2. General Structure

III. Simulation Results

Case 1. The wind-speed changed from 11 m/s to 9 m/s at constant load and the following results were obtained. The first configuration, when battery and wind-turbine considered. The power from the wind-turbine decreased as a result of wind speed reduced and a battery compensates the power after 10s as shown in Fig 3.

In Fig 4, a voltage in a micro-grid reached the steady state after 13s. The second one, wind-turbine, micro-turbine and battery were working together. At 10s, the wind-speed dropped and power generated from the wind-turbine decreased. In Fig 5, both power from micro-turbine and battery recovered the power losses from wind-turbine. Micro-grid voltage attained the steady state after 12s, shown in Fig 6.

Case 2. At constant speed and change in loads from 250 to 350kW both power and voltage were observed. Initially, wind-turbine and battery arrangement was studied. In Fig 7, the battery compensated the increase in the power demand at 12s with steady state after 15s in micro-grid voltage, presented in Fig 8.

Lastly, all micro-sources and battery energy storage system were connected together. The load increased at 12s and both micro-turbine and battery balanced the power in the micro-grid, shown in Fig 9. In Fig 10, the voltage at micro-grid regained the steady state after 15.5s

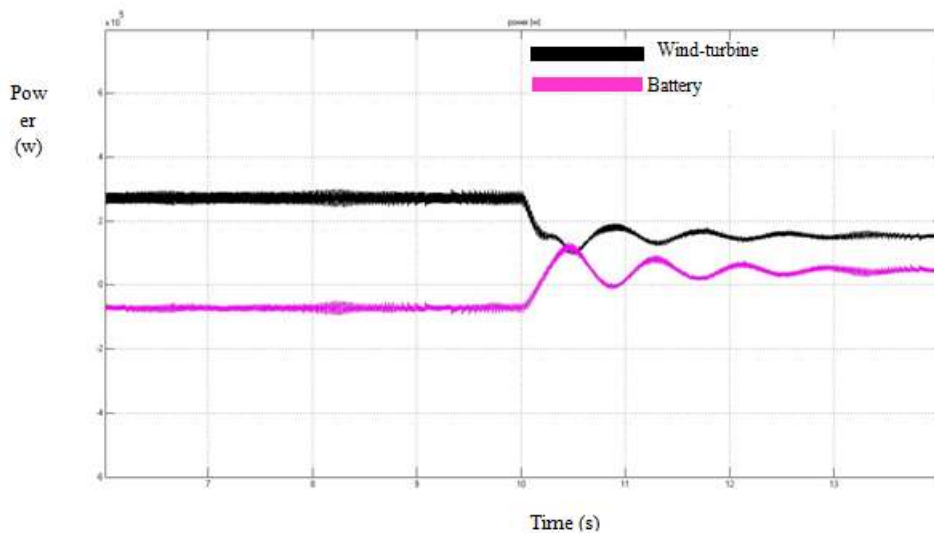

Fig 3. Power of μ G for WT and Battery with wind speed change.

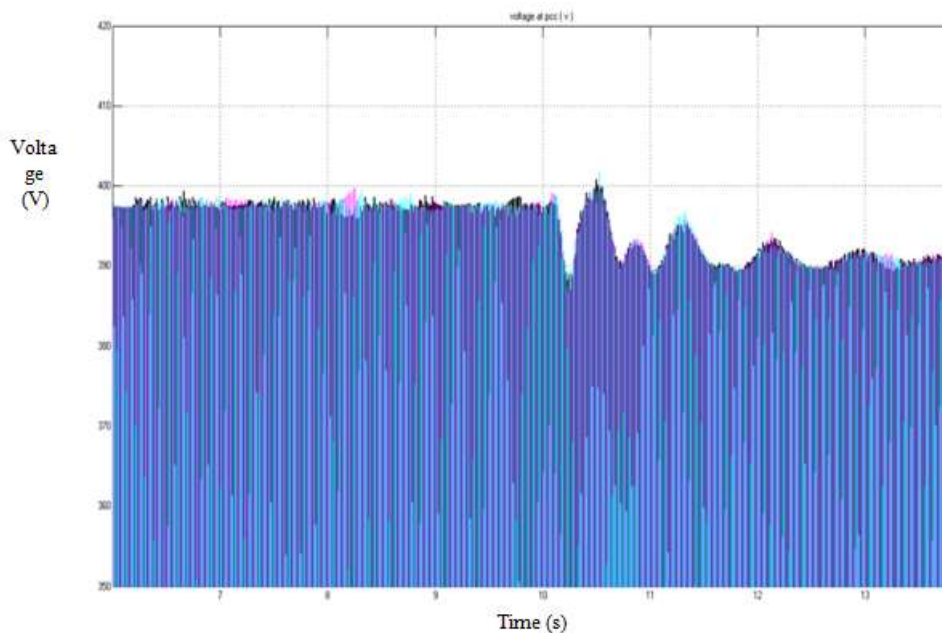

Fig 4. Voltage of μ G for WT and Battery with wind speed change

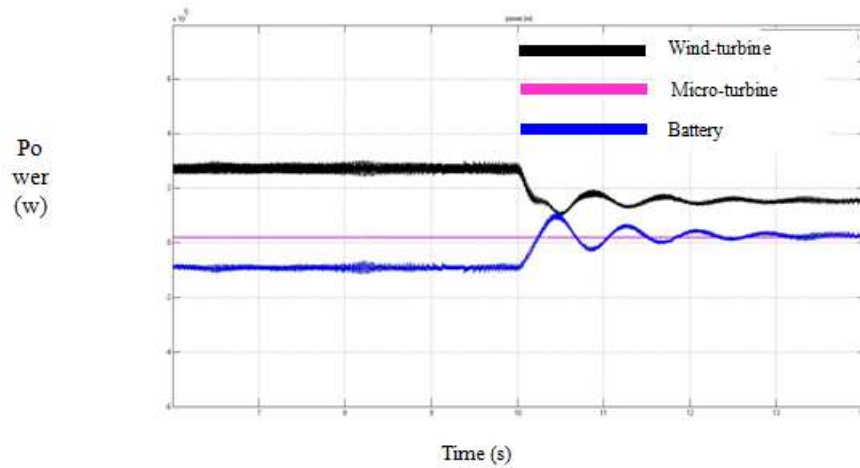

Fig 5. Power of μ G for WT, MT and Battery with wind speed change.

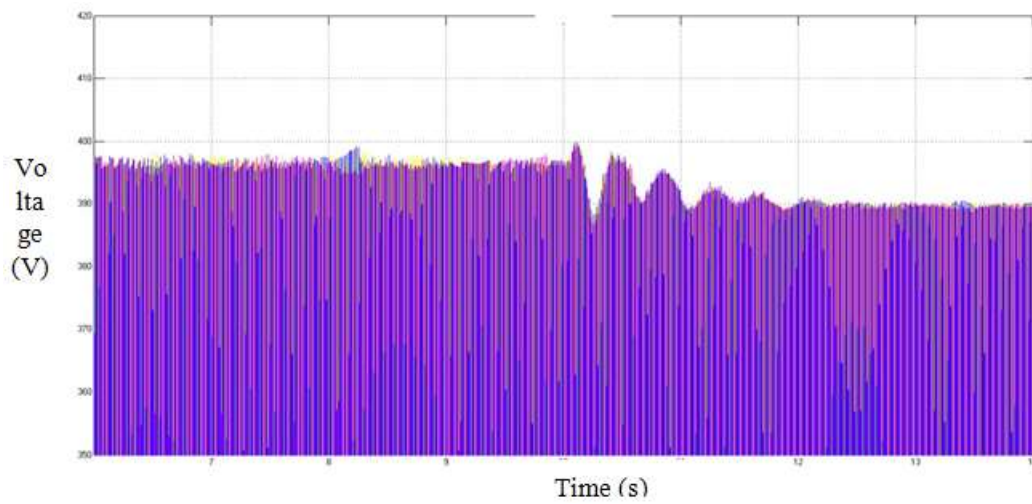

Fig 6. Voltage of μ G for WT, MT and Battery with wind speed change

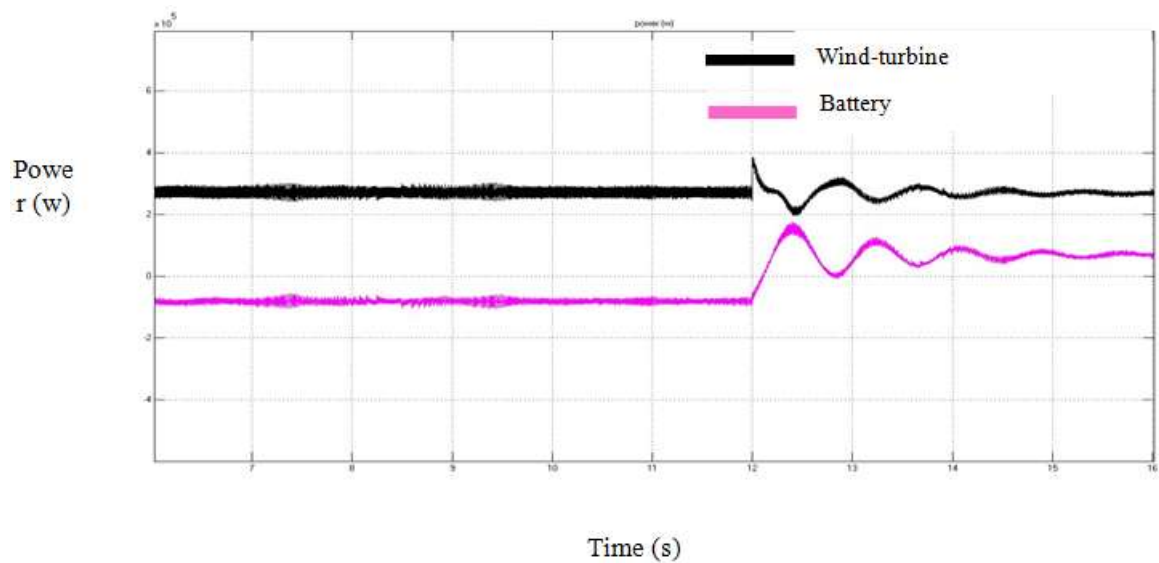

Fig 7. Power of μ G for WT and Battery with load change

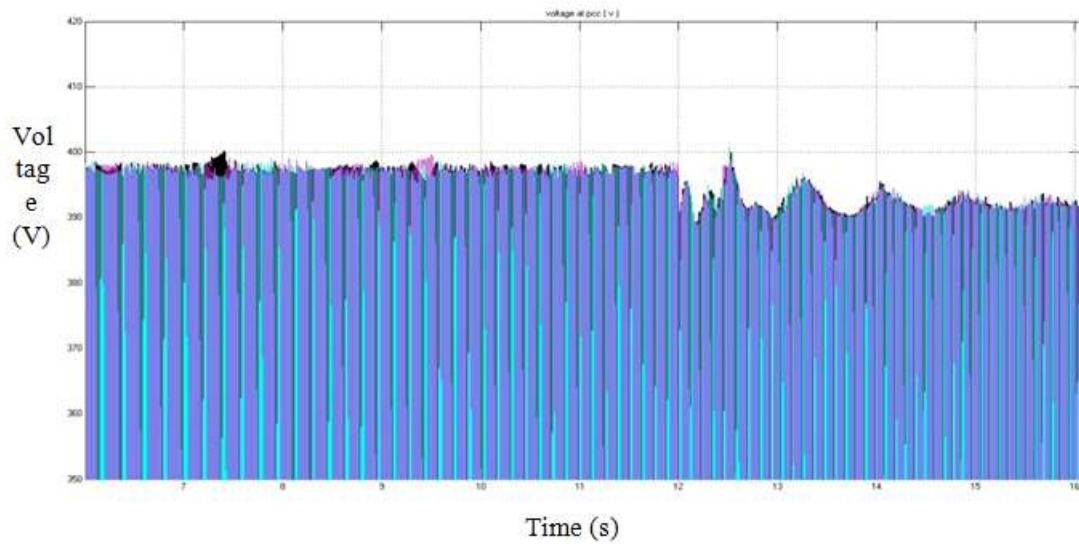

Fig 8. Voltage of μG for WT and Battery with load change

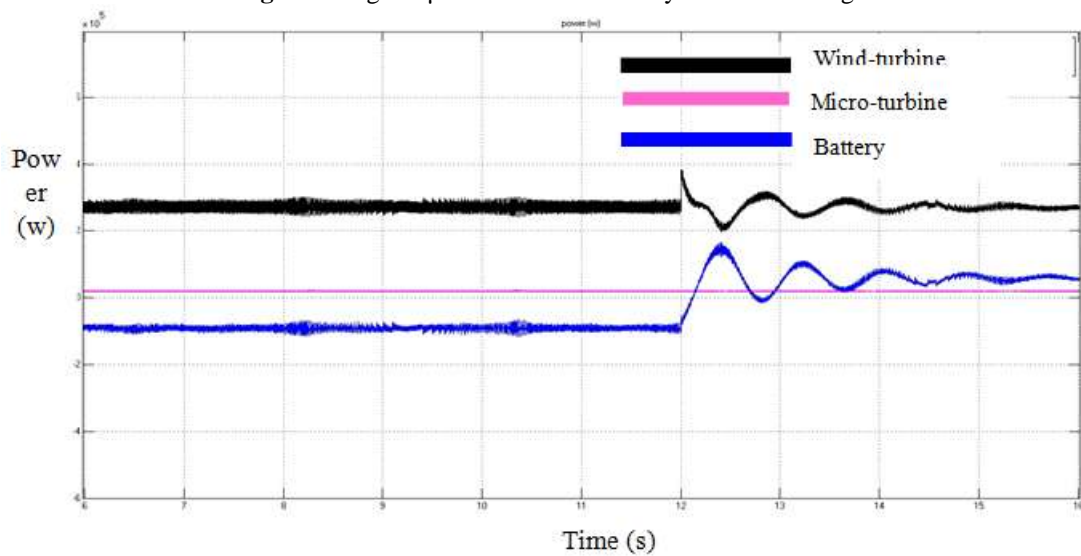

Fig 9. Power of μG for WT, MT and Battery with load change

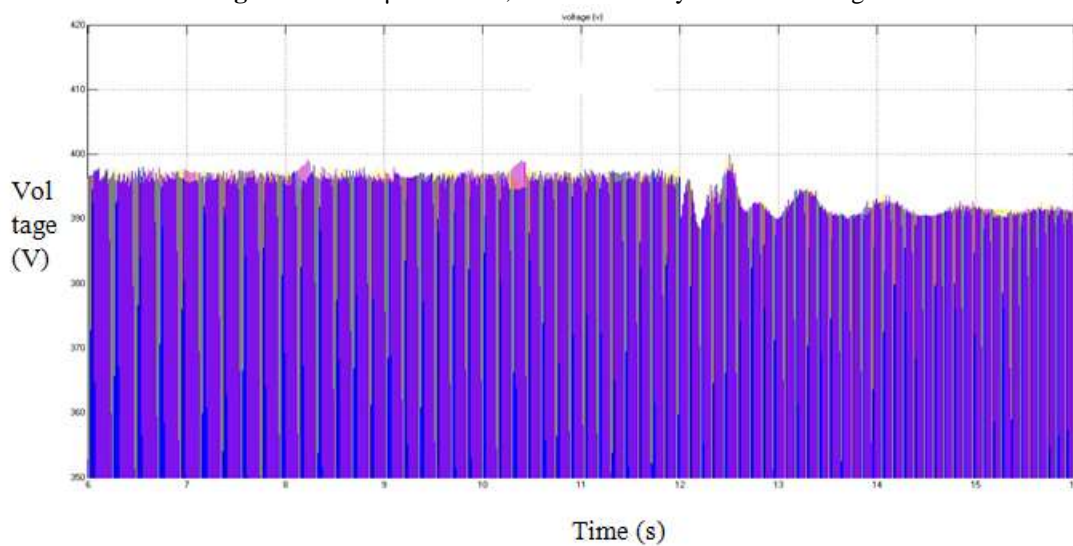

Fig 10. Voltage of μG for WT, MT and Battery with load change

IV. Conclusion

The research was conducted successfully with remarkable outcomes. The simulation result of the μ G model was obtained and the power control from different micro-sources in a μ G autonomous running has been analyzed. The battery energy storage system got recharge when the micro-sources power is more than the load power and after few seconds' changes has occurred either from wind speed or load and more power is not available in the μ G, battery discharged. The power control is capable of retaining any distraction in an autonomous μ G and supplies a pure power to the load. For any μ G to be manipulated in an acceptable way, one of μ sources must to be communicated with an energy storage device. Though some form of control and optimization was achieved. There is still issues with regard to the control of reference power for micro-turbine, which communicates with a battery through discharge and charge mode. This is potential direction for improvement upon this research work.

References

- [1]. S. C. a. P. C. S. Chowdhury, *Microgrid and Active Distribution Networks*, United Kingdom: The Institution of Engineering and Technology, 2009, pp. 4-7.
- [2]. R. P. P. Lasseter, «Microgrid: A Conceptual Solution.» %1 içinde PESC'04 Aachen, Germany, 20-25 June 2004.
- [3]. S. M. I. a. X. Y. Zhenhua Jiang, «Active Power - Voltage Control Scheme for Islanding Operation of Inverter-Interfaced Microgrids.» National Science Foundation, 2009.
- [4]. Rashad M. Kamel, Aymen Chaouachi, Ken Nagasaka, «Analysis of Transient Dynamic Response of Two Nearby.» scientific research, cilt 1, pp. 39-53, 10 December ,2010.
- [5]. Rashad M. Kamel, Aymen Chaouachi, Ken Nagasaka , «Detailed Analysis of Micro-Grid Stability during Islanding.» scientific research, cilt 3, no. 10.4236/eng.2011.35059, pp. 508-516, Received January 21, 2011; revised March 4, 2011; accepted April 6, 2011.
- [6]. Chamana, M. Bayne, S.B., «Modeling and control of directly connected and inverter interfaced sources in a microgrid.» %1 içinde IEEE, North American Power Symposium (NAPS), 2011, 4-6 Aug. 2011.
- [7]. Li, Bin Bao, Hailong ; Chen, Yao, «Simulation study on micro-grid coordinated control under islanding operation.» %1 içinde Power Electronics and Motion Control Conference (IPEMC), 2012 7th International , Harbin, China, 2-5 June 2012.
- [8]. Gelu GURGUIATU1 Ionel VECHIU2 and Toader MUNTEANU1, «google.» ESTIA-Recherche Bidart, [Çevrimiçi]. Available: <http://www.icrepq.com/icrepq%2711/437-gurguiatu.pdf>. [Erişildi: Friday April 2015].

Salisu Abdullahi.” Power Control in a Microgrid” IOSR Journal of Mechanical and Civil Engineering (IOSR-JMCE) , vol. 15, no. 5, 2018, pp. 16-21