

## **Investigation of Different Parameters of Air Cooler by CFD Analysis**

**Swanand Shrinivas Joshi**

*(M.E.Mechanical, JSPM's Rajarshi Shahu College of Engineering , Pune)*  
Corresponding author: Swanand Shrinivas Joshi

---

**Abstract**— Air cooler is appliance that keeping atmosphere cold in a very cost effective manner. The basic concept of water cooling is to find medium that can reduce the temperature of the environment cool. Water has a very good ability to retain heat, in the meantime stay in liquid form. In this case, there is study about various air cooler models and select one of the model that is better and cost effective. The psychometric principles studied and compare the efficiency of the air cooler at various humidity conditions. Then we study about the evaporation rate of the water of specific quantity with different air velocity. The comparison analysis of air cooler with water and without water and how much effectiveness it is providing based on experimental studies.

**Index Terms** – Air cooler, Cooling pad, Mass flow rate, Humidity

---

Date of Submission: 15-06-2018

Date of acceptance: 03-07-2018

---

### **I. Introduction**

India is a tropical country in which most of the regions experience very low temperatures during the winter and very high temperatures during the summer seasons. That is, the temperature range between summer and winter seasons is very large. Hence, it is not a very pleasant experience and highly uncomfortable. Though cheaper methods of heating are available during the winter season, methods of cooling down the hot temperatures during the summer do not have wide variety of options. Air conditioners have high initial and running costs, which cannot be afforded by all the people in a developing country like India. Air coolers are relatively cheap, but provide unsatisfactory results; there is a need for developing a cheaper room cooling system. Conventional air conditioning is one of the major contributors of CFCs into the atmosphere. An alternative type of cooling, which does not expel CFCs is highly desirable as one important step in the correction of this problem. So, this is why adiabatic cooling is environmentally friendly because it is a passive cooling method that does not expel CFCs. It is 100% fresh air-cooling which even helps to clean the air it cools. With the help of Evaporative Technology swamp coolers provide cooling at cheaper than central air or larger air conditioners. A Regenerative type evaporative cooler cools air using a heat exchanger in addition to the direct evaporative method of cooling. It is observed that the overall efficiency of the system and the COP increase by about 20-25% than the normal air cooler system but the initial and maintenance costs of the system are increased due to the addition of a heat exchanger and a pump. The size of the system also increases due to the addition of more components. A multi- utility desert cooler is one in which water cooling as well as cold storage systems are attached in addition to the air cooling system. The average effectiveness was found to be 65.42% and a temperature range of 22-27o C was achieved. It can be used only in areas with high temperature and low relative humidity hence reducing its scope. Ndukwu MacManus Chinenye developed a clay evaporative cooler for the purpose of preservation of fruits and vegetables at a lower temperature and also to study the physical parameters such as cooling efficiency, cooling capacity, etc. in the system. The results showed that the evaporative cooler reduces the temperature up to 10o C and increases the relative humidity of incoming air for the storage chamber. The evaporative cooler was able to preserve freshly harvested tomatoes for about 19 days. It is observed that clay is a material which helps in evaporative cooling and has shown proven results and hence can be used as a vital element in the air cooling system. Hence, it is proposed to build an air cooler which provides better room cooling in addition to providing a cold storage box.

### **II. Problem statement**

The air cooler is a cheaper technology compares to air conditioner in terms of energy efficiency and total cost. The study of air cooler efficiency and effectiveness based on the humidity is necessary because its feasibility in high humid regions have to be investigated. The other fact is the rate of water consumption in the air cooler if it is goes beyond the expected limit it will be problem for the drought ridden parts of the country.

**Need of the project**

The air cooler is one of the appliances used across India and the total sales is in crores of rupees and the efficiency and effectiveness of the system need to identify to increase the performance and efficiency of the system. If the air cooler system is proven very effective in this study then we can suggest people to choose air cooler due to its cost effectiveness.

**Objective of the project**

- To study about various comparison parameters between air conditioners and air coolers
- To analyze the air cooler in terms of efficiency and performance.
- To compare the air cooler in geographic basis and investigate the efficiency difference
- To compare the air cooler with a fan and air conditioner based on efficiency and performance

**Working Principle**

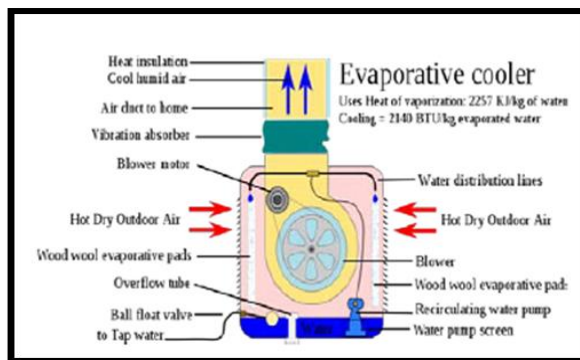

Fig. 1 Working Principle

An evaporative cooler is essentially a large fan with water moistened pads in front of it. Fan draws warm outside air through the pads and blows the now-cooled air throughout the house. Pads can be made of wood shavings. Aspen tree wood is traditional choice. They are also called as excelsior, need to be replaced every season or two, and generally cost \$20 to \$40 for a set. Small distribution lines supply water to top of pad. Water is soaked by pads and due to gravity, trickles through them to collect in a sump at the bottom of the cooler. A small re-circulating water pump sends the collected water back to the top of the pads

A large fan draws air through the pads, where evaporation drops the temperature approximately 20 degrees. The fan then blows this cooled air into the house. Small units can be installed in a window,

Blowing cooled air directly into room.

**Component of project**

**Cooling Pad**

Most of the cooling pads are made up of Aspen fiber or cellulose. A cellulose pad typically needs more air and water flow than Aspen material. More evaporation can take place through a 6-inch pad than a 4-inch pad. A temperature reduction of 10 to 20 degree Celsius (50-68 degree F) can be achieved by passing hot fresh air through wetted pads.

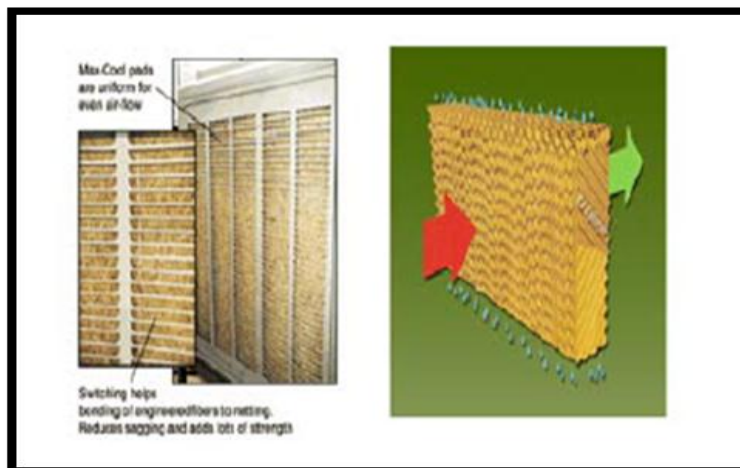

Fig. 2 Cooling Pad

**Blower motor**

Forced air is passed through heating or cooling elements and circulated to desired location. Air movement is provided by blower motor. Blower motor is combination of electric motor and fan. Generally a centrifugal fan with 6- to 10-inch hamster cage is used.



**Fig. 3** Blower motor

**Blower Fan**

System of air cooling in cooler most commonly rely on forced air. Forced air is passed through cooling elements circulated to desired locations.



**Fig. 4** Blower Fan

Fan efficiency is ratio between the power transferred to air stream and power delivered by motor to fan. The power of air flow is product of pressure and flow, corrected for unit consistency.

**Re-circulating water pump**

A recirculating pump draws water from the basin under pumps it through a system of sprays(or water distributors) from which water is directed onto the tube surfaces. Air is induced or forced over the wetted tube surfaces and through rain of water droplets. Evaporation is used to increase the rate of heat transfer from the tubes to the air.



**Fig. 11** Re-circulating water pump

**Computational fluid dynamics (CFD)** is a branch of fluid mechanics that uses numerical analysis and data structures to solve and analyze problems that involve fluid flows. Computers are used to perform the calculations required to simulate the interaction of liquids and gases with surfaces defined by boundary conditions. Ongoing research yields software that improves the accuracy and speed of complex simulation scenarios such as transonic or turbulent flows. Initial experimental validation of such software is performed using a wind tunnel with the final validation coming in full-scale testing, e.g. flight tests.

**1 Room with cooler and vents**

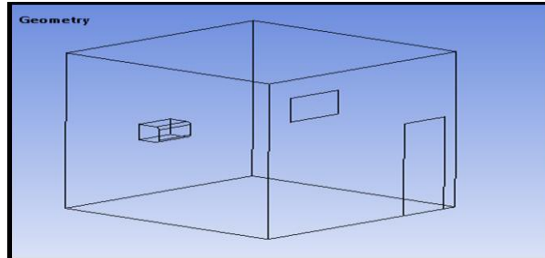

**2.Mesh**

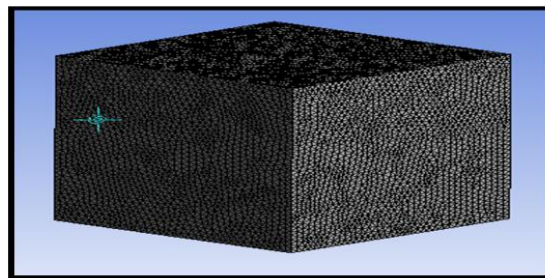

Statistics	
<input type="checkbox"/> Nodes	42462
<input type="checkbox"/> Elements	221951

**3. Named Selection**

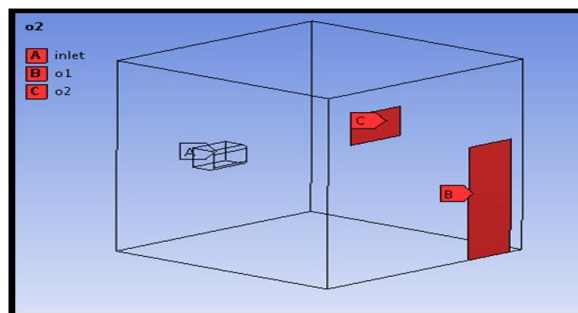

**4. Mass flow rate 1kg/s**

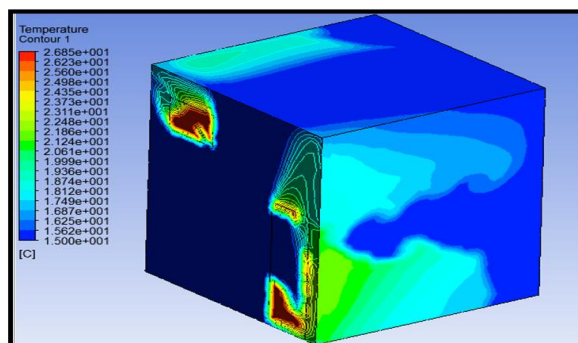

5. Volume rendering

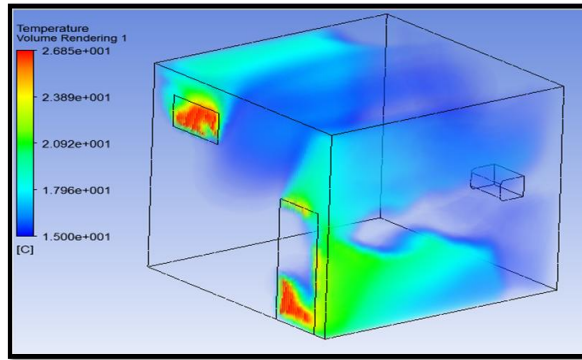

6. Velocity

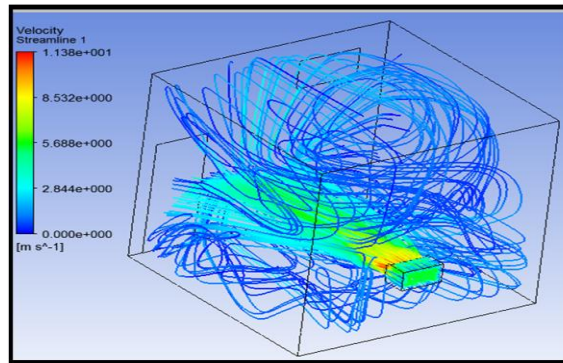

7. Mass flow rate 0.5 kg/s

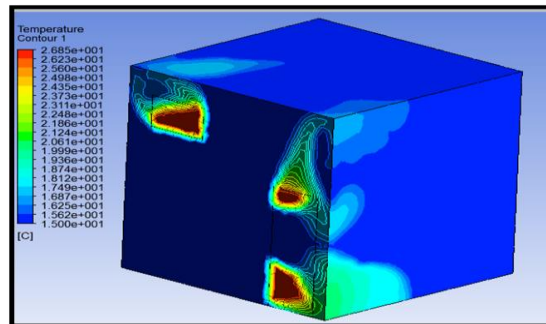

Temperature  
8. Volume rendering

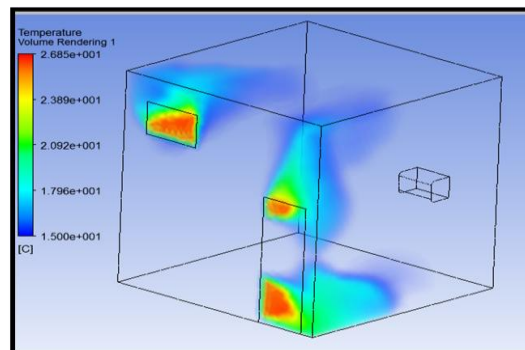

9. VENT TEMPERATURE 40 DEG

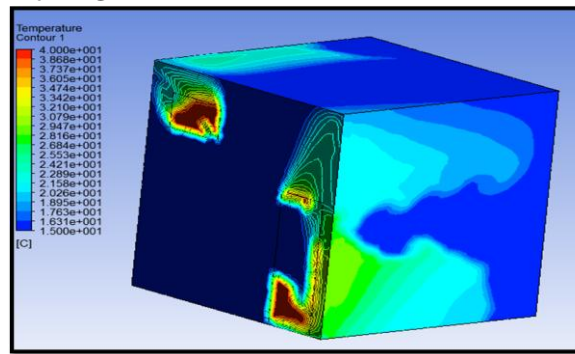

Temperature

10. Volume rendering

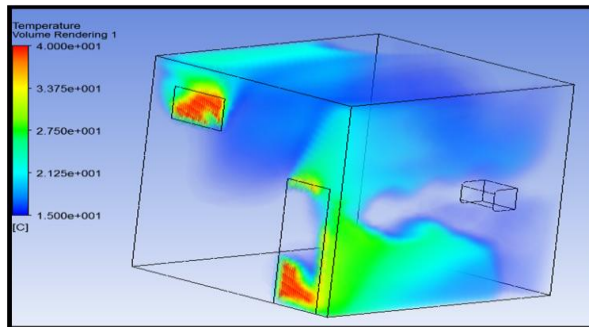

11. Velocity

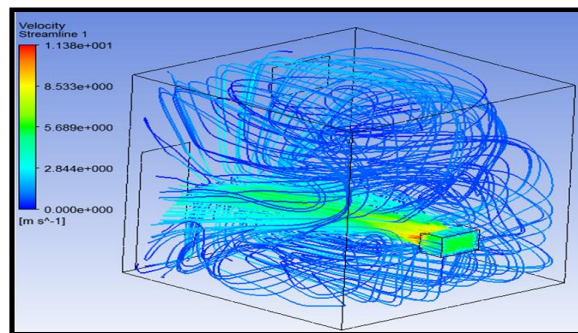

12. VENT TEMPERATURE 50 DEG

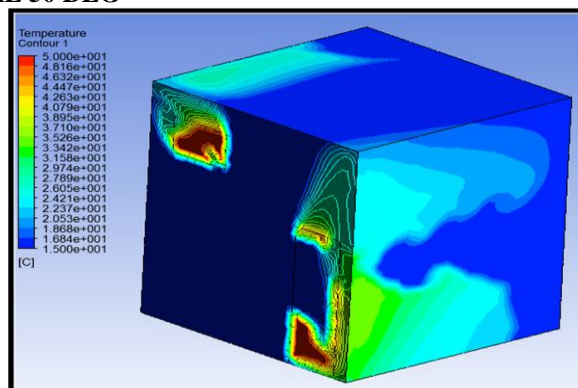

## Temperature

### 13. Volume rendering

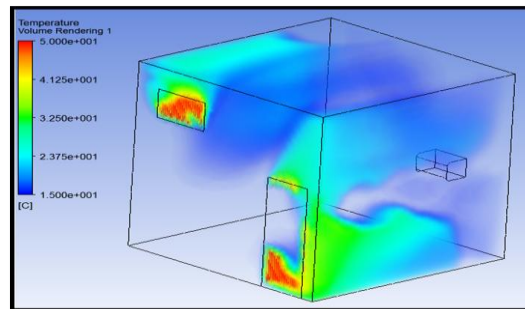

### 14. Velocity

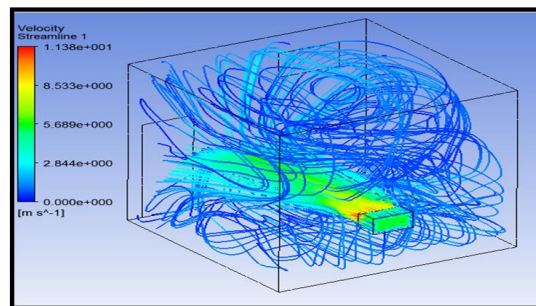

## III. Conclusion

With the ongoing energy crisis and pollutant emission constrains, use of evaporative air coolers are much advantages.

The difference between the outside air dry bulb temperature and the wet bulb temperature is the key factor which decides the use of evaporative coolers. Larger the difference, usefulness of evaporative coolers is better.

Cabinet type coolers are sufficient for cooling of small air volumes. For large spaces, more cabinet coolers are employed

From CFD analysis we selected accurate effective blade of Air cooler

## Reference

- [1]. Application of Evaporative Cooling Concept to Save Energy while improving the indoor Environment, Brown. W. K, ASHRAE Transaction 97 pt2, 2013.
- [2]. "Development and Testing of Regenerative Evaporative Cooler", J.K.Jain and Hindoliya D.A, International Journal of Engineering Trends and Technology, Vol.3, No. 6, Pp 694-697,2012.
- [3]. "Design and Development of Energy Efficient Multi-Utility Desert Cooler", M.P.Poonia, A.Bhardwaj, Upender Pandel and A.S.Jethoo A.S, Universal Journal of Environmental Research and Technology, Vol. 1 Pp 39-44, 2011.
- [4]. "Modified Desert Cooler", B.Chandrakant, Kothare and NitinB.Borkar, International Journal of Engineering and Technology, Vol.3, No.2, Pp 166-172, 2011.
- [5]. "Development of Clay Evaporative Cooler for Fruits and Vegetables Preservation", Ndukwu Macmanus Chinenye, AgriculturalEngineering International: CIGR Journal Manuscript No.1781. Vol. 13, No.1, Pp 1-8, 2011.
- [6]. "Improving the environmental cooling for air-coolers by using the indirect-cooling method", Farhan A. Khmamas, ARPN Journal of Engineering and Applied Sciences, Vol. 5, No. 2, Pp 66-73, 2010.
- [7]. "Comparative performance of evaporative cooling pads of alternative materials", R.K.Kulkarni and S.P.S.Rajput, International Journal of Advanced Engineering Sciences and Technologies, Vol.10, No. 2, Pp 239-244, 2011.
- [8]. "Improvement of Evaporative Cooling System Efficiency in Greenhouses" Sirelkhatim K. Abbouda and Emad A. Almuhanha, International Journal of Latest Trends in Agriculture & Food Sciences, Vol. 2, No. 2, Pp 83- 89, 2012.
- [9]. "Optimum Design of Evaporative Air Cooler", Hussain Yousif Mohammed and Abduljaleel Hussain Abd, Journal of Kerbala University, Vol. 10, No.2, Pp 287-299, 2011

Swanand Shrinivas Joshi "Investigation of Different Parameters of Air Cooler by CFD Analysis." IOSR Journal of Mechanical and Civil Engineering (IOSR-JMCE) , vol. 15, no. 3, 2018, pp. 95-101.