

Hydraulic System for Motor Cycle – A Review

Prof. Dr. R. Subburaj

Research Analyst

Abstract: In Hydraulic Power System, pressurized fluid is supplied by a pump driven by an electrical motor. Hydraulic Brake is an association of braking mechanism which makes use of brake fluid, commonly containing ethylene glycol, to switch pressure from the controlling unit, which is usually close to the operator of the vehicle, to the rear brake mechanism, which is typically at or near the wheel of the vehicle. This paper presents the design of the hydraulic system for motorcycle and analyzes the utility of different brake circuits used.

Keywords: Hydraulic valves, Brake pedal, Anti-Braking System.

I. Introduction

A hydraulic braking system transmits brake-pedal force to the wheel brakes through a pressurized fluid, converting the fluid pressure into useful work of braking at the wheel. Motorcycle brake structures are in a constant state of technical development [1]. The driving force behind this improvement is the end consumer's desire for continuous improvements in comfort, riding pleasure and protection. Increasing comfort means, on the one hand, development of brake systems in which moderate corrections in speed can be done by applying minor forces to the hand brake lever. Here, the hand lever feeling ought to correspond with the feeling of deceleration and should reflect the deceleration performance. Moreover, comfort is also increased by additional features that can be realized with the brake system or in connection with other motorcycle systems. These consist of, as an instance, brake systems that effectively prevent rolling back when beginning on inclines, or permit comfortable starting on inclines without the need for the rider to balance the motorcycle with the throttle and brake. Riding pleasure with regard to the primary brake system approach has a direct response of the brake with a characteristic for the hand brake lever braking effect and deceleration that is adapted to the motorcycle characteristics. The rider expects a direct reaction of the motorcycle to his wish to break. Besides this, additional functions can also increase riding pleasure. These include features that increase comfort, as well as features that reduce the number of actuating factors required to achieve a braking effect corresponding to the riding situation. This paper presents the various hydraulic braking systems for motor cycle.

II. Hydraulic Brake Systems

The principles of motorcycle brake systems can also be understood as describing the evolution of these systems. A hydraulic braking system transmits brake-pedal force to the wheel brakes through pressurized fluid, converting the fluid pressure into useful paintings of braking at the wheels. The brake pedal relays the driver's foot attempt to the master-cylinder piston, which compresses the brake fluid. This fluid stress is equally transmitted at some point of the fluid to the front disc-caliper pistons and to the rear wheel-cylinder pistons. This provision additionally permits the driver to stop the vehicle in the event of failure of the hydraulic brake system [1]. In a 2-circuit brake system shown in Figure 1, in which the rider creates hydraulic pressure. For example by depressing a hand brake lever, this is transferred to the front wheel brake through hydraulic lines, and is then converted into braking force applied to the wheel. This process also applies to actuation of the foot brake lever (or second hand brake lever). Nowadays, disk brakes are mostly used in brake systems. Such brake systems are technically deceptive and are employed in a different ways, but without additional measures they do not stay up to the necessities placed on modern brake systems for motorcycles in order to avoid wheel lockup. The rider must self modulate the pressure in the brake system so one can attain a quick braking distance. This manner that build up of braking pressure on the front wheel need to be as quick as viable according with the ideal braking pressure distribution, without causing the wheel to lock up. At the same time, braking pressure have to additionally be constructed up as fast as possible on the rear wheel, but must also be reduced again during braking due to the dynamic shift in the centre of gravity.

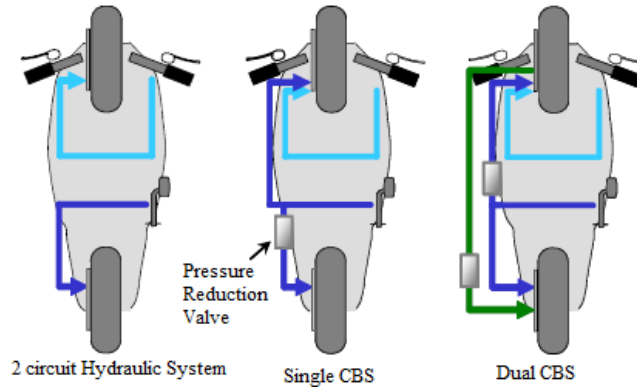

Figure 1: Principles of Hydraulic Brake System

III. Hydraulic Abs Brake Systems

In the past few decades, many styles of anti-lock braking systems (ABS) were mounted in specific varieties of vehicles, but no longer in light-weight bikes, used frequently in big towns [2-5]. When riders of motorcycles without ABS carry out emergency braking maneuvers, they're frequently thrown off the automobile. This is in particular apparent in wet conditions. As an end result, non-ABS mild bikes purpose many casualties. Most of the ABS installed upon four-wheel vehicles adopts an additional hydraulic pump and valves to modify the braking strain. But each length and price constraints prevent their installation on light bikes [6]. The new braking system approaches the pace of the contact of the motorbike tire with the ground relative to the speed of the motorbike and calculates the quantity of tire slippage coefficient at the ground at the time of braking; minimizing it as a lot as viable ensuing in a boom within the controllability of the motorcycle. Preventing wheel lockup and accordingly maintaining stability can be ensured only by a system that actively modulates the brake pressure, i.e. a system which reduces the braking pressure in certain situations, thereby maintaining lateral stability. The new ABS hydraulic circuit is shown in Figure 2.

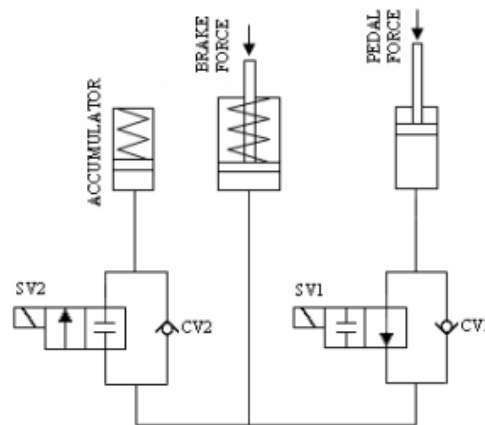

Figure.2The diagram of motorcycle new ABS hydraulic circuit

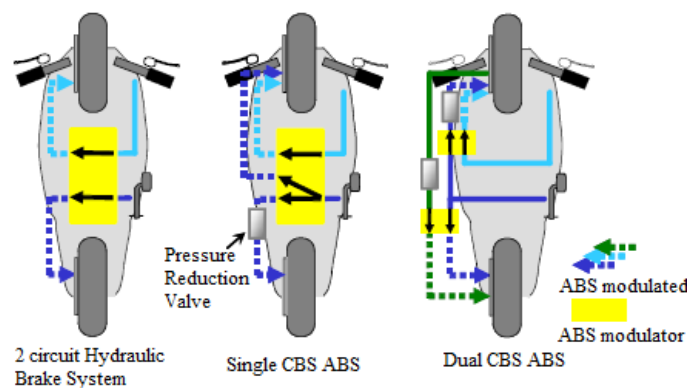

Figure 3. Principles of ABS Brake Systems.

The principles of ABS braking system is shown in Figure 3. When the electric motor is started and the flywheel reaches the desired speed, a controllable load is exerted at the flywheel by the motorcycle tire which is a completely close to the imitation of the motorbike weight and its riders. Then, by switching the electrical motor off i.e, the launch of the accelerator of the bike even as braking, the method of braking begins. Without the brakes being locked, the motor stops inside a shorter time and distance compared to while the ABS system is not energetic. The motive is the designed system keeps the tire within the threshold of slippage relative to the ground and the brake force with its maximum strength reduces the stoppage time. Because value is one of the constraining and affecting elements for its use and development, in the design of the new device, financial constraints are taken into consideration in a way that the mass manufacturing of this product and its installation on traditional motorcycles is reasonable.

The precept is similar to a single CBS-AB device, except that there's an extra modulator circuit on the front wheel because of the relationship of the rear wheel control. Such systems require a total of 3 manage channels which may be regulated independently of each other. Dual CBS-ABS is characterized via the reality that the dual CBS brake machine noted above is supplemented through ABS modulators. Here, a total of four manage channels is needed. One channel is required in each case for regulating the braking strain from the hand lever to the front wheel, from the foot brake to the front wheel and to rear wheel, and from the secondary cylinder on the front wheel to the rear wheel.

IV. Electro-Hydraulic Integral Brake Systems

Electro hydraulic brake structures are the combination of electronics and hydraulics to create a greater flexible brake system is shown in Figure 4. The electronics provide control flexibility, even as the hydraulics delivers the power. Electro-hydraulic braking offers many advantages over traditional hydraulic braking systems. These advantages may be exploited to offer improved machine overall performance and greater consolation for the operator.

However, systems are regarded from the automotive sector this is capable of constructing up pressure at the individual wheels actively. Such structures are used for Electronic Stability Control (ESC). This principle is applied for motorcycles in developing electronic integral brake systems. Like single CBS systems, the devices can to begin with be structures that build up pressure on the front wheel brake while the rider actuates the foot control lever. This is a partial fundamental brake system which acts in forwarding route. Analogously, a partial integral device acting to the rear also can be implemented, in which pressure is carried out to the rear wheel thru an electrically controlled pump every time the handbrake lever is actuated.

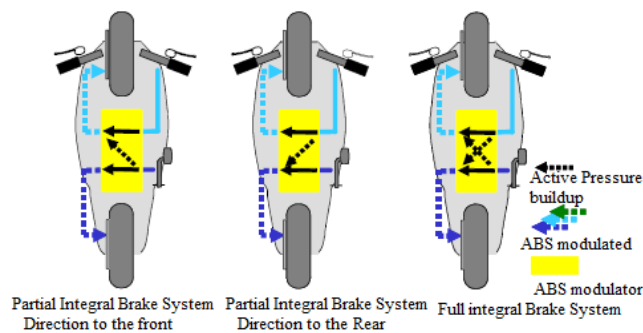

Figure 4.Principles of Electronic Integral Brake Systems.

Motorcycle Anti-lock Brake System (MAB) System Diagram with ECU is shown in Figure 5.

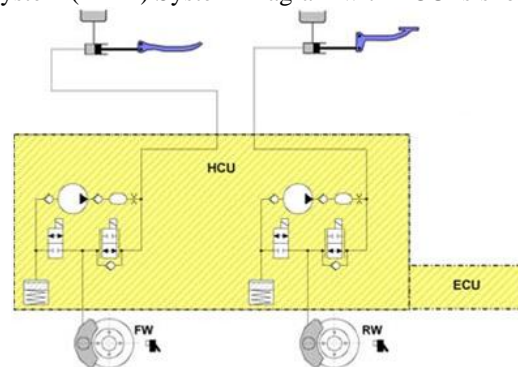

Figure 5. Motorcycle Anti-lock Brake System (MAB) System Diagram.

V. Mib Mk 1-3 Partial Integral Brake System

The full Motorcycle Integral Brake System (MIB) is the most superior tool for motorcycle packages and offers the possibility of actively constructing up the strain on both the front and rear wheel via performing on a single brake command [7]. In addition to the capability of a pure ABS system, an integral brake system can actively build up braking stress at the wheels without the rider having to perform the corresponding controls (Figure 6). A partial critical brake system is composed of a total of 6 hydraulic valves, for the front wheel circuit, four for the rear wheel circuit, three pressure sensors, one low strain accumulator and one hydraulic pump per wheel circuit and an ECU (Electronic Control Unit). The pumps of each wheel circuit are both driven by means of an electric motor. If the rider actuates the handbrake lever, the stress is hydraulically implemented to the front wheel brake. At the identical time, the strain sensor measures the pressure boom and sends this record to the ECU. The pump motor is controlled according to with present traits, working modes or different function variables. To actively building up pressure on the rear wheel, the reduce valve (TV-HR) is closed and the suction valve (EUV-HR) is opened. Then the pump sucks brake fluid out of the reservoir and builds up pressure in the rear brake caliper.

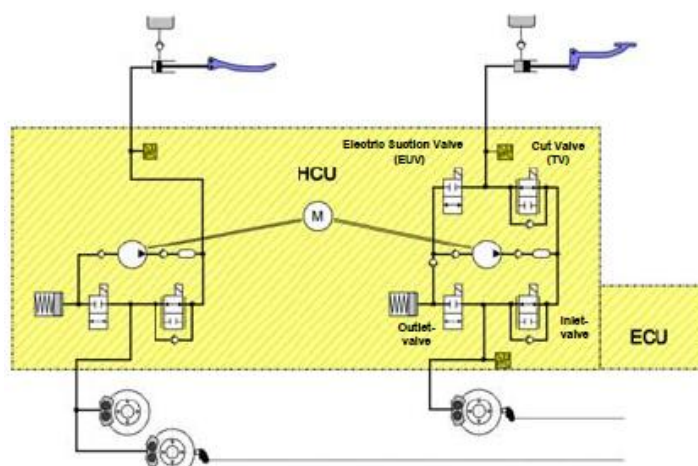

Figure 6. Motorcycle Integral Brake System (MIB) Partial Integral Brake Function.

If the rider additionally turns on the foot brake lever, the suction valve is closed over again the wheel braking stress is attained, and the cut valve is reopened, in order that the rider has direct intervention from the foot pedal to the rear wheel brake once more. The transitions represent a particular task on this admires. The goal is to layout the transitions in the sort of manner that the rider hardly perceives any remarks in the foot lever. This is possible with a balanced design of the hydraulics and the control software.

VI. Mib Mk 1-4 Full Integral Brake System

In addition to the functionality of the partial integral brake system, the entire vital brake machine also offers the opportunity of actively constructing up strain at the front wheel [7]. This is realized by using an additional solenoid. The functionality is just like that of the integral brake system, except that moreover the rider enter is also measured on the rear wheel control. Braking pressure also can be built up on the front wheel corresponding to the using situations and desired characteristic is shown in Figure 7.

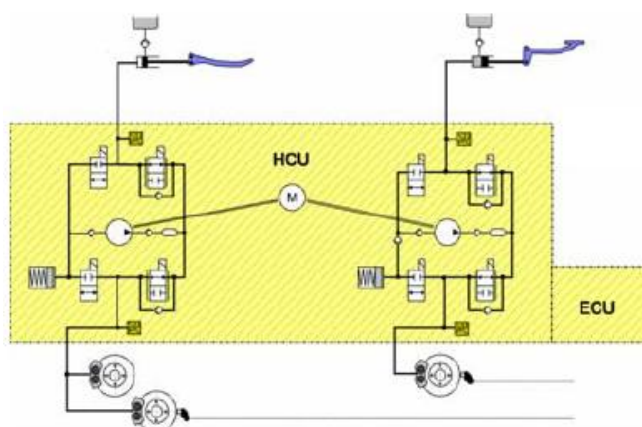

Figure 7. Motorcycle Integral Brake System (MIB) Full Integral Brake Function.

The functionality is same as that of the partial integral brake system, besides that moreover the rider input is also measured at the rear wheel control. Braking pressure can also be applied to the front wheel corresponding to the riding conditions and desired function.

VII. Conclusion

In this paper different Hydraulic Brake system for Motorcycle was analyzed. Liquids are used in hydraulic systems because liquids are incompressible. If we use a gas, on increasing the pressure, the gas could be compressed into a smaller volume due to which there will be no transmission of force or motion. In Brake systems for motorcycles are available in many distinct designs with different technical solutions. A mixed brake system can be created to enhance safety and comfort by way of setting up a hydraulic connection between the front brake control and the rear caliper or vice versa.

References

- [1]. U.S. Energy Protection Agency. World's First Full-Size Hydraulic Hybrid SUV. Presented at 2004 SAE World Congress, Detroit, MI, USA, 8–11 March 2004; EPA420-F-04-019.
- [2]. Donne, G.L., "Development of Anti-Locking Brakes for Motorcycles", Proceedings of Anti-Lock Braking Systems for Road Vehicles, London, 1985.
- [3]. Tobias Eriksson, "Co-simulation of full vehicle model in Adams and anti-lock brake system model in Simulink", 2014.
- [4]. Tianku Fu, "Modelling and performance analysis of ABS system with non-linear control", 2000.
- [5]. Mabie, H., "Mechanism and Dynamics of Machinery", John Wiley & Sons, 1987.
- [6]. Lu, C. Y., Shih, M. C., "Design of a Hydraulic AntiLock Braking Modulator and an Intelligent Brake Pressure Controller for a Light Motorcycle", Vehicle System Dynamics, Vol. 43, No. 2, 2005, pp. 217-232.
- [7]. Hoffman, O., Eckert, A., Woywod, J. "The Motorcycle Integral Brakesystem MIB: an advanced brake solution for high performance motorcycles", 6. Internationale Motorradkonferenz, Köln, 9.-10.10.2006.