

Diesel Engine Exhaust Valve Design and Optimization

Snehal S.Gawale¹, Dr.S.N.Shelke²

¹(Department of mechanical engineering, GES's R. H. Sapat COE, Nashik-422005, Maharashtra, India)

²(Department of mechanical engineering, GES's R. H. Sapat COE, Nashik-422005, Maharashtra, India)

Abstract: Smooth-running of internal combustion engine is possible because of exhaust valve. Role of the exhaust valve is to pass on the exhaust gases to the exhaust manifold from the combustion chamber. During the operation of internal combustion engine, exhaust valves are subjected to the axial stresses due to exhaust gas pressure, cyclic stresses due to return spring load, thermal stresses due to very high temperature inside the combustion chamber and inertia force arising on the account of valve assembly. The result of which maximum stress concentration is at the junction of fillet and valve stem of exhaust valve. In this paper, diesel engine's exhaust valve is designed by selecting suitable fillet radius to reduce the stress concentration further best alternative material is recommended through finite element analysis in order to increase the working life of exhaust valve and experimental validation is done by testing the valve over an Universal Testing Machine for compressive loading.

Keywords: Exhaust valve, Fillet, Finite element analysis, Stress concentration, Universal testing machine etc.

I. Introduction

Exhaust valve is termed as essential component of an IC engine as it provides path to expel out the exhaust gases generated after combustion of the fuel in the combustion chamber. If there is improper design of exhaust valve then it indirectly affects its reliability i.e. exhaust valve fails before performing its intended function and thus the following stroke will begin to mix with exhaust fumes rather than clean air. This may be inadequate for proper combustion and it leads to poor running conditions. Exhaust valve fail at higher rate than intake valve. Because intake valves are virtually cooled by fresh air, however exhaust valves are subjected to a very high temperature burnt gases. Because of that it can be exposed to very high thermal stresses more than intake valves and hence there are more chances of failure of exhaust valves rather than intake valves. The detailed literature is available relevant to the proposed study.

II. Literature review

Sagar. S Deshpande et al. [1] conducted Experimental Investigation and Analysis of Engine Valve Designs for Enhanced Fatigue Life. B.E. Gajbhiye et al. [2] proposed the Vibration Testing and Performance Analysis of IC Exhaust Valve Using Finite Element Technique. Aim of this paper is to find out effects of vibration on exhaust valve. Yuvraj K Lavhale et al. [3] proposed the Overview of Failure Trend of Inlet & Exhaust Valve. In this work Different modes of failure of valves, Methods of fracture analysis were used for valve failure analysis. Kum-Chul et al. [4] proposed the study of durability analysis methodology for engine valve considering head thermal deformation and dynamic behavior. In this paper durability analysis based on thermal deformation and dynamic behavior. Rohit T. Londhe et al. [5] proposed the Valve and Valve Seats Wear analysis experimentally in CNG Fuelled Engine. This paper gives material for valve and valve seat in gas fuel engine. Ajay Pandey et al. [6] studied the failures of automobile valves as a part of analysis. The valve microstructure change were analyzed with the aid of SEM. Bo Wong et al. [7] studied the thermal deformation field of exhaust valve used in steam booster pump based on ANSYS. Simulation results show that the thermal deformation value of the new type of exhaust valve is less than the traditional exhaust valve. Grzegorz Maciejewski et al. [8] proposed robust and simple optimization method of functionally graded material (FGM) for combined loading with application to valve design. S. M. Jafari et al. [9] proposed the Valve Fault Diagnosis in Internal Combustion Engines using Acoustic Emission and Artificial Neural Network. Goli Udaya Kumar et al. [10] proposed the Failure Analysis of Internal Combustion Engine Valves by using ANSYS. The present study is focused on different failure modes of IC engine valves. M. Azadi et al. [11] conducted a failure analysis of failed intake valve of gasoline engine. Material examination by a light microscope and also a scanning electron microscope were conducted on the fracture surface. A. S. More et al. [12] proposed the analysis of Valve Mechanism – A Review. In this proposed work dynamic and kinematic analysis of IC engine is done. Sanoj. T et al. [13] proposed the Thermo Mechanical Analysis of Engine Valve. In this thermal and structural analysis of valve with different materials (Nimonic 80A and Nimonic 105A) were used for valve analysis. Naresh Kr. Raghuvanshi et.al [14] had given a review on the failure analysis of IC engine valves. From the study, it is quite evident that a common cause of valve fracture is fatigue. Jae Soo Hong et al. [15]

studied the exhaust valve and valve seat wear depending on fuel type. He concluded that the abrasive wear was observed only in the specimen for the test performed with LPG fuel. J.-G. IH et al. [16] presented an optimal design of the exhaust system layout to suppress the discharge noise from an idling engine. Jerzy Jaskólski et al. [17] focused on the temperature and Stress Fields of valves of IC Engine and performed structural and thermal analysis to notice the temperature computed in the middle are too low. P. Forsberg et al. [18] proposed the Wear mechanism study of exhaust valve system in modern heavy duty combustion engines. Nurten Vardar et al. [19] investigated the failure of Exhaust Valve in Heavy duty Diesel Engine. Oh Geon Kwon et al. [20] investigated the valve stem failure of exhaust valve from a waukesha P9390 GSI gas engine. He concluded that the valve failed as a result of overheating.

From the literature review it is seen that most of the studies on exhaust valve design had focused on fatigue behavior, wear behavior, deformation mechanisms in metallic materials. However, very less research is done in design of exhaust valve based on optimization of its parameter i.e. fillet radius, valve stem diameter, valve head diameter. Therefore this study is conducted to design the exhaust valve by optimizing the fillet radius and recommending the best alternative material for valve through experimentation and validation in order to increase the working life of exhaust valve.

III. Problem Definition

3.1 Specification of the problem

In exhaust valve, there is sudden change in cross section due to presence of valve stem as a small shaft and valve head as a small disc, which is a functional requirement of exhaust valve. Such a discontinuities in cross of exhaust valve generates maximum stress concentration at the junction where there is abrupt change in cross section. It is impossible to eliminate presence of stress concentration totally but its reduction is possible to some extent. Change in cross sectional area should be gradual to the possible extent, hence fillet is provided at the junction. Thus stress concentration level can be reduced by selecting suitable fillet radius. Thus problem statement is “to design the valve with modeling & structural analysis by selecting suitable fillet radius for which stresses are less and recommending the best alternative material by finite element analysis, so that valve can withstand to given operating conditions and to verify it experimentally on UTM.”

3.2 Objectives

- a) Study the valve mechanism basics and failure modes in exhaust valve.
- b) Design the valve as per the specification and model it in CATIA and analyze it in ANSYS software.
- b) Find the cause of failure in existing valve.
- d) Take necessary corrections in design and modify it in order to eliminate the cause of failure.
- c) Study the different valve materials and recommend the best alternative material for valve with stress and weight as a selection criterion
- d) Conduct test on Universal Testing Machine to find stress and strain for experimental validation

3.3 Specification of the existing valve

4-Stroke CI engine-

- a) Bore x Stroke (D X L) = 120 x 125 (mm), b) Valve seat angle, $\alpha = 45^0$, c) Gas Velocity, $v_g = 2100\text{m/min}$
- d) Length of stem = 10.5 cm, e) Engine speed, $N_s = 1150\text{ rpm}$, f) Max. Gas Pressure, $P_{\text{max}} = 6.0\text{ N/mm}^2$
- g) Mean Piston Speed, $N = 275\text{ m/min}$, h) Exhaust valve Temperature, $T = 750^0\text{C}$

3.4 Material properties of existing valve

Table 1. Material Properties of the existing valve

Material properties	Symbol	Values for Martensitic steels VV45
Density	ρ	7627-6611 kg/m ³
Young's Modulus	E	210 GPa
Ultimate Tensile Strength	S_{ut}	776 MPa
Yield Strength	S_{yt}	314-387 MPa
Composition		Mn=0.4 %, C = 0.45%, Si=3.30 %, S=8.6 %

IV. Design of Exhaust Valve

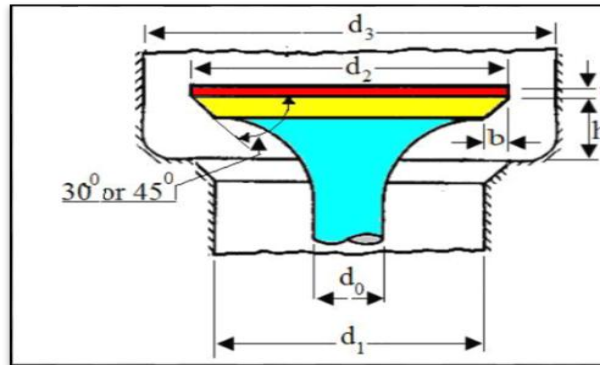

Fig 1. Geometry of exhaust valve

4.1 Design dimensions

(i) Port diameter (d_1) is calculated as: $d_1 = D \sqrt{\frac{N}{v_g}} \therefore d_1 = 43.42 \text{ mm}$ (1)

(ii) Valve lift (h) is calculated as: $h = \left(\frac{0.25d_1}{\cos \alpha} \right) \therefore h = 15.35 \text{ mm}$ (2)

(iii) Port area (a) is calculated as: $a = \frac{1}{4} \pi d_1^2 \therefore a = 1480.70 \text{ mm}^2$ (3)

(iv) Thickness of valve disc (t) is calculated as: $t = k_1 d_1 \sqrt{\frac{P_{\max}}{\sigma}} \therefore t = 5.89 \text{ mm}$ (4)

Where, $K_1 = 0.42$ (for carbon steel) & Allowable stress, $\sigma = 57.5 \text{ MPa}$

(v) Valve head Diameter (d_2) is calculated as: $d_2 = d_1 + 2[t \sin(90^\circ - \alpha)] \therefore d_2 = 51.74 \text{ mm}$ (5)

(vi) Diameter of valve head opening (d_3): $d_3 = \sqrt{d_1^2 + d_2^2} \therefore d_3 = 67.55 \text{ mm}$ (6)

(vii) Width of seating (b): $b = 0.5 (d_2 - d_1) \therefore b = 4.16 \text{ mm}$ (7)

(viii) Diameter of valve stem (d_o) is calculated as: $d_o = \frac{d_1}{8} + 4 \therefore d_o = 9.42 \text{ mm}$ (8)

(ix) Diameter check: $0.7854 (d_3^2 - d_2^2) \geq 0.7854 d_1^2 \therefore 1480.83 \geq 1480.71$ (Hence design is safe) (9)

(x) Size of valve ports Check: $V_g \times a = A_p \times C_{p_{\text{avg}}}$ (10)

Where, V_g is velocity of gas ≈ 2000 to 3300 m/min -for stationary engines
 $= 3300$ to 5000 m/min -for automobile engines

$$A_p = \frac{1}{4} \pi D^2 = 11309.73 \text{ mm}^2$$

$$C_{p_{\text{ave}}} = \text{average piston velocity} = 2 L N_s = 2 \times 0.125 \times 1150 = 287.5 \text{ m/min}$$

$$\text{Hence, } a = 1.548 \times 10^{-3} \text{ mm}^2$$

Thus, $d = 43.40 \text{ mm}$ (Hence design is safe)

(xi) $V_g' = \frac{14.7 V_g T \eta_{ch} 190}{520 P \times (190 + \alpha + \beta)}$ (11)

V_g' : For Stationary engines $\leq 18000 \text{ ft/min}$ – (exhaust valve).

: For Automobile engines $\leq 27000 \text{ ft/min}$ – (exhaust valve).

Where, a) Gas velocity fixed, V_g' in ft/min,

b) Exhaust temp. In Rankin – $T(R) = T^\circ F + 459.67$,

c) Exhaust valve avg temp $\approx 400^\circ C = 752^\circ F = 1211.67 \text{ R}$,

d) Charging efficiency, $\eta_{ch} \approx 85\%$;

e) Pressure of gas, $P = 14.7 \text{ psi}$,

f) Opening advance, $\alpha = 45^\circ$,

g) Closing delay, $\beta = 10$ to 20°

h) Duration of valve opening, $(180 + \alpha + \beta) = 240^\circ$

Thus, $V_g' = 10234.47 \text{ ft/min} \leq 18000 \text{ ft/min}$ (Hence design is safe)

4.2 Dimensions of exhaust valve

Table 2. Calculated dimensions of exhaust valve

Sr. no	Design Parameter	Symbol	Dimension
1.	Port Diameter	d1	43.42
2.	Valve lift	h	15.35
3.	Thickness of valve disc	t	5.89
4.	Valve head Diameter	d2	51.74
5.	Width of seating	b	4.16
6.	Diameter of valve stem	do	9.42

4.3 Valve drawing with design dimensions

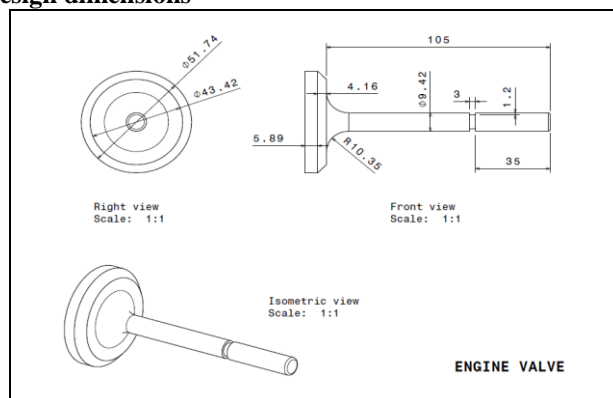

Fig 2. Valve Drawing with design dimensions

4.4 Force calculation

Table 3. Forces acting on the Valve

Force acting on exhaust valve	Formula	Values
Force due to gas pressure (F_G)	$F_G = \frac{\pi}{4} d_2^2 P_c$	946.14 N
Inertia force (F_A)	$F_A = m \times a'$ $= 2m \pi^2 \omega^2 h / \Theta \text{cam}^2$	36.15 N
Initial spring force (F_I)	$F_I = \frac{\pi}{4} d_2^2 P_s$	52.56 N
Total force (F_T)	$F_T = F_G + F_A + F_I$	1034.85 N

Tensile force generated due to inertia ($F_A=36.15 \text{ N}$) and compressive force due to gas pressure and initial spring force ($F_G + F_I = 946.14 + 52.56 = 998.7 \text{ N}$).

V. Methodology for Fillet radius selection

5.1 Numerical Method

CATIA model is made by using valve drawing and converted into .igs file which is then imported in the ANSYS workbench. Existing material (martensitic steel vv45) properties has added in engineering data. After that meshing of imported model is done using mesh option.

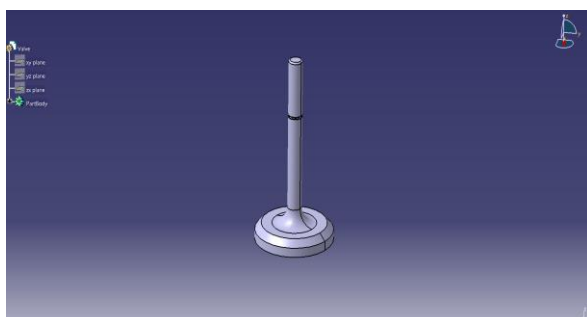

Fig.3 (a). CATIA model with 10.35 mm fillet radius

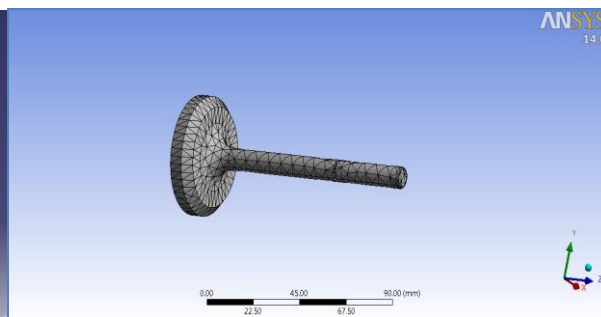

Fig.3 (b). Meshed model with 10.35 mm fillet

Fig.3 (a) shows the CATIA model of exhaust valve with 10.35 as its fillet radius and Fig. 3(b) shows the tetrahedral meshing of exhaust valve model with 10.35 mm fillet radius. The mesh should be finer and accurately represent the geometry in the critical areas i.e. the areas where stress is going to be important. Force is applied through the option loads and fix support is provided through option displacement. After applying forces and supports in solution menu, von misses is selected through stresses option and by pressing solve button, solution is obtained for said quantities.

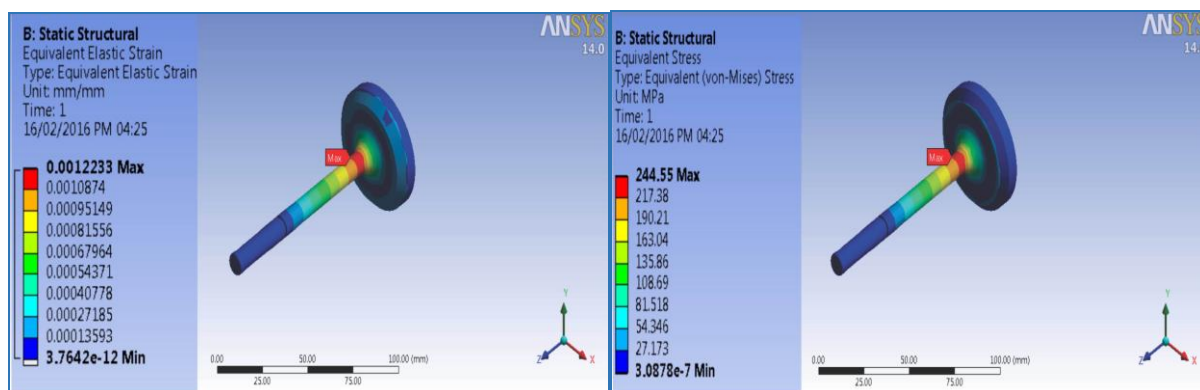

Fig.3(c).Elastic Strain for valve model with 10.35 fillet Fig.3 (d). Von misses stress for valve with 10.35 fillet

5.2 Material properties of existing valve

Table 4. Fillet radius trials to modify the design of existing valve

Trial	Radius, (mm)	Elastic Strain, (mm/mm)	Von Mises Stress, (MPa)
1	0	0.0017041	337.3
2	2.5	0.0015502	309.3
3	5.0	0.0013725	272.82
4	7.5	0.0012995	259.51
5	10.35	0.0012233	244.55
6	12.5	0.0011452	228.79
7	13.0	0.0011121	222.23
8	13.5	0.0011032	220.51
9	14.0	0.0010853	216.91
10	14.5	0.0010658	213.01
11	15.0	0.0010593	211.68
12	15.5	0.0010705	213.85
13	16.0	0.0010754	214.43
14	17.0	0.0010869	216.73

It is observed that maximum stress concentration is at the junction which is equal to the 244.55 MPa, greater than allowable stress of existing material (i.e. martensitic steel vv45). So, there is need to adopt some changes in design to reduce the stress concentration. Thus, suitable fillet radius selection is the only factor to adopt changes in the design of exhaust valve. Because all the other exhaust valve’s design parameters has design constraint due to size restriction. Hence, in this paper different trials are taken for the fillet radius by static structural analysis and using finite element analysis and suitable fillet radius is selected for which stress generated is less by considering the size restrictions. Allowable stress is 233.33 MPa considering the yield stress, $S_{yt} = 350$ MPa and factor of safety, $FOS = 1.5$.

From the above results tabulated in Table 4, it can be seen that after 15.0 mm fillet radius stresses generated are again increasing beyond 15 mm fillet radius. Because when we increases the fillet radius, it means that we are adding more material to the root portion. So, root section becomes more strong as compared to valve stem section i.e. stem becomes weak as compared to valve head. Thus, stress starts increasing. Hence 15.5, 16 and 17 mm can’t be selected. Due to valve seat arrangement and size restriction, maximum radius we can afford to select is 14.0 mm for which von mises stress is 216.91MPa less than allowable stress 233.33MPa, and hence fillet radius for further work is 14.0 mm. Fig 4 shows the graph plotted for stress generated in exhaust valve by changing the valve fillet radius.

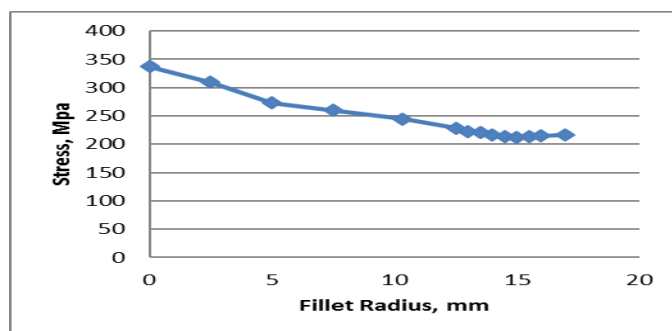

Fig.4. Graph of von mises stress vs fillet radius

5.3 Stress comparison for valve with existing & selected fillet radius modeled with same material (Martensitic steel VV45)

Table 5. Stress comparison

Sr No.	Fillet radius (mm)	Von mises stress (MPa)	Allowable stress (Mpa)
1.	10.35 (initial)	244.55	233.33
2.	14 (new one)	216.91	233.33

Elastic strain and von mises stress for the exhaust valve with selected fillet radius i.e. 14 mm is shown in the Fig. 5(c) and Fig. 5(d):

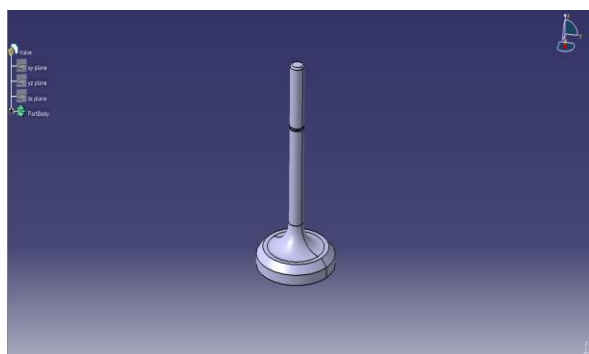

Fig.5 (a). CATIA model with 14 mm fillet radius

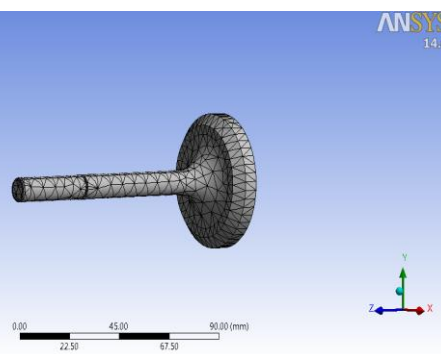

Fig.5 (b). Elastic Strain for model with 14 mm fillet

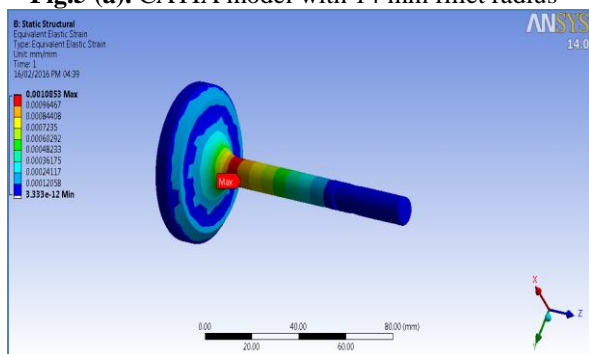

Fig.5(c). Elastic Strain for model with 14 mm fillet

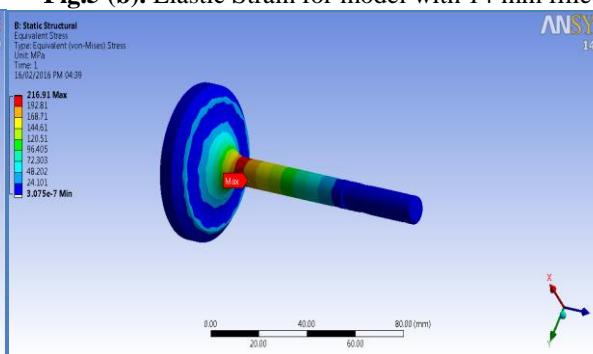

Fig.5(d). Von mises stress for model with 14 mm fillet

5.3 Material selection

Table 6. Alternative material properties to choose best alternative

Selected material	Super Alloy 21-2N Valve Steel	AISI 1541 Carbon Steel	Austenitic Steel- 23-8N
Density	7.60 g/cm ³	7.90 g/cm ³	7.800 g/cm ³
Young's Modulus (E)	215 GPa	190-210 GPa	193 GPa
Yield Strength	440-580 MPa	380 to 650 MPa	550 MPa
Composition	Mn=8.5 %, C = 0.55%, Si=0.25 %, Ni=2.13 % Mo=0.50%, Cr=20.2%	Mn=1.35-1.65%, C = 0.360-0.44%, Fe=97.82-98.29%, P=0.040%,S=0.050%	Mn=3-4%, C = 0.3-0.35%, Cr=22-24%, Ni=7-9%,Si=0.6-0.9%

To provide alternative material for exhaust valve, material properties in engineering data of ANSYS are edited and static structural analysis is done to find von mises stresses and elastic strain. Results of obtained

for valve model with fillet radius 14 mm by applying different materials in ANSYS are tabulated as below which helps in selecting the best alternative to existing valve material in order to reduce the stress concentration further and thus to improve the working life of exhaust valve.

Table 7. Results based on material for fillet radius 14 mm

Material	Elastic Strain, mm/mm	Von Mises Stress, MPa	Allowable Stress, MPa	Volume, mm ³	Density kg/m ³	Weight, g
Martensitic steels VV45	0.0010853	216.91	233.33	29146	7500	218.6
21-2N	0.0010702	213.87	293.33	29146	7600	221.5
AISI 1541	0.0011084	221.5	266.67	29146	7900	230.2
Austenitic Steel 23-8N	0.0010885	216.92	366.67	29146	7800	227.3

From the above result it can be seen that percentage of von- mises stress and weight for material 21-2N is lower compare to other materials. Thus, material super alloy 21-2N steel gives us better results, hence can be used as an alternative to existing material of exhaust valve.

VI. Experimental Method

6.1 Experimental set up information:

Table 8. UTM specification

Max Load Capacity	Load Accuracy	Test Space		Piston Stroke	Dimensions	Power Supply
		Tensile	Compression			
100 KN	Within +/- 1%	550 mm	500 mm	200 mm	750*600*2100 mm	Three-Phase, 240V-50HZ



Fig 6.UTM set up for testing of exhaust valve



Fig 7.Exhaust valve testing fixture

Fig 6 shows the UTM setup for the exhaust valve testing. Fig.7 shows the fixture designed for testing the exhaust valve. graph of elastic strain vs. load. It is observed that when the force is applied gradually from 0 to 998.7 N, strain increases from 0 to 0.00108 mm/mm.

Table 9. Observation chart

Material	Fillet radius mm	Load N	Elastic strain mm/mm (Experimental)	Stress N/mm ² (UTM)	Stress N/mm ² (FEA)	% Deviation in stress
Martensitic steels VV45	14 mm	998.7	0.00114	239.4	216.91	9.39
Super alloy 21-2N	14 mm	998.7	0.00108	232.2	213.87	7.89
AISI 1541	14 mm	998.7	0.00135	256.5	221.5	13.64
Austenitic Steel 23-8N	14 mm	998.7	0.00119	229.67	216.92	5.55



Fig 8. Components of exhaust valve (14mm fillet radius) to be tested



Fig 9. Tested component of Exhaust valve of 14mm fillet radius

VII. Results and Discussion

Table 10. Results and discussions

Parameter	% Reduction in stress
Due to change adopted in fillet radius (i.e. design): radius:10.35mm & Material: Martensitic steel VV45) to (fillet radius:14 mm & Material: Martensitic steel VV45)	(fillet radius:14mm & Material: Martensitic steel VV45) 11.30 %
Due to change adopted in material: Material: Martensitic steel VV45) to (fillet radius:14 mm & Material: Super Alloy 21-2N Valve Steel)	(fillet radius:14mm & Material: Super Alloy 21-2N Valve Steel) 1.40 %
Due to change adopted both in fillet radius & material: Material: Martensitic steel VV45) to (fillet radius:14 mm & Material: Super Alloy 21-2N Valve Steel)	(fillet radius:14mm & Material: Super Alloy 21-2N Valve Steel) 14.35 %
% deviation in stress obtained by FEA and UTM for valve with (fillet radius:14 mm & Material: Super Alloy 21-2N Valve Steel)	8.32 %

VIII. Conclusion

Improper selection of fillet radius leads to exhaust valve failure. Thus, fillet radius plays important role in exhaust valve failure and should be carefully selected. Valve with fillet radius 14.0 mm shows safe results and is selected for further work. Overall reduction in stress is 14.35 % and weight is on greater side by 1.29 % (For 21-2N material) and is not a big issue considering stress reduction.

IX. Future Scope

- Valve shape optimization with new shapes of valve than existing can be studied.
- Instead of static analysis, dynamic Analysis can be done.
- Thermal analysis for temperature effect study can be included for further improvement.

- d) Vibration analysis can be performed on valve by using FFT.
- e) Modal analysis can be added to study natural frequencies and their behavior for various frequencies

References

- [1]. Sagar. S Deshpande et al., Experimental Investigation and Analysis of Engine Valve Designs for Enhanced Fatigue Life, International Engineering Research Journal (IERJ) Volume 1, Issue 2, pp 788-797, 2015.
- [2]. B.E.Gajbhiye et al., Vibration Testing and Performance Analysis of IC Exhaust Valve Using Finite Element Technique, at International Journal of Research in Advent Technology, Volume 2, 2014.
- [3]. Yuvraj K Lavhale et al. Overview of Failure Trend of Inlet & Exhaust Valve, at International Journal of Mechanical Engineering and Technology (IJMET), Volume 5, Issue 3, pp 104-113, 2014.
- [4]. Kum-Chul et al., A Study of Durability Analysis Methodology for Engine Valve Considering Head, Thermal Deformation and Dynamic Behaviour of R&D Center, Hyundai Motor Company, at 2014 SIMULIA Community Conference.
- [5]. Rohit T. Londhe et al., Experimental Analysis of valve and valve Seat Wears, in gases (CNG) Fuelled Engine at IOSR Journal of Mechanical and Civil Engineering (IOSR-JMCE), Volume 11, Issue 4, pp 56-62, 2014.
- [6]. Ajay Pandey, Effects of High Temperature on the Microstructure of Automotive Engine Valves”. Int. Journal of Engineering Research and Applications www.ijera.com, Volume 4, Issue 3 (Version 1), pp.122-126, 2014.
- [7]. Bo Wua et al., Research on the Thermal Deformation Field of Exhaust Valve for High Temperature Steam Booster Pump Based on ANSYS, International Conference on Electronic & Mechanical Engineering and Information Technology 2011.
- [8]. Grzegorz Maciejewski et al., Optimization of functionally gradient materials in valve design under cyclic thermal and mechanical loading, Computer Assisted Methods in Engineering and Science, 20: 99–112, 2013. Copyright c 2013 by Institute of Fundamental Technological Research, Polish Academy of Sciences.
- [9]. S. M. Jafari et al., Valve Fault Diagnosis in Internal Combustion Engines Using Acoustic Emission and Artificial Neural Network, Hindawi Publishing Corporation Shock and Vibration Volume 2014, Article ID 823514, 9 pages.
- [10]. Goli Udaya Kumar et al., Failure Analysis of Internal Combustion Engine Valves by using ANSYS, at American International Journal of Research in Science, Technology, Engineering & Mathematics, 5(2), pp 169-173, 2014.
- [11]. A. S. More et al., Analysis of Valve Mechanism – A Review, at International Journal IOSR Journal of Mechanical and Civil Engineering (IOSR-JMCE), pp 06-09, 2012.
- [12]. Sanoj. T et al., Thermo Mechanical Analysis of Engine Valve at International Journal of Science and Research (IJSR), Volume 3 Issue 5, 2014.
- [13]. Naresh Kr. Raghuwanshi et al., Failure Analysis of Internal Combustion Engine Valves: A Review, by International Journal of Innovative Research in Science, Engineering and Technology, Volume 1, Issue 2, 2012.
- [14]. Jae Soo Hong et al., Study on Exhaust Valve and Seat Insert Wear Depending on Fuel Type, International Journal Of Precision Engineering And Manufacturing, Volume 13, No. 2, pp. 253-260, 2012.
- [15]. J.-G. IH et al., Optimal Design Of The Exhaust System Layout To Suppress The Discharge Noise From An Idling Engine, International Journal of Automotive Technology, Vol. 12, No. 4, pp. 617–630, 2011.
- [16]. Jerzy Jaskolski et al., The Temperature - and Stress Fields of Valves of IC Engine, at Journal of KONES Power train and Transport, Vol.14, No. 3 2007.
- [17]. P. Forseberg et al., Wear mechanism study of exhaust valve system in modern heavy duty combustion engines, journal homepage:www.elsevier.com/locate/wear Wear 271, pp 2477– 2484, 2011.
- [18]. Nurten VARDAR et al., Investigation of Exhaust Valve Failure in Heavy – duty Diesel Engine, Gazi University Journal of Science GU J Sci 23(4):493-499, 2010.
- [19]. Oh Geon Kwon et al., Failure analysis of the exhaust valve stem from a Waukesha P9390 GSI gas engine, Engineering Failure Analysis 11, pp 439-447, 2004.