

Error Compensation Technology for Straightening Of a Linear Guide Rail Based On Wireless Sensor Network

Lu Hong, Okonkwo Valentine Tochukwu, Gao chen, Chen meng Chun

School of Mechanical and Electronic Engineering, Wuhan University of Technology Wuhan, 430070 China

Abstract: Straightening process is one of the most important processes to improve straightness of linear motion components. The most urgent problems to be solved by the precision straightening process are the residual deflection caused by elastic rebound, and obtaining accurate straightening stroke. Stroke-deflection model is one of the most critical factors that decides the precision and efficiency of straightening process. However, semi-finished linear guide rail often slightly bent or twisted in a variety of processing and transportation process, and these deformation often need precision straightening to ensure that the guide rail straightness of the finished product. Improving the straightening precision of the linear guide rail is to improve the guide rail precision straightening mechanical machining accuracy. This paper is about the error compensation method for precision straightening machine prototype based on WSN (Wireless Sensor Network), which involves certain experimental methods. With the linear guide rails as a case study, the WSN experiments were carried out in which two symmetric full-bridge circuits were used to measure the strain data. The feasibility of error compensation scheme was verified in this paper.

Key words: Linear guide rail, Straightening machine, Error compensation, Wireless sensor network (WSN)

I. Introduction

Precision machines are essential elements in fabricating high quality products and directly affecting machining accuracy. With the advancement in technology as regards machinery, the composition of its equipment parts require higher accuracy. Machine parts including the spindle and bearing, ball silk rod, lacer detection device, linear guide rail e.t.c. The linear guide rail which is of emphasis in this paper supports and ensures linear guide of components. Due to varieties of processing and transportation process, semi-finished linear guide rail are often slightly bent or twisted and these deformation often need precision straightening to ensure straightness of the finished product. The straightness of metal bars are usually not precise enough to meet the industrial requirements, therefore, they must be straightened for various kinds of high precision products^[1]. Improving the straightening precision of the linear guide rail is to improve the guide rail precision straightening mechanical machining accuracy. Methods for increasing accuracy of precision linear guide rail straightening machine vary, people basically use the error preventive method and error compensation method, the error compensation method is a more economic and effective way for improvement of the precision of the straightening machine. The quest for improving the accuracy of machine tool and to minimize errors during machining has led researchers to an in-depth study of the situation, proposing different cost effective method to improve the manufacturing equipment precision^[2]. In 2002, Bohez for example proposed an approach based on rigid body assumption to compensate the 39 independent systematic error components for five-axis NC machining through closed loop volumetric error relations^[3]. Lee et al proposed a recursive compensation method to compensate the miniaturized machine tool in 2005^[4]. In 2007, Hsu et al. presented a new decouple compensation method for geometry errors of five-axis machine tools^[5]. In all, the researchers through the study had made attempts in finding a way to compensate the machine in different perspective. In a nutshell, the purpose of this paper is to establish the change of strain caused by the deformation, to improve the accuracy of stroke-deflection model and the establishment of error compensation in the process of straightening of correction model.

II. Straightening Principle And Error Compensation Technology

2.1. Straightening theory and process

Straightening machine achieves the objectives of straightening equipments by repeated bending deflection methods. Its working principle is based on the use of the straightening machine chuck and the pressure head as regards straightening. Straightening process usually adopts the reverse bending phase of an electro plastic, here the metal bar, whose initial deflection value is δ_0 , is simply supported. As the reverse bending proceeds with the concentrated load F , the metal bar generates elastic-plastic deformation and the value of reverse bending is δ_w . After unloading, parts of the metal bar generate permanent plastic deformation which is defined as δ_d , while others generate elastic rebound defined as δ_f . On the condition that the elastic rebound is

equal to the reverse bending, which can be described as $\delta_f = \delta_w$, is the metal bar straightened already^[6]. Shown as Fig.1, the straightening process is

Concluded as: $\delta_e = \delta_0 + \delta_w = \delta_d + \delta_f$

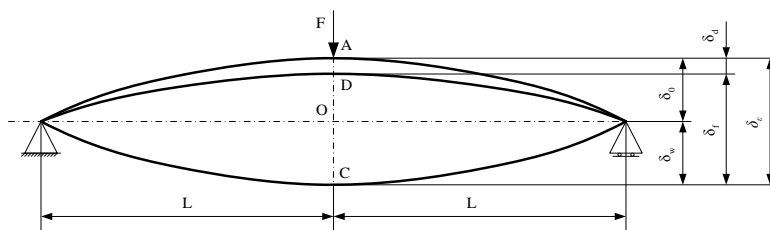

Fig.1 The process of three-point bending straightening method

2.2 Strain and deflection relationship

Making emphasis on the elastic plastic deformation of the guide rail, the mathematical relationship between the strain and deflection of the guide rail is deduced according to the computational method on curvature of the guide rail. Citing bending deformation of the material mechanics, the theoretical model of a linear guide can be established^[7]. As shown in Fig.2, the section of the guide rail is simplified as a square, with a section of the guide rail of the Y axis as the axis of symmetry whose positive direction is down, and the Z axis is the neutral axis, x-axis is normal of the cross section of the origin.

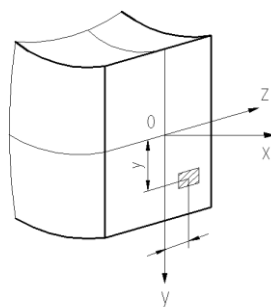

Fig.2. The simplified model of section

According to the bending deformation, the original cross-sectional plane of the frontal beam remains plane after deformation while the rear beam remains perpendicular to the axis of deformation. Sections which are dx apart rotate at dθ depending on the neutral axis. It makes length of the fiber bb resulting to^[7]:

$$\overline{b'b'} = (\rho + y)d\theta \quad (2)$$

Here, ρ is the radius of curvature of neutral plane. dx is the length of fiber bb $\overline{bb} = dx = \overline{OO}$. The length of fiber OO of neutral plane remain unchanged, the equation can be expressed as:

$$\overline{bb} = dx = \overline{OO} = \overline{O'O'} = \rho d\theta \quad (3)$$

The strain of fiber bb is expressed as:

$$\varepsilon = \frac{(\rho + y)d\theta - \rho d\theta}{\rho d\theta} = \frac{y}{\rho} \quad (4)$$

From the work piece, the distribution and deformation of material is uniform and the span is small. The curvature of AB is equal. The span $\overline{AB} = 2L$, the radius of curvature is ρ, the deflection is δ. Because of the small deformation, the curvature is far greater than AB. The continuity hypothesis can be used here, and from the equation:

$\overline{OA} = \overline{OB} = \overline{OC} = \rho$. The relationship of Fig.3 based on the Pythagorean Theorem can be expressed as:

$$\rho^2 = \left(\frac{\overline{AB}}{2}\right)^2 + (\rho - \delta)^2 \quad (5)$$

Then, the deflection can be gotten from the equation:

$$\delta = \rho - \sqrt{\rho^2 - \left(\frac{\overline{AB}}{2}\right)^2} \quad (6)$$

If $\overline{AB}=2L$, $\rho=\frac{y}{\varepsilon}$, the relationship between deflection and strain can be expressed as:

$$\delta = \frac{y}{\varepsilon} - \sqrt{\left(\frac{y}{\varepsilon}\right)^2 - L^2} \quad (7)$$

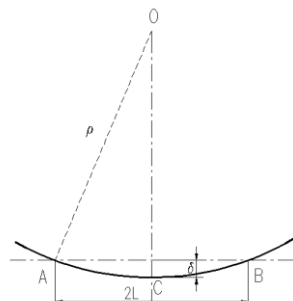

Fig.3. the mathematical model of deformation

2.3 Error Compensation Technology

In order to improve the accuracy of machine tools and accommodate for errors during machining, deformation detection experimental scheme is shown as Fig.4 and the error compensation method is an offset of the original error of the machine tool through statistics and analysis. It is a soft technology that can directly modify the software of mechanical equipment, to create a contrary to the original error equal in magnitude and direction of the new error, and can reduce or even eliminate the final error. The process of Equipment error compensation in machining is the error modeling, testing, and finally to compensate the implementation of the process. Nowadays, there is a variety of error compensation method of automation equipment, mainly divided into the following kinds: single error synthetic compensation method, indirect compensation method, error synthesis method and relative error compensation method based on decomposition, synthesis, etc.

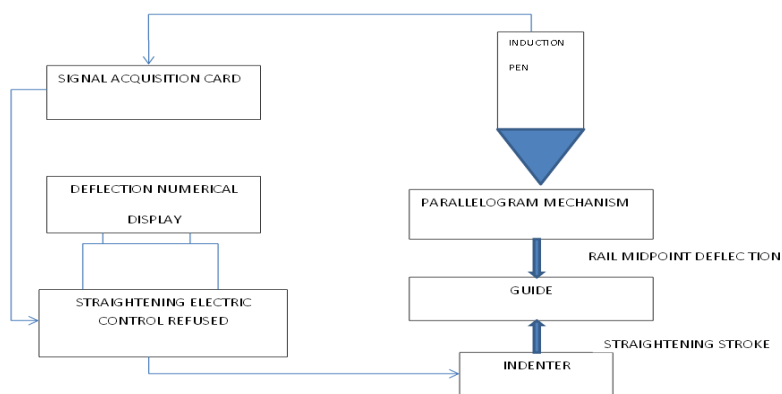

Fig. 4 deformation detection experimental scheme

III. Wireless Sensor Network Monitoring And Error Compensation Experiment

3.1 Wireless sensor network (WSN)

The wireless sensor networks (wsn) are spatially distributed sensors to monitor physical conditions and cooperatively pass their data through the network to a main location, shown as Fig.5.. The network structure of WSN is list as Fig.6. It is a self-organized multi-hop network formed by the wireless communication. The functions of the sensor nodes are those of data collection, data storage; gathering the nodes, implement the functions that the nodes control, data monitoring, data download and data transmission. Using wireless sensor network, one can realize the linear guide rail straightening process real-time monitoring of strain variation, and can eliminate long cable, etc. caused by noise jamming. The experiment for this paper, the real-time measurement of strain adopts the wireless sensor node of SG402 of BEETECH

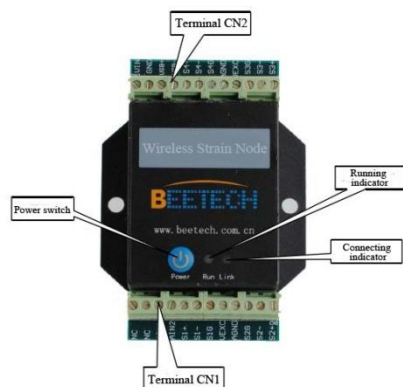

Fig 5. Wireless sensor node SG402

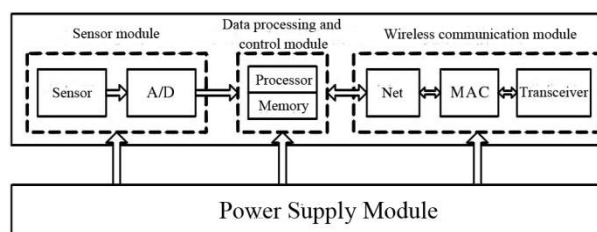

Fig 6. The network structure of WSN

This node consists of power, module for signal sampling, and module for signal sending and receiving. The Wheatstone bridge circuit used for this experiment can be connected to the node. And then the strain caused by the deformation is measured through amplifying and adjusting the circuit. The performance of the node is shown in Table.1.

Table.1. The performance of the node

Range	15000 $\mu\epsilon$
Resistance of internal bridge	120-1000 Ω
Transmitted speed of signal in the air	250K BPS
Communication distance	100m

3.2 Protocol and equipment

In order to improve compensation model or system and to achieve better accuracy, a compensation system is set up to deal with the compensation effect of the system. To test the effect of error compensation, deflection before compensation and after compensation - stroke programming model was adopted and the precision measurement verified with CMM. The equipment adopts American hexagon (Brown&Sharp) of the three coordinate measuring machine, model Global 09.12.08, Size Global 09.12.08 1450mm * 2165 mm * 2946 mm, detection range of 900 mm * 1200 mm * 800 mm. The specific implementation steps of the error compensation experiment are highlighted as follows;

- (1) Label the experiment's rail measurement point;
- (2) Start CMM, and open the corresponding computer system;
- (3) Experimental setup guide, set the machine coordinates;
- (4) Straightness measuring span portions of the rail, measured by manual model;
- (5) Completion of the experiment, the equipment back to zero, downloading data files from the computer system.

Table.2 hexagon Global models on the environmental requirements

Standard ambient temperature	18 - 22 °C
Changes in the ambient temperature range	1 °C/h - 2 °C/24h
Compensated Temperature Range	16 - 26 °C, 1 °C/h -5 °C/24h
Operating temperature	10 °C ~45 °C
relative humidity	90%, non-condensing

3.3 Experimental Procedures

Linear rail straightening deformation experiment is divided into two parts: The first part is the maximum deflection of the guide rail in the position detection. The sensor uses an inductive pen; the second part

is the detection rail strain. The sensor uses strain gauges wireless strain sensor connection. The arrangement method of strain gages of full-bridge circuit as shown as Fig.7. The schematic diagram between full-bridge circuit and internal circuit of sensor nodes as shown as Fig.8. Before the start of the experiment, the resistance strain gauges for measuring the strain of the rail are needed to form a bridge and connect the wireless strain sensor nodes. Based on the strain and deflection model, we choose the left and right ends of the rail pressure and the maximum deflection of the left and right ends of the strain gauge, and connect the two independent bridges, the design of the layout . To obtain the data when the straightening process is operating, the strain gauges should be pasted on the location of the linear guide rail near the maximal bending deformation area. The full-bridge circuit was connected at the linear guide rail, symmetrically arranged by the pressure head. The whole measurement circuit consisted of the full-bridge circuit and excitation voltage from the internal circuit of the sensor nodes. The benefit of the full-bridge circuit is that it can reduce the impact caused by line resistance and temperature. The total length of the linear guide rail is $L_0=552\text{mm}$, the span length is $2L=300\text{mm}$, the length from strain gauge to midpoint of pressure head is $d_0=10\text{mm}$.

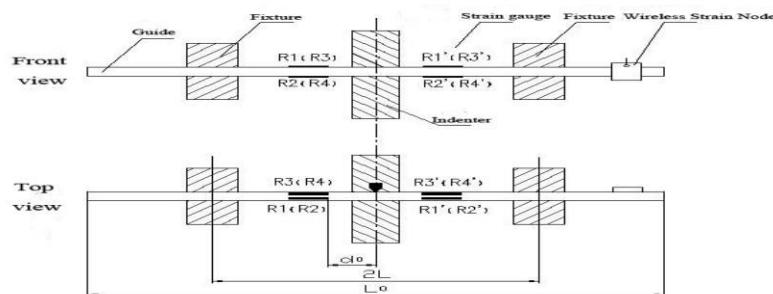

Fig. 7 the arrangement method of strain gages of full-bridge circuit

Bridge circuit and sensor node internal circuit of the overall connection principle is shown below

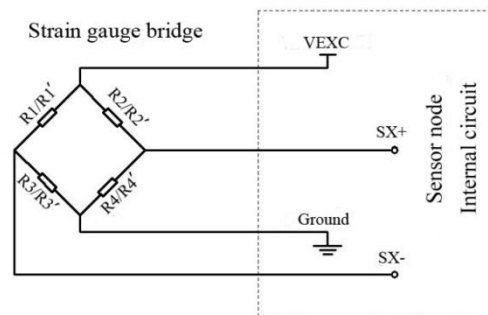

Fig. 8 The schematic diagram between full-bridge circuit and internal circuit of sensor nodes

The relationship between input voltage and output voltage is expressed as:

$$e = \frac{1}{4} \left(\frac{\Delta R1}{R1} - \frac{\Delta R2}{R2} + \frac{\Delta R3}{R3} - \frac{\Delta R4}{R4} \right) = \frac{1}{4} KE(\varepsilon_1 - \varepsilon_2 + \varepsilon_3 - \varepsilon_4) \quad (1)$$

In this equation, $R1, R2, R3, R4$ are the operating resistance, $\Delta R1, \Delta R2, \Delta R3, \Delta R4$ are the change of strain gauge under deformation, E is the bridge voltage, e is the output voltage, K is the sensitivity of resistance strain gage, $\varepsilon_1, \varepsilon_2, \varepsilon_3, \varepsilon_4$ are the strain value.

Table.3 the original data record of the wireless sensors

Load serial number	Pressure depth (mm)	Strain sensor readings (mm)	Load serial number	Pressure depth (mm)	Strain sensor readings (mm)
1	0.5	-0.01311	9	1.4	0.00119
2	0.6	-0.00699	10	1.6	0.00731
3	0.7	-0.00903	11	1.8	0.00119
4	0.8	-0.00699	12	2.0	-0.00903
5	0.9	-0.00494	13	2.1	-0.00086

6	1.1	0.00119	14	2.2	0.00323
7	1.2	-0.00086	15	2.4	0.00323
8	1.3	-0.00903	16	2.6	0.00936

The deformation value of guide rail is obtained from stable stage before loading and stable stage after deformation, which is shown through the value in the curve. And from Eq.7, where $y=14.7/2\text{mm}=7.35\text{mm}$, $L=150\text{mm}$. The transmission formula can be expressed as:

$$\delta = \frac{7.35}{\varepsilon} - \sqrt{\frac{54.0225}{\varepsilon^2} - 22500} \text{ mm}$$

The real-time data of the guide rail strain during the process of bending and springback are recorded in real time when the strain of the guide rail is detected. Software set the sampling rate of 100sps, that is, 100 data points per second. For the straightening of the head of the guide rail in a bending loading process, the BeeData software helps to monitor the real-time monitoring of the interface shown as Fig.9

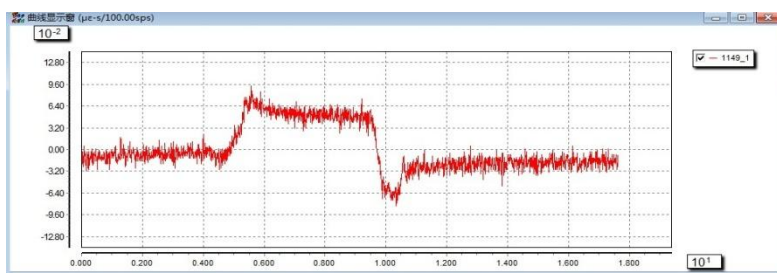

Fig. 9 The interface of experiment software

IV. Results And Analysis

During the experiment lock Z-axis direction, that is the height direction, the coordinate data relevant for this test was a track surface finishing 5-3 in the following table.

Table.4 guide before straightening straightness measurement record

Measuring point number	X axis coordinate value (mm)	Y axis coordinate value (mm)
1	181.8497	169.8637
2	181.7448	188.5499
...
7	242.2699	307.8554
8	242.1621	329.8486
9	242.1066	347.0467
...
14	181.5294	446.4392
15	181.6944	470.3039

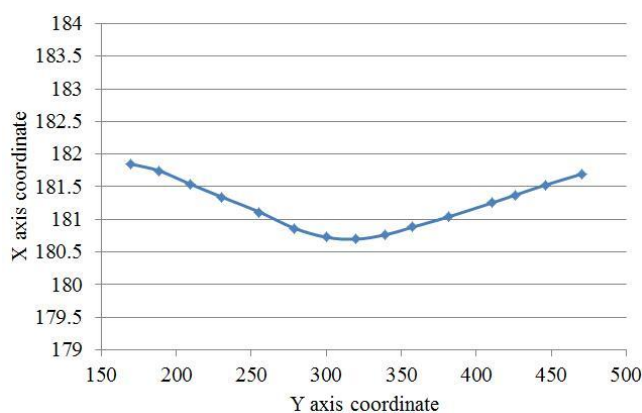

Figure.10 Guide rail initial straightness fitting curve before straining process

The above curves can be continued in the MATLAB using the least square straight line as the baseline, the distance between the two points to the baseline of the baseline distance is obtained. The straightness error of

the fitting curve is 1.0913mm, and the initial deflection of the guide rail is -0.95395mm. The linear guide rail straightening is again repeated and the data obtained in this study are shown in the following.

Table.5 measurement of straightness after straightening

Measuring point number	X axis coordinate value (mm)	Y axis coordinate value (mm)
1	242.1922	179.0685
2	242.2912	202.3735
...
7	242.2699	307.8554
8	242.1621	329.8486
9	242.1066	347.0467
...
14	242.0867	463.8599
15	242.0989	480.5654

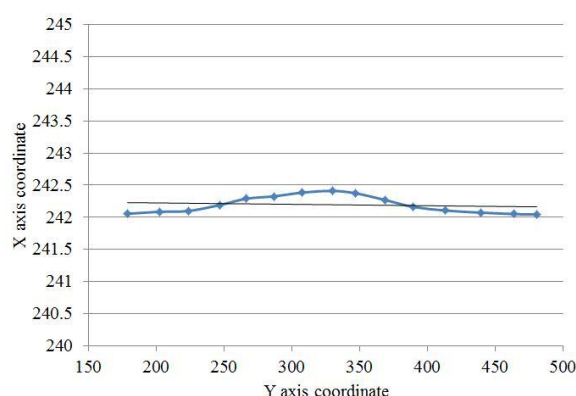

Fig.11 Guide rail initial straightness fitting curve after straining process

By the above curves can also be obtained in the MATLAB of the fitting curve of the straightness error is 0.3021 mm, the residual deflection of the guide rail is 0.06395mm.

Fig.10 and 11 shows guide rail initial straightness fitting curve before and after straining process based on the three coordinate measuring machine aided measurement. It is proved that the straightening machine through reduced rail at mid span deflection can make the span part of the linear guide rail straightness error smaller, so as to improve the guide rail straightness. The experimental results show that the error compensation scheme proposed in this paper can effectively improve the accuracy and efficiency of straightening.

V. Conclusion

With the huge Requirement of High Precision Mechanical Equipments, it is necessary to reduce deformation and error Compensation method is a Very Effective Way to Improve the Precision of Linear Guide Rail straightening Machine. To realize this, the software compensation module was used before and after the compensation to verify the compensation accuracy using three coordinate measuring machine to verify the compensation effect.

Acknowledgement

This work was supported by The National Natural Science Foundation of China (NO.51275372) , the Natural Science Foundation of Hubei Province, China (2014CFB184) .

References

- [1]. Dehong Huo and Kai Cheng (2007). "A dynamics-driven approach to precision machines design for micro-manufacturing and its implementation perspectives.". Advanced Manufacturing and Enterprise Engineering (AMEE) Department School of Engineering and Design, Brunel University, Uxbridge, Middlesex UB8 3PH, UK
- [2]. Mahbubehman RMD, Hewikkala J, Lappalainen K, Karjalinen JA (1997) Positioning accuracy improvement in five-axis milling by post processing. Int J Mach Tools Manuf 37 (2):223–236
- [3]. Bohez ELJ (2002) Compensating for systematic error in 5-axis NC machining. Computer Aided Des 34:391–403
- [4]. Lee JH, Liu Y, Yang SH (2006) Accuracy improvement of miniaturized machine tool: geometric error modeling and compensation Int J Mach Tools Manuf 46:1508–1516
- [5]. Hsu YY, Wang SS (2007) A new compensation method for geometry errors of five-axis machine tools. Int J Mach Tool Manuf 47:352–360
- [6]. LU Hong, LING He. Improvement on straightening of metal bar based on straightening stroke-deflection model. Science in China Series E: Technological Sciences.2009, 7(52), 1866-1873.
- [7]. Liu Hongwen. (2004) Mechanics of materials (Fourth Edition) [M]. Beijing: Higher Education Press: 138-141 190.