

Analysis of Mountain Bike Frame By F.E.M.

Mr. Rajeev Gupta¹, Mr. G.V.R. Seshagiri Rao²
^{1,2} (Mechanical Engineering, BMCT, Indore/ RGPV, Bhopal, India)

Abstract : Bicycles continue to be the principal mode of transport for the low and middle income families. This is because the bicycle is both environment and people friendly. India is the largest producer of bicycles next only to China. It produces around 1.26 crore bicycles every year. Considering the rising fuels cost and pollution, the bikes are considered ideal. These can be maintained at low costs. Since their inception bicycles have provided society with a source of transportation, exercise, recreation and sport. New bicycle frames are generally motivated by weight and/or stiffness considerations and often incorporate the use of high performance engineering materials. Indeed, competitive bicycling has promoted the use of various advanced structural materials including non-ferrous alloys (e.g. primarily aluminum and titanium) and reinforced polymers (e.g. carbon and graphite reinforced epoxies). Both the frame design and the material contribute to rider's energy consumption. Energy is expended for propulsion and elastic deformation of the frame. Therefore a minimization of frame's total mass and deflection are essential.

Most modern bicycle frames have simple form e.g. diamond shaped frame (Figure 2). It was in 1895 after several remained basically unchanged since that time. The need for low weight coupled with high strength and stiffness has led to continuing trail and development of high performance materials for racing bicycles. The solution to the pertaining problem is to switch to the most reliable and a proven tool of structural engineering; the Finite Element Analysis Method (FEA).

Keywords: Mountain bike frame, Finite element analysis, Frame building material tube geometry.

I. Introduction

The modeling for the frame started with development of several concepts for the performance of the frame. Once a concept was selected and sketch specific designs that would utilize the concept decided on previously. A diamond frame was selected to be designed as it was the most primary frame to be analyzed. For that a diamond framed bicycle model from a standard bicycle size geometry chart (Table 1) was selected. From that a size for a person with a height of 5 feet 10.75 inches a frame was constructed. The chart variation of the frame size with height of the rider is as follows:

Here,

C-t = This refers to the length of the seat tube, from the base to the top.

C-c = This is similar to the c-t measurement except the top of the seat tube is defined by the in the intersection of the center of the top tube and center of the seat tube.

Inseam (In.)	Height	Shoe size	Frame size cm (c-t)	Top tube cm (c-t)
36	6'4"	11.5	62	59
35.5	6'2.5"	11	61	58
34.75	6'1"	10.5	60	57.5
34.25	6'0"	10.5	59	57
33.75	5'10.75"	10	58	56.5
33	5'9.5"	9.5	57	56
32.5	5'8.75"	9	56	55.5
32	5'8"	9	55	55
31.25	5'7"	8.5	54	54.5
30.75	5'6"	8	53	54
30	5'5"	7.5	52	53
29.5	5'4.5"	7	51	52
29	5'4"	7	50	51
28.5	5'3"	6	49	51

Table 1: Standard bicycle size geometry chart



Figure 1: Tubing diagram of the bike frame

II. Review Of Frame Building Material

There are a wide variety of materials used in bicycle frames. Bike frames were originally made from wood, but modern frames are made primarily from aluminum, steel, titanium and carbon fiber. Some of the less common materials used in creating frames include bamboo, thermoplastics and magnesium. The materials used in analysis are namely:

1. Aluminum 6061-T6.
2. Aluminum 7005-T6.

The materials used for mountain bicycle frames have a wide range of mechanical properties. These properties can be seen in Table 2.

Alloy	Density (g/cc)	Modulus of Elasticity (GPa)	Poisson's Ratio	Ultimate Tensile Strength (MPa)	Tensile Yield Strength (MPa)	Shear Modulus (GPa)
Aluminum 6061-T6	2.7	68.9	0.33	310	276	26
Aluminum 7005-T6	2.78	71	0.32	370	317	27

Table 2: Mechanical properties of common bicycle frame materials

Alloys	Weldability and Machinability	Cost per kg (US \$)
Aluminum 6061-T6	Excellent	2.42
Aluminum 7005-T6	Excellent	2.87

Table 3: Properties of frame materials

Tube Geometry

Frame geometry dimensions were taken from the standard mountain bike frame to characterize the overall tube layout geometry. The dimensions taken are standard dimensions used to characterize the geometry of the frame. These dimensions can be seen in Table 4.

PARAMETER	VALUE
Head tube angle	73.5°
Seat tube angle	73.5°
Seat tube length	580 mm
Top tube length	570 mm
Chain stay length	360 mm
Head tube length	120 mm

Table 4: Geometry values for the solid model of the bicycle frame

Theoretical analysis of bike frames

The modeled bicycle frame is made to apply with following load cases as a part of the investigation of the frame. The load cases are applied on all the 5 frames individually. The load cases are namely:

- 1) Static start up.
- 2) Steady state pedaling.
- 3) Vertical impact.
- 4) Horizontal impact.
- 5) Rear wheel braking.

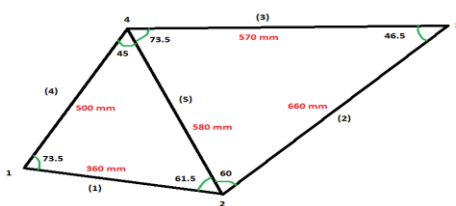

Figure 2: Bike frame truss

Finite element analysis of Mountain bike frame using ANSYS

To verify the analytical result of stresses for bicycle frame it is compared with FEA analysis. The problem to be modeled is a simple bicycle frame shown in the following figure 9. The frame is to be built of 2 different alloys (Table1).



Figure 3: Bike frame with meshing of 5mm

III. Results And Discussions

Theoretical stresses on members

As there are 2 different alloys, so we have to make 2 different tables in order to present the resultant stress in different loading cases for all alloys.

1. Aluminum 6061-T6

Load case	Normal Stresses (x-axis) in members (MPa)					
	Top tube (AB)	Down tube (AD)	Seat tube (BD)	Seat (BC) stays	Chain (CD) stays	
Static start up	2.95	0.86	5.83	2.89	0.71	
Steady state pedaling	3.29	0.99	7.2	1.51	0.81	
Vertical impact	6.23	1.31	11.87	-0.48	1.53	
Horizontal impact	7.88	7.01	0	0	0	
Rear wheel braking	0	0	0	12.76	17.23	

Table 5: Theoretical comparison of stresses on members

2. Aluminum 7005-T6

Load case	Normal Stresses (x-axis) in members (MPa)					
	Top tube (AB)	Down tube (AD)	Seat tube (BD)	Seat (BC) stays	Chain (CD) stays	
Static start up	5.13	0.18	7.93	3.13	0.08	
Steady state pedaling	6.43	0.53	9.01	4.53	2.56	
Vertical impact	10.68	2.25	15.67	7.63	2.87	
Horizontal impact	6.94	6.77	0	0	0	
Rear wheel braking	0	0	0	12.13	16.71	

Table 6: Theoretical comparison of stresses on members

Finite element analysis results by ANSYS

1. Aluminum 6061-T

Load case	Normal Stresses (x-axis) in members (MPa)					
	Top tube (AB)	Down tube (AD)	Seat tube (BD)	Seat stays (BC)	Chain stays (CD)	

Static start up	3.29	0.92	5.66	3.296	0.92
Steady state pedaling	3.76	1.097	6.4	1.095	1.003
Vertical impact	6.6	1.86	11.32	-0.51	1.86
Horizontal impact	8.17	6.3	0	0	0
Rear wheel braking	0	0	0	13.11	17.5

Table 7: Comparison of stresses on members



Figure 4: Static start up



Figure 5: Steady state pedaling



Figure 6: Vertical impact



Figure 7: Horizontal impact



Figure 8: Rear wheel braking

2. Aluminum 7005-T6

Load case	Normal Stresses (x-axis) in members (MPa)				
	Top tube (AB)	Down tube (AD)	Seat tube (BD)	Seat stays (BC)	Chain stays (CD)
Static start up	5.58	0.23	7.56	3.6	0.13
Steady state pedaling	6.57	0.56	8.77	4.37	3.9
Vertical impact	11.16	2.54	15.13	7.2	3.24
Horizontal impact	7.08	6.23	0	0	0
Rear wheel braking	0	0	0	12.64	16.87

Table 8: Comparison of stresses on members



Figure 9: Static start up



Figure 10: Steady state pedaling



Figure 11: Vertical impact



Figure 12: Horizontal impact



Figure 13: Rear wheel braking

VI. Comparison of stress on members by theoretical and F.E.A.

6.3.1 Aluminum 6061-T

a) Static start up:

	TOP TUBE	DOWN TUBE	SEAT TUBE	SEAT STAYS	CHAIN STAYS
STATIC START UP (ANALYTICAL)	2.95	0.85	5.83	2.89	0.712
STATIC START UP (FEA)	3.29	0.92	5.66	3.29	0.92
% DIFFERENCE	10.33	7.6	3	12.15	22.6

Table9: Comparison of stresses on members, Static start up

b) Steady state pedaling:

	TOP TUBE	DOWN TUBE	SEAT TUBE	SEAT STAYS	CHAIN STAYS
STEADY STATE PEDALING (ANALYTICAL)	3.29	0.99	7.2	1.51	0.81
STEADY STATE PEDALING (FEA)	3.76	1.09	6.4	1.37	1
% DIFFERENCE	12.5	9.1	12.5	10.2	19

Table 10: Comparison of stresses on members, Steady state pedaling

c) **Vertical impact:**

	TOP TUBE	DOWN TUBE	SEAT TUBE	SEAT STAYS	CHAIN STAYS
VERTICAL IMPACT (ANALYTICAL)	6.23	1.31	11.87	-0.48	1.53
VERTICAL IMPACT (FEA)	6.6	1.86	11.32	-0.51	1.86
% DIFFERENCE	5.6	29.56	4.85	5.88	17.74

Table 11: Comparison of stresses on members, Vertical impact

d) **Horizontal Impact:**

	TOP TUBE	DOWN TUBE	SEAT TUBE	SEAT STAYS	CHAIN STAYS
HORIZONTAL IMPACT (ANALYTICAL)	7.88	7.01	0	0	0
HORIZONTAL IMPACT (FEA)	8.17	6.3	0	0	0
% DIFFERENCE	3.54	11.26	0	0	0

Table 12: Comparison of stresses on members, Horizontal impact

e) **Rear wheel braking:**

	TOP TUBE	DOWN TUBE	SEAT TUBE	SEAT STAYS	CHAIN STAYS
REAR WHEEL BRAKING (ANALYTICAL)	0	0	0	12.76	17.23
REAR WHEEL BRAKING (FEA)	0	0	0	13.11	17.5
% DIFFERENCE	0	0	0	2.66	1.54

Table 13: Comparison of stresses on members, Rear wheel braking

6.3.2 Aluminum 7005-T

a) **Static start up:**

	TOP TUBE	DOWN TUBE	SEAT TUBE	SEAT STAYS	CHAIN STAYS
STATIC START UP (ANALYTICAL)	5.13	0.18	7.93	3.13	0.11
STATIC START UP (FEA)	5.58	0.23	7.56	3.6	0.13
% DIFFERENCE	8.06	21.73	4.89	13.05	15.38

Table 14: Comparison of stresses on members, Static start up

b) **Steady state pedaling:**

	TOP TUBE	DOWN TUBE	SEAT TUBE	SEAT STAYS	CHAIN STAYS
STEADY STATE PEDALING (ANALYTICAL)	6.43	0.53	9.01	4.53	3.56
STEADY STATE PEDALING (FEA)	6.57	0.56	8.77	4.37	3.9
% DIFFERENCE	2.13	5.35	2.73	3.66	8.71

Table 15: Comparison of stresses on members, Steady state pedaling

c) **Vertical impact:**

	TOP TUBE	DOWN TUBE	SEAT TUBE	SEAT STAYS	CHAIN STAYS
VERTICAL IMPACT (ANALYTICAL)	10.68	2.25	15.67	7.63	2.87
VERTICAL IMPACT (FEA)	11.16	2.54	15.13	7.2	3.24
% DIFFERENCE	4.31	11.41	3.56	5.97	11.41

Table 16: Comparison of stresses on members, Vertical impact

d) **Horizontal impact:**

	TOP TUBE	DOWN TUBE	SEAT TUBE	SEAT STAYS	CHAIN STAYS
HORIZONTAL IMPACT (ANALYTICAL)	6.94	6.77	0	0	0
HORIZONTAL IMPACT (FEA)	7.08	6.23	0	0	0
% DIFFERENCE	1.97	8.66	0	0	0

Table 17: Comparison of stresses on members, Horizontal impact

f) **Rear wheel braking:**

	TOP TUBE	DOWN TUBE	SEAT TUBE	SEAT STAYS	CHAIN STAYS

REAR WHEEL BRAKING (ANALYTICAL)	0	0	0	12.13	16.71
REAR WHEEL BRAKING (FEA)	0	0	0	12.64	16.87
% DIFFERENCE	0	0	0	4.03	0.94

Table 18: Comparison of stresses on members, Rear wheel braking

Equivalent (von-mises) stress analysis for bike frames

6.5.1 Aluminum 6061-T

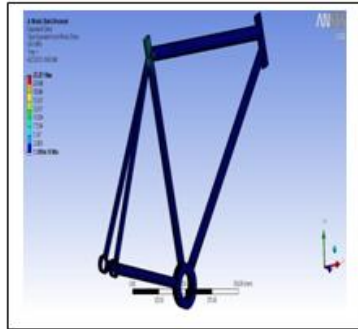

Figure 14: Equivalent stress, Static start up

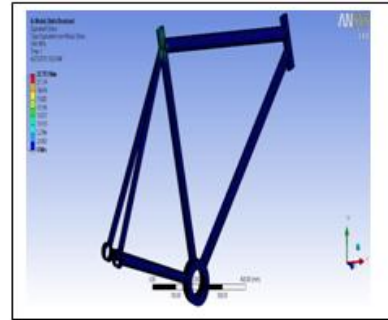

Figure 15: Equivalent stress, Steady state pedaling

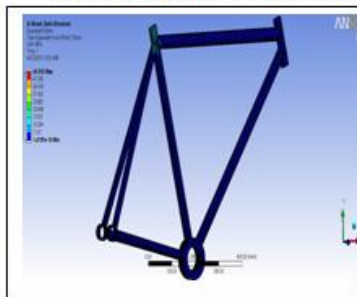

Figure 16: Equivalent stress, Vertical impact



Figure 17: Equivalent stress, Horizontal impact

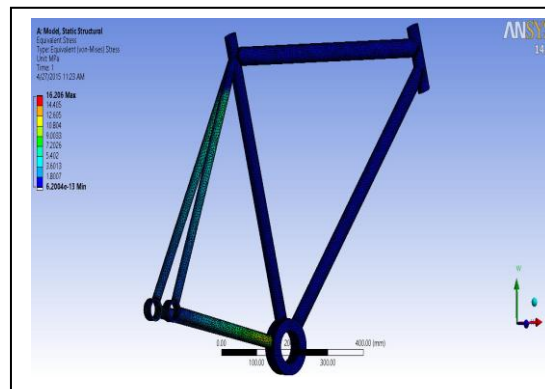

Figure 18: Equivalent stress, Rear wheel braking

Load case	Equivalent (von-Mises) Stress in members (MPa)				
	Top tube (AB)	Down tube (AD)	Seat tube (BD)	Seat stays (BC)	Chain stays (CD)
Static start up	20.66	0	23.25	18.08	0
Steady state pedaling	21.11	0	23.75	18.47	0
Vertical impact	41.33	0	46.5	36.16	0
Horizontal impact	28.96	25.75	0	0	0
Rear wheel braking	0	0	0	14.4	16.2

Table 19: Comparison of equivalent stresses on members

6.5.2 Aluminum 7005-T

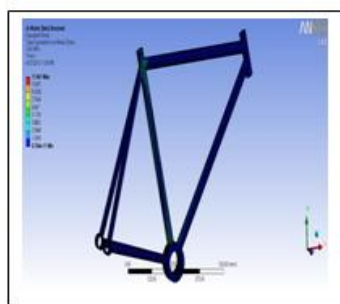

Figure 19: Equivalent stress, Static start up

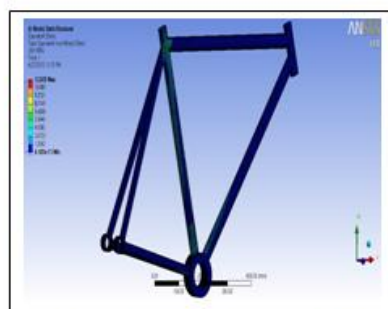

Figure 20: Equivalent stress, Steady state pedaling



Figure 21: Equivalent stress, Vertical impact



Figure 22: Equivalent stress, Horizontal impact

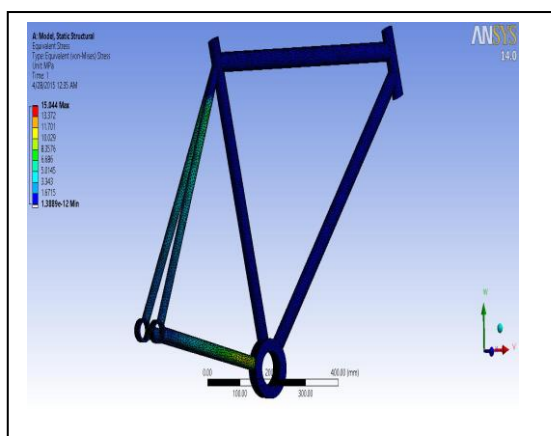

Figure 23: Equivalent stress, Rear wheel braking

Load case	Equivalent (von-Mises) Stress in members (MPa)				
	Top tube (AB)	Down tube (AD)	Seat tube (BD)	Seat stays (BC)	Chain stays (CD)
Static start up	10.34	0	11.64	9.05	0
Steady state pedaling	10.68	5.34	12.02	9.35	4.01
Vertical impact	20.69	12.93	23.28	18.1	2.58
Horizontal impact	32.42	28.81	0	0	0
Rear wheel braking	0	0	0	13.37	15.04

Table 20: Comparison of equivalent stresses on members

Comparison Of Maximum Stress Obtained For Different Cases

The maximum values of stresses obtained for the different loading cases for different alloys are compared in order to ascertain the properties of material alloy to take the impact of the loading (Table 20).

ALLOYS	Maximum stress obtained for different cases (Mpa)				
	Static start up	Steady state pedaling	Vertical impact	Horizontal impact	Rear wheel braking
Aluminum 6061-T	23.25	23.75	46.5	28.96	16.2
Aluminum 7005-T	11.64	12.02	23.28	32.42	15.04

Table 21: Comparison of maximum stress (MPa) obtained for different cases

Comparison Of Maximum Deformation Obtained For Different Cases

The maximum values of deformation obtained for the different loading cases for different alloys are compared in order to ascertain the properties of material alloy to take the impact of the loading. (Table 21).

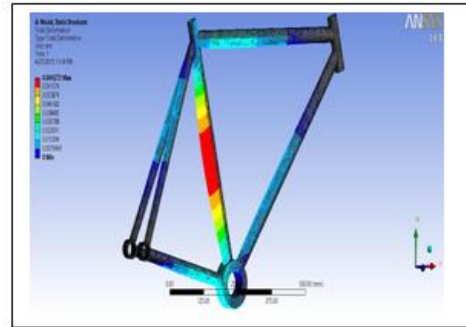
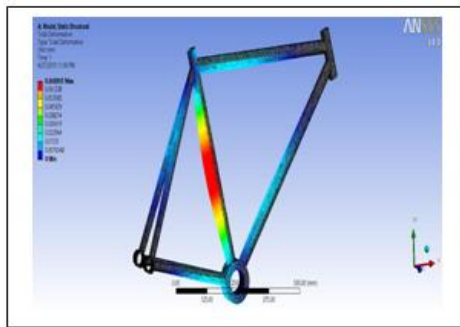

Figure 24: Static start up (maximum deformation) **Figure 25:** Steady state pedaling (maximum deformation)

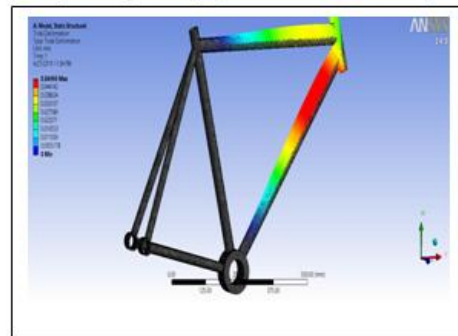
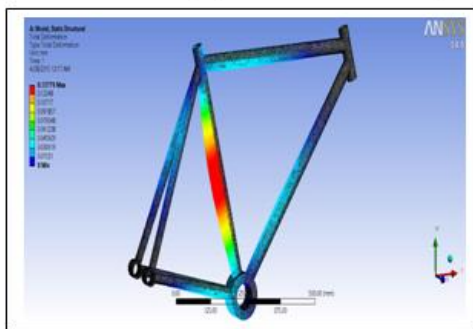

Figure 26: Vertical impact (maximum deformation) **Figure 27:** Horizontal impact (maximum deformation)



Figure 28: Rear wheel braking (maximum deformation), Aluminum 6061-T

ALLOYS	Maximum deformation obtained for different cases (mm)				
	Static start up	Steady state pedaling	Vertical impact	Horizontal impact	Rear wheel braking
Aluminum 6061-T	0.023	0.024	0.047	0.049	0.56
Aluminum 7005-T	0.068	0.069	0.137	0.05	0.54

Table 22: Comparison of maximum deformation (mm) obtained for different cases

- Aluminum 7005-T happens to be the most deformed alloy with a deformation of 0.068, 0.069, 0.137 and 0.05 mm for static start up, steady state pedaling, vertical impact and horizontal impact loading cases respectively.
- Aluminum 6061-T is the most deformed alloy for rear wheel braking loading case with a deformation of 0.56 mm.

Factor Of Safety

Factor of safety decides the structural capacity of a system beyond the expected loads or actual loads. Factor of safety is decided by the minimum value for any case of a particular alloy. The more the factor of safety the more is the chance of material alloy to bear the loading case.

Factor of Safety = Material Strength / Design Load

ALLOYS	Factor of safety obtained for different cases				
	Static start up	Steady pedaling state	Vertical impact	Horizontal impact	Rear wheel braking
Aluminum 6061-T	11.87	11.62	5.93	9.52	15
Aluminum 7005-T	15	15	14.5	9.77	15

Table 23: Factor of safety for different loading cases

The least factor of safety of 5.93 is for Aluminum 6061-T frame on the vertical impact loading case. The highest factor of safety happens to be for Titanium-6Al-4V frame where for each case it is 15. Here for all alloys the factor of safety happens to be above 2 which is a safe case for any designed model. It means that all the alloys can withstand the applied loads without any failure. Besides from Table 77 the increasing order of safety factor for alloys can be as follows:

Aluminum 6061-T < Aluminum 7005-T

IV. Modal Analysis

Vibration analysis is made to be performed on all the 5 material alloy frames. No boundary condition is applied on the bike frames. Seat tube is supported so as to make the bike frames stable for the vibration test. When the simulation has finished the mode shapes are made visible

Aluminum 6061-T



Figure 29: Mode 1, 235.78 Hz



Figure 30: Mode 2, 255.27 Hz



Figure 31: Mode 3, 301.66 Hz



Figure 32: Mode 4, 324.36 Hz

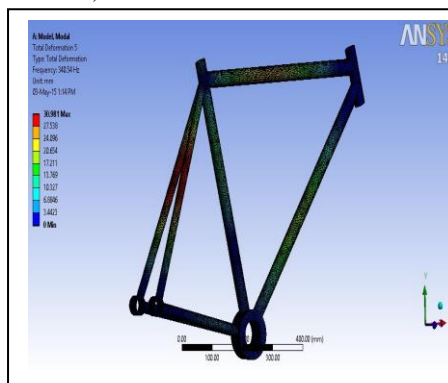

Figure 33: Mode 5, 340.54 Hz

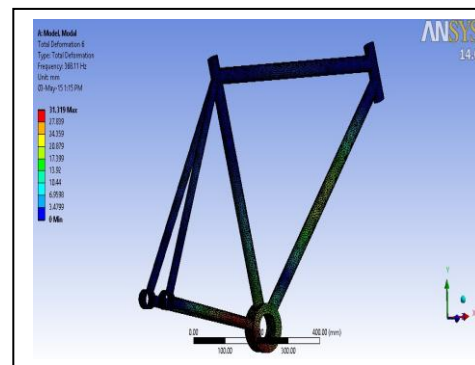

Figure 34: Mode 6, 368.11 Hz

6.9.2 Aluminum 7005-T



Figure 35: Mode 1, 235.86 Hz

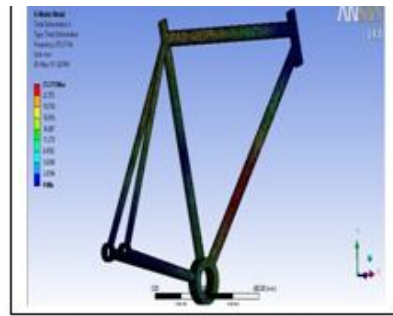

Figure 36: Mode 2, 255.37 Hz

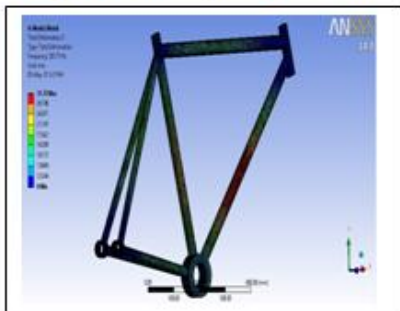

Figure 37: Mode 3, 301.71 Hz



Figure 38: Mode 4, 324.53 Hz

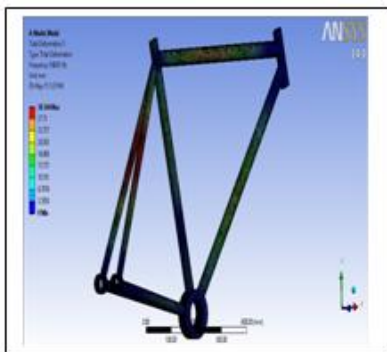

Figure 39: Mode 5, 340.61 Hz

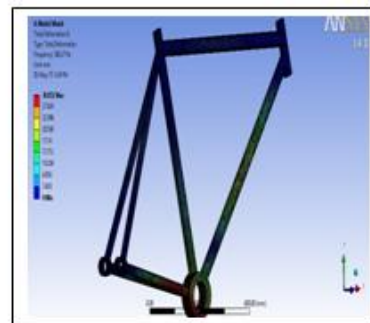

Figure 40: Mode 6, 368.27 Hz

ALLOYS	NATURAL FREQUENCY OF THE BIKE FRAMES (Hz)					
	MODE 1	MODE 2	MODE 3	MODE 4	MODE 5	MODE 6
Aluminum 6061-T	235.78	255.27	301.66	324.36	340.54	368.11
Aluminum 7005-T	235.86	255.37	301.71	324.53	340.61	368.27

Table 24: Comparison of natural frequencies of the bike frames (Hz)

The modal analysis clearly suggests the dynamic behavior of the bike frames on free vibration conditions. The mode shapes quantify the vibration pattern of the material alloy. The 1st mode shape obtained defines the 1st vibration obtained for the bike frame on free vibration. From Table 78 we can deduce the mode shape obtained for different alloys. The increasing order of frequency is as follows:

Aluminum 6061-T < Aluminum 7005-T

The increasing order of deformation can be made out from the figure (124-154) which is as follows:
Aluminum 7005-T < Aluminum 6061-T

Frame Weight

ALLOYS	FRAME WEIGHT (Kg)
ALUMINUM 6061-T	2.28
ALUMINUM 7005-T	2.52

Table 25: Comparison of frame weight (kg)

V. Conclusion

A mountain bike frame is designed with standard dimensions for a person with a height of 5 feet 10.75 inches. It has been designed for off road cycling. The dimensions of the frame are in accordance to the industry standards.

The design methodology was such chosen that the designer should have more control over outcome of results.

The inner and outer diameter of top tube, seat tube and down tube is 33 mm and 29 mm with a thickness of 2mm. The inner and outer diameter of seat stays and chain stays are 23 mm and 21 mm with a thickness of 1mm. The lengths of the tubes are taken in accordance to the rider’s height. The lengths are close to industry standard. Modeling of the designed bike frame is done in NX Unigraphics 7.5 software. The bike frame is designed in 2 different material alloys so as to analyze and compare the frame material according to one’s need. For these 2 frames, 5 different load cases are defined in order to make out the stress and deformation in each frame. Normal stress analysis along x-axis is also performed in ANSYS software with the same loading cases. The stresses obtained from both the theoretical (analytical) and ANSYS are compared and a difference of 0% to 42.6% is seen in the results but the average difference is around 5% which can validate the ANSYS results as there is difference in meshing standard in both the analysis.

Equivalent (von-Mises) stress analysis for all material alloys for all load cases is performed in ANSYS to make a comparative study. Results of all cases reveal that the maximum stress in the member of the bike frames is less than the yield strength in tension for the material selected. A comparative study is also made for the total deformation in the members of alloys for all load cases. Aluminum alloys are light weight but are easily deformed.

References

- [1]. Wu Chia-Chin, (2013), Static and dynamic analyses of mountain bikes and their riders. PhD thesis, University of Glasgow, UK, 2013.
- [2]. Arola D, Reinhall PG, Jenkins MG, Iverson SC. 1999. An experimental analysis of a hybrid bicycle frame. *Exp Tech*. May/June: 21–24.
- [3]. Derek Covill and Steven Begg, 2014, parametric finite element analysis of bicycle frames geometries, a School of Computing, Engineering and Mathematics, University of Brighton, Lewes Rd, Brighton, BN2 4GJ, UK.
- [4]. J. Enright. Simulation of Mountain Bike Dynamics. Industrial Project Report, Department of Mechanical Engineering, University of Glasgow, UK, 2007.
- [6]. Fabian Fuerle, Johann Sienz, “Decomposed surrogate based optimization of carbon-fiber bicycle frames using Optimum Latin Hypercubes for constrained design spaces”, Elsevier Ltd. Vol.-119, 2013, pp. 48–59.
- [7]. Forest Dwyer, (2012), Material and Design Optimization for an Aluminum Bike Frame, WORCESTER POLYTECHNIC INSTITUTE.
- [8]. Joachim Vanwalleghem, Wim Van Paepegem, Mia Loccufier, Ives De Baere Damping and vibration behaviour of flax-carbon composite bicycle racing frames, Materials Science and Engineering Department, Ghent University (UGent),Gent, Belgium, Joachim.Vanwalleghem.
- [9]. Lessard, L., Nemes, J., Lizotte, P. 1995. Utilization of FEA in the design of composite bicycle. *Composites*, 26(1), 72-74.
- [10]. M. Levy and G.A. Smith. Effectiveness of Vibration Damping with Bicycle Suspension Systems. *Sports Engineering*, Vol., 8, No. 2, pp. 99-106, 2005.
- [11]. Liu, T., Wu, H. 2010. Fiber direction and stacking sequence design for bicycle frame made of carbon/epoxy composite laminate. *Materials and Design*, 31(4), 1971–1980.