

Vibrations of a mechanical system with inertial and forced disturbance

Boris Petkov, PhD

(Department of Material Handling and Construction Machines, University of Transport "T. Kableshkov", Sofia, Bulgaria)

Abstract: We present a mechanical system model of the inertial type vibrocompactor used in railroad building. In the paper we examine forced vibrations of the mechanical system excited by inertial disturbance. Using a dynamical model of the mechanical system and applying numerical methods, frequency response and frequency relations are found.

Keywords: vibrocompactor, dynamical model, frequency response, inertial forced vibrations.

I. Introduction

Vibrocompacting of bulk materials is widely used in the construction, repair, and maintenance of automobile and rail-roads. This ensures that the road's overlays are dense enough for the needed strength of the road.

Vibrocompacting is a dynamic process that creates a specific level of density of the bulk materials through regulating the different parameters — frequency, amplitude, and force/pressure.

The dynamical modelling of the vibrating machine of inertial type enables to study working regimes depending on different frequencies of disturbance action.

The results of the study of the dynamical model are vital in the construction of vibrocompactors.

II. Dynamical model

The inertial vibrocompactor can be represented as a two-mass system (Fig. 1) with two degrees of freedom, that performs forced oscillations generated by an inertial disturbance [1]. The parameters of the system are focused — it has been assumed that the motion is only along one of the principal axes.

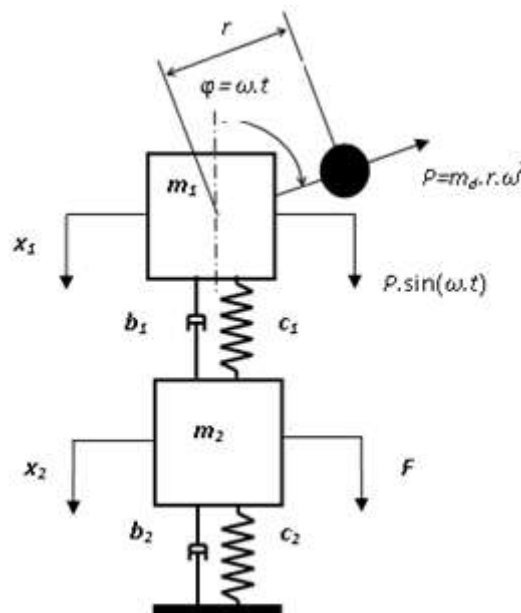

Fig.1. Dynamical model of a vibrocompactor of inertial type

The second kind Lagrange equation is used to describe the forced fluctuations from the stable state of the mechanical system in the presence of potential and dissipative forces.

The system of differential equations, describing the model, follows:

$$\mathbf{M}\ddot{\mathbf{x}} + \mathbf{B}\dot{\mathbf{x}} + \mathbf{C}\mathbf{x} = \mathbf{z} \quad (1)$$

where:

$$(M) = \begin{pmatrix} m_1 & 0 \\ 0 & m_2 \end{pmatrix} \quad (B) = \begin{pmatrix} b_1 + b_2 & -b_2 \\ -b_2 & b_2 \end{pmatrix} \quad (C) = \begin{pmatrix} c_1 + c_2 & -c_2 \\ -c_2 & c_2 \end{pmatrix} \quad \bar{z} = \begin{bmatrix} P \sin \omega t \\ F \end{bmatrix}$$

III. Natural frequencies and frequency response

1. The natural frequencies are determined for the free vibrations of the undamped system [2]:

$$M\ddot{x} + C\dot{x} = 0 \tag{2}$$

The harmonic solutions for x mean that it has the form $x = X \sin \omega t$ and substitution into the equation of motion (2) gives:

$$(-\omega^2 M + C)X = 0 \tag{3}$$

The natural frequencies are found by solving the eigenvalue problem:

$$\det[C - \lambda M] = 0, \text{ where } \lambda = \omega^2 (\lambda > 0, \lambda \in R). \tag{4}$$

The natural frequencies follow as $\omega_i = \sqrt{\lambda_i}$.

Using MATLAB and the values of the parameters listed in the appendix, the following natural frequencies are calculated:

$$\omega_1 = 138.8 \text{ s}^{-1} \text{ and } \omega_2 = 929.5 \text{ s}^{-1}.$$

2. Frequency response is determined for the forced damped system [2] after a Laplace transformation of equation (1) has been performed:

$$(Ms^2 + Bs + C)X(s) = z(s) \text{ or } X(s) = [Ms^2 + Bs + C]^{-1} z(s), \text{ where } s = i\omega \text{ and therefore:}$$

$$X(i\omega) = [-\omega^2 M + i\omega B + C]^{-1} z(i\omega) \tag{5}$$

The frequency response function (fig.2) is built using (5) in MATLAB.

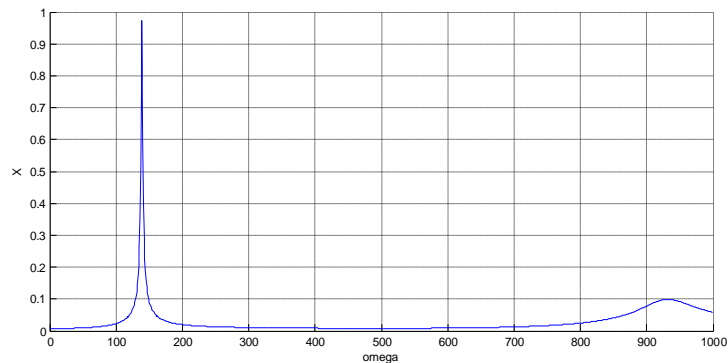

Fig.2 Frequency response of the damped system

IV. Numerical analysis

We show the numerical analysis of the system for four cases: free vibrations ($\omega = 0$), dynamic multiplication ($\omega = \omega_1, \omega = \omega_2$), beating regime (ω is close to ω_1) and regime with frequency inbetween natural frequencies [3].

The numerical solutions are found in MATLAB (see the values of machine's parameters are in the appendix).

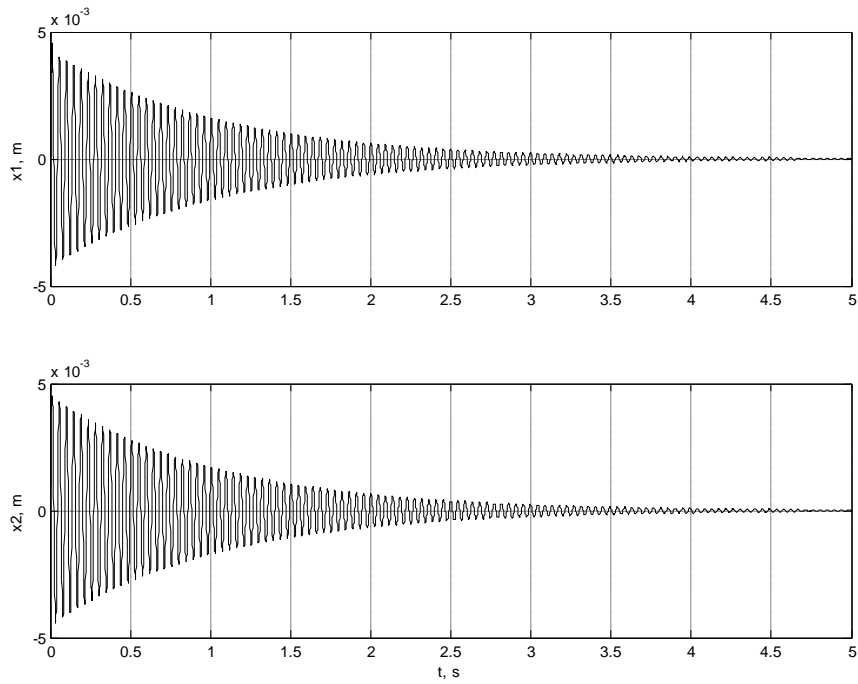

Fig.3 Free Vibrations at $\omega = 0$

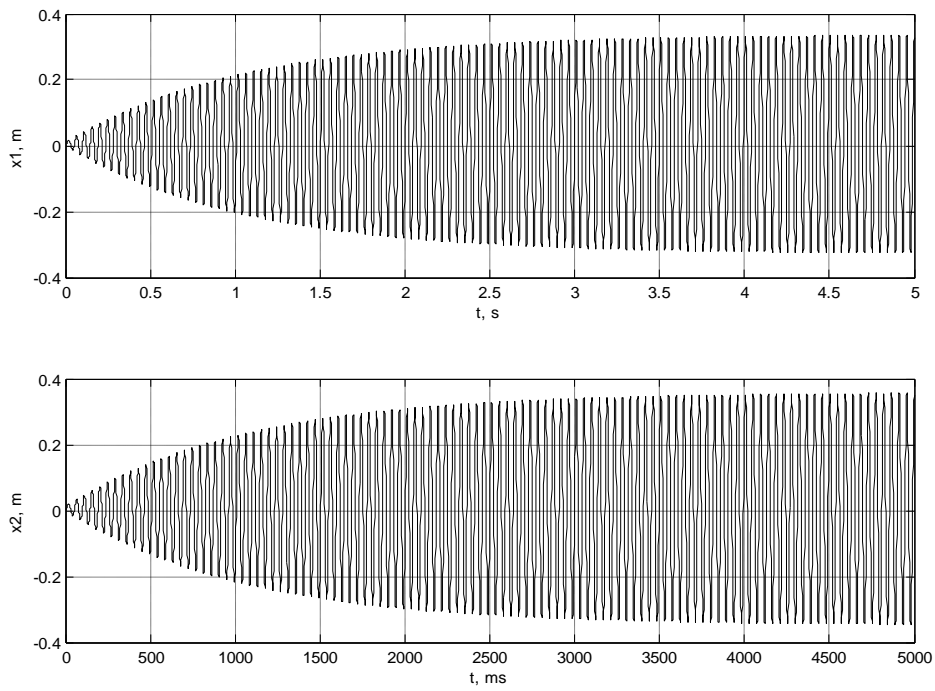

Fig.4 Forced Vibrations at $\omega = \omega_1 = 138,8 s^{-1}$

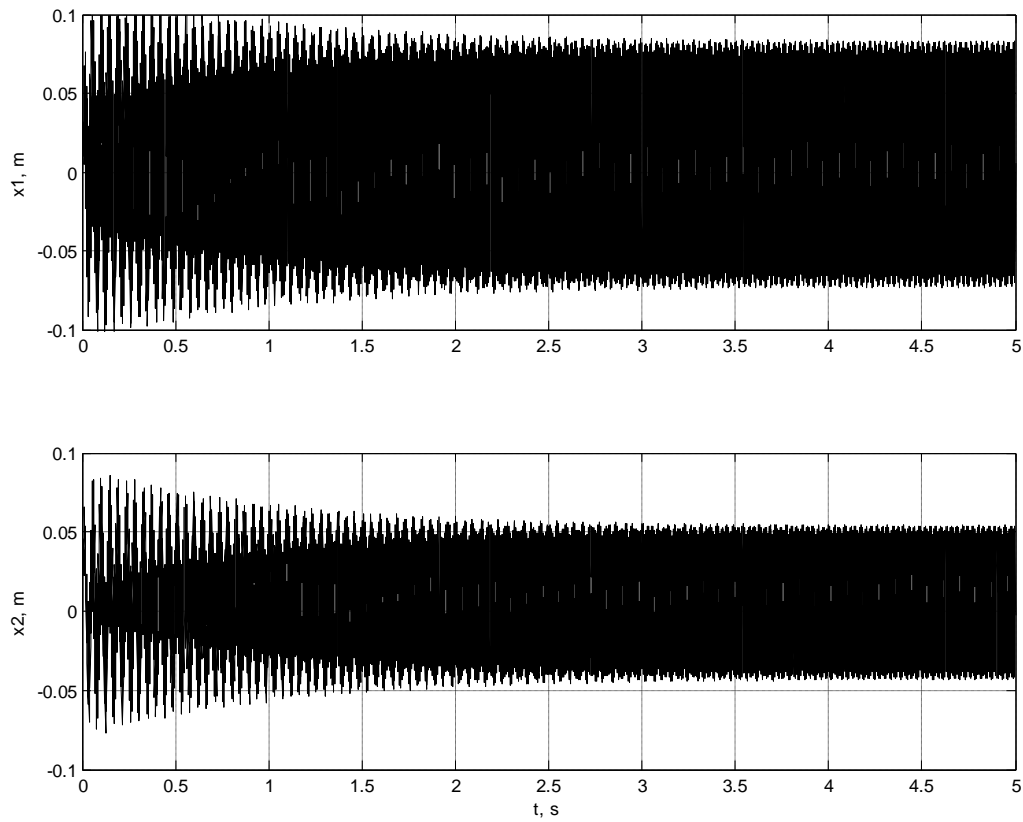

Fig.5 Forced Vibrations at $\omega = \omega_2 = 929,5 \text{ s}^{-1}$

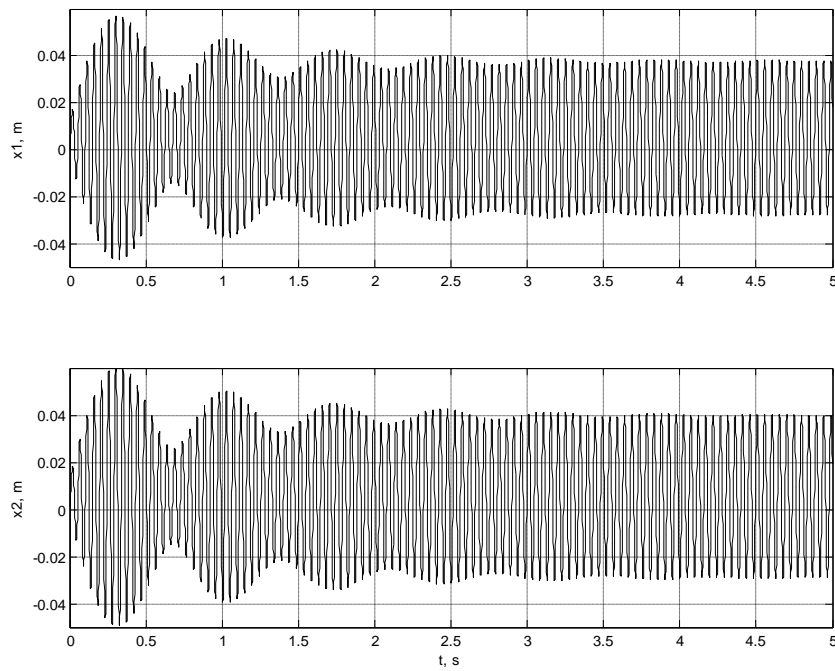

Fig.6 Forced Vibrations at $\omega = 130 \text{ s}^{-1}$ (close to ω_1)

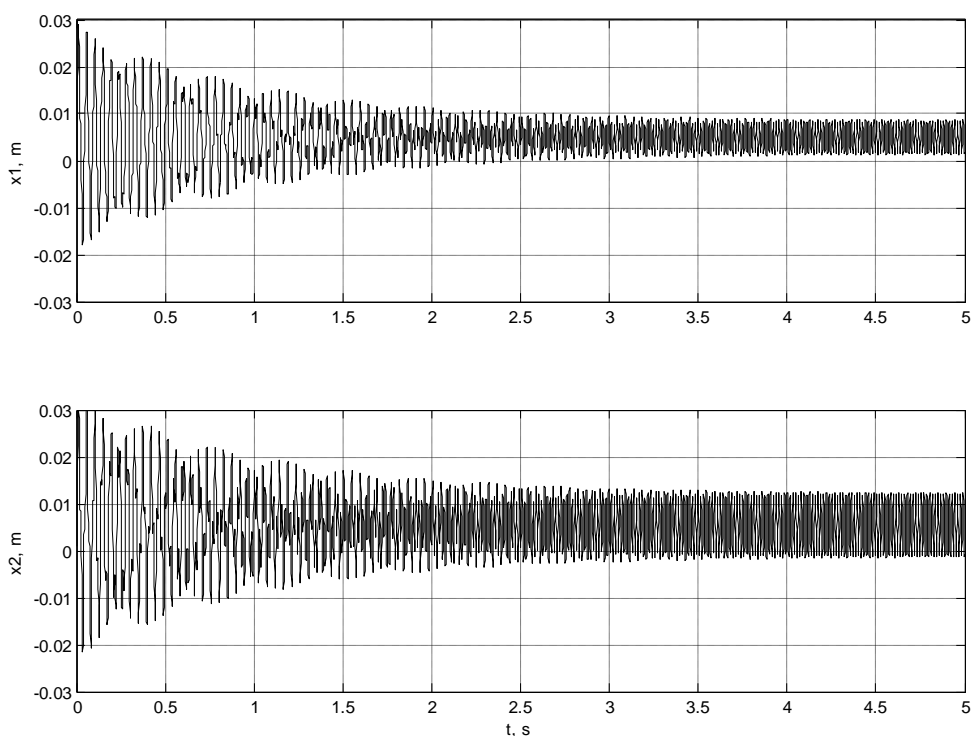

Fig.7 Forced Vibrations at $\omega = 400 \text{ s}^{-1}$

In all cases, during the stationary regime, there are steady harmonic vibrations. At frequencies 130 s^{-1} and 400 s^{-1} (fig. 6, fig. 7) the non-stationary processes are poly harmonic due to the beat on both coordinates x_1 and x_2 .

V. Conclusions

The examination of vibrations of the inertial type vibrocompactor prove that the machine can work steady and properly inside a wide range of frequencies except these ones in the area near the first natural frequency where the beat breaks up steady work in non-stationary regimes.

Such examination could take part in the process of constructing of new machines or improve the performance of the existing ones.

Appendix

Parameter	Value	dimension	Parameter	Value	dimension
Mass of vibrator incl. unbalanced mass – m_1	40	kg	Damping coefficient of the gravel – b_2	1900	Ns/m
Mass of the tampers – m_2	60	kg	Damping coefficient of the suspension – b_1	200	Ns/m
Stiffness coefficient of the suspension – c_1	$2 \cdot 10^6$	N/m	Force - F	10	kN
Stiffness coefficient of the gravel – c_2	$21 \cdot 10^6$	N/m	Radius of the unbalanced mass - r	0.05	m

References

- [1]. B. Petkov, Dynamic model of vibrocompactor with two degrees of freedom, *Mechanics, Transport, Communications:3-2015*.
- [2]. Тондл А., *Нелинейные колебания механических систем*, (Мир, Москва, 1978)
- [3]. D. Vasilev, Vibrations of a mechanical system with positional dry friction and kinematics and forced disturbance, *Mechanics, Transport, Communications:3-2015*.