

Analysis and development of Yoke for Medium duty Automobile Vehicle Using Finite Element analysis

S. P. Chaphalkar¹, Subhash. N. Khetre², Arun M. Meshram³

¹ Head of Department, Department of Automobile Engineering, Pimpri Chinchwad, Polytechnic, Pune

² Lecturer, Department of Mechanical Engineering, RSCOE, (II-Shift) Polytechnic, Tathawade, Pune

³ Lecturer, Department of Mechanical Engineering, RSCOE, (II-Shift) Polytechnic, Tathawade, Pune
Maharashtra (India)

Abstract : The aim of this study is to examine the effects of varying thickness of yoke and lording conditions. The yoke in a door system are one of the main parts of an automobile. It is a very important part to attain stability and steady movement of the vehicle doors. It consists of two yokes, connected by intermediate door system of vehicles consist several components which sometimes encounter unfortunate failures. Some common reasons for the failures may be manufacturing and design faults, maintenance faults, raw material faults, material processing faults as well as the user originated faults. In this paper finite element analysis of the component is carried out to find the stress and deformation of the final product. For modeling of the component, Pro-Engineers software is used. Preprocessing work like meshing and analysis work is carried out in HYPERWORKS software. Yoke have certain modification are made in existing geometry and analyzing for the identical boundary condition. Thus in this paper the aim is to analyze thickness with same material. Using FEA analysis, we can identify the nature and characteristics of stresses acting on the yoke.

Keywords: Universal joint Yoke, chain link, Structural analysis, Finite Element analysis, Stress Analysis.

I. Introduction

The purpose of this design work was to improve upon an existing design for use in Automobile. Yoke joint is a device used to connect rotating shafts that are coplanar, but not coinciding. Each yoke joint assembly consists of three major components: two yokes (flange and weld) and a cross. An automotive yoke has a machined flat face which may be affixed through a bolted connection to the front door and rear door of a vehicle. A weld yoke incorporates a machined step, and is inserted into the end of the yoke shaft and welded in place. Yoke design should be performed as part normal vehicle and recognition of component is necessary to prevent serious mechanical problems as well as driver discomfort. Failure to perform normal maintenance may also avoid the yoke failures can result from improper maintenance, installation or assembly procedures. This quick reference guide assists service technicians in recognizing component failures and identifying probable causes. So, check the output and input end yokes for looseness, excessive radial looseness, looseness across ends of yoke joint, the shaft for damage, bent tubing or missing balance weights. When design yoke specify the following ordering data: Design required, Size required, Material required, Design conditions - both pressure and temperature, Application - horizontal or vertical, Corrosion allowance if applicable. Modern literature indicates that substantial effort continues to be put forth to understand the spastics and dynamics of a yoke joint. Yoke joint design for automotive applications is considered extensively in a comprehensive text compiled by the Society of Automotive Engineers in [1], and offers valuable insight into common design practices and guidelines. The term 'optimization' is often used to describe the process of finding improved solutions. However, without a formal statement of objective functions, performance measures, constraints and design variables, the selection of the 'best' design may be subjective. S. K. Chandole [3], conducted optimization on a universal joint with manufacturing tolerances by using process flow diagrams, but did not employ gradient-based search techniques to analytically map the design space. Optimization of multiple performance measures requires a multi-objective weighting.

Failure Analysis of an Automotive Component (Cardan Yoke) by Scanning Electron Microscopy, A. A. Couto, A. H. P. Andrade[5], studied that failure analysis of two card an yokes that fractured during the straightening operation revealed that due to bending stresses, the rupture initiated at the edges of the component from circumferential cracks. The fracture mode was predominantly intergranular, indicating that the component was in a brittle state. In the failed region, the hardness was higher than the specified value. This was due to segregation, which resulted in a microstructure consisting of superimposed martensite layers (banding). Failure analysis and optimization in yoke assembly subjected by torsion and shear, P. G. Tathe, Prof. D. S. Bajaj [1], Studied that yoke assemblies are one of the most important parts in propeller shaft. In this study, failure analysis of a universal joint yoke of an automobile power transmission system is carried out. Continues variable torque (Torsion) loading & shearing are important mode failure having high risk priority number. Scope of the study is

linear static structural stress analysis is carried out by using the following software tools: Hyper Mesh, ANSYS, Abaqus, or any compatible CAE software in the 'Structural' domain. In experimental method physical testing is carried out by using strain gauge technique. In the highest stresses of yoke crack will occur after a crack propagation period the component had completely fractured.

II. Objectives

The following are main objective of yoke design.

1. A detailed understanding of function and configuration of yoke
2. To design & development of yoke mechanism
3. To Analysis of yoke using FEA.
4. To check at how many layers thickness fails by failure criteria.

III. Research methodology

In this work it is proposed to design and development of yoke using FEA for door system for medium duty vehicles. The said work is planned in following phases.

1. Review of literature regarding the work done.
2. Design of yoke.
3. Analysis of Structural steel yoke.
 - To develop yoke model using *Pro-Engineers*.
 - Meshing of yoke
 - Apply Boundary Conditions and Loading
4. Manufacturing and assembly of yoke.
5. Result and Discussions.
6. Concluding remark.

IV. Material Selection

Material is selected based on properties such as high bending & tensile strength, ease of availability, ease of machining, welding, finishing, cutting etc. and cost factor. Component number 1, 2, 3, 4, 5, 6 and 7 will use the structural steel. Mechanical properties of structural steel are given in Table-1 below:

Table 1: Mechanical properties of Structural Steel

Sr. No	Type of Structural Steel	Values
1	Young's Modulus (Pa)	2.e+011
2	Poisson's Ratio	0.3
3	Density	7850 kg m ⁻³
4	Tensile Yield Strength (Pa)	2.5e+008
5	Tensile Ultimate Strength (Pa)	4.6e+008
6	Bulk Modulus (Pa)	1.6667e+011
7	Shear Modulus (Pa)	7.6923e+010

V. Finite element Analysis of yoke:

The finite element method is a numerical procedure for analyzing structures and continua. Usually problem addressed is too complicated to solve satisfactorily by classical analytical methods. The finite element procedure develops many simultaneous algebraic equations, which are generated and solved on a digital computer. The results obtainable are accurate enough for engineering purposes at reasonable cost. In addition it is an efficient design tool by which designers can perform parametric design studies by considering various design cases (different shapes, materials, loads etc.) analyze them and choose the optimum design . Hence the method has increasingly gained popularity among both researchers and practitioners.

5.1 General description of finite element analysis:

In the finite element method, the actual continuum or body of matter like solid, liquid or gas is represented as on assemblage of sub divisions called finite elements. These elements are considered to be interconnected at specified joints, which are called nodes or nodal points. The nodes usually lie on the element boundaries where adjacent elements are considered to be connected. Since the actual variation of the field variable (like displacement, stress, temperature, pressure and velocity) inside the continuum is not known, we assume that the variation of field variable inside a finite element can be approximated by a simple function. By solving the field equations, which are generally in the form of matrix equations, the nodal values of the field variable will be known. Once these are known, the approximating function defines the field variable throughout the assemblage of elements.

5.2 Basic steps of finite element analysis:

There are three basic steps involved in this procedure

1. Pre Processor (Building the model (or) Modeling)
2. Solution (Applying loads and solving)
3. Post Processor (Reviewing the results)

The model of yoke that is analyzed in the reference paper has its mounting base a plain surface with a central hole. A chamfer was provided on the inner hole at the base of the yoke where it is mounted to the door system. The original model has the region joining the main body of the yoke with the base as a sharp edge structure as shown in the Fig 1. In the modified model, a fillet of radius 3.5 mm is also provided in addition to the chamfer. The model with added fillet is shown in the figure below.

5.3. Boundary Conditions:

The meshed model is then analyzed (static) and the boundary conditions are:

- One end is fixed (All DOF).
- A moment of 18 N-m is applied at the other end.

5.4. FEA results obtained are discussed below:

The following are the results for yoke and shaft hole with different thickness of the yoke.

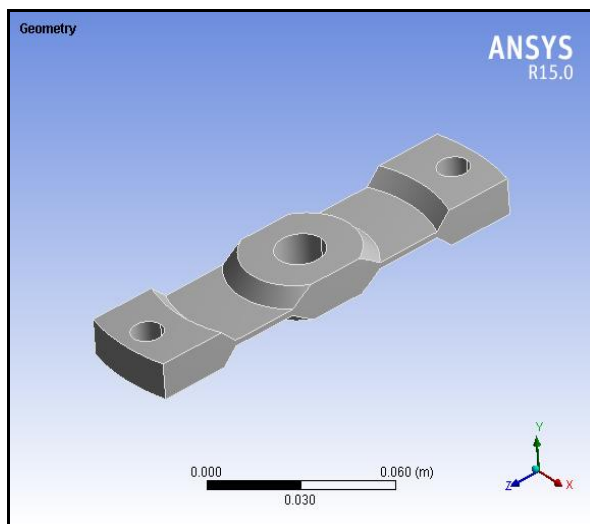

Fig. 1 : Geometry of Yoke

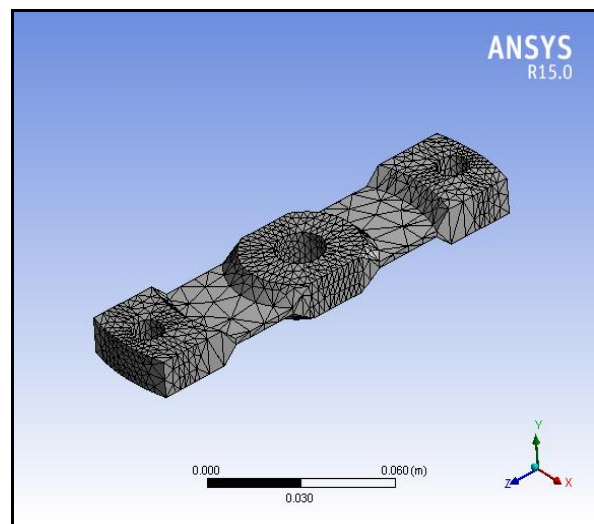

Fig. 2 : Meshing of Yoke

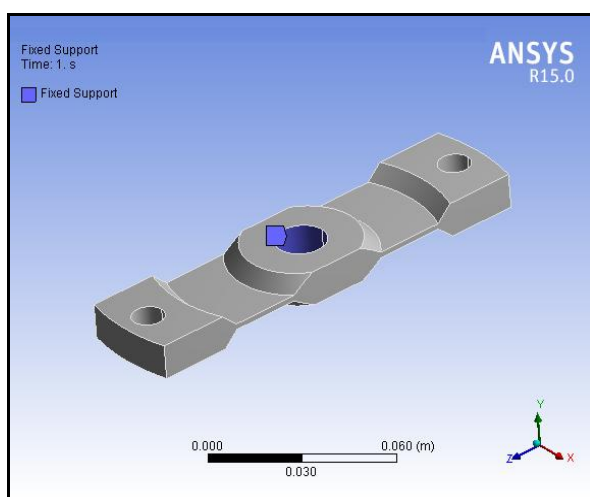

Fig. 3 : Fixed Support of Yoke

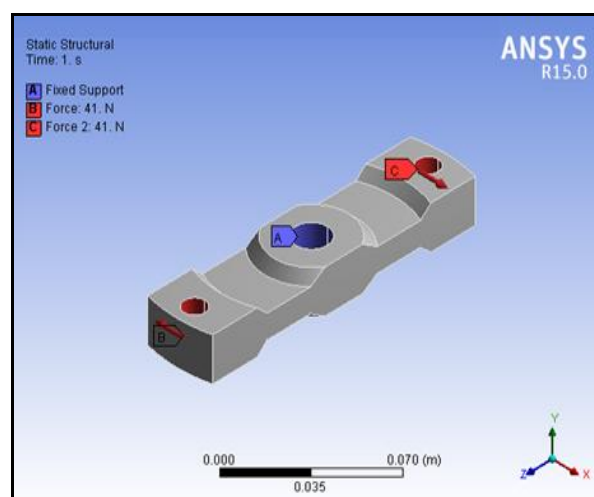

Fig. 4 : Boundary Condition of Yoke

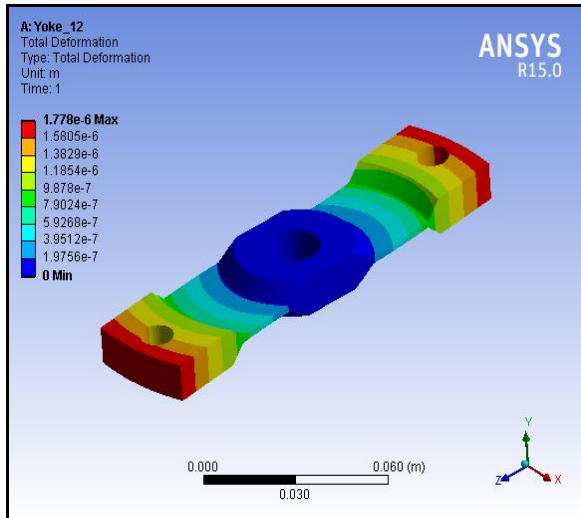

Fig. 5(A) : Equivalent Stress Yoke 12mm thickness

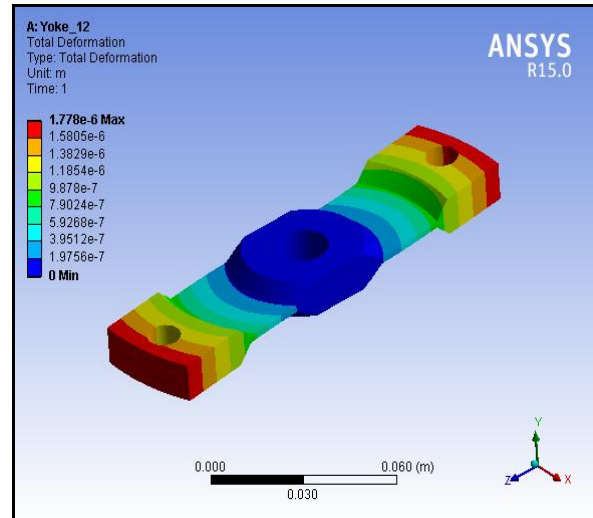

Fig. 5(B) : Total Deformation Yoke 12mm thickness

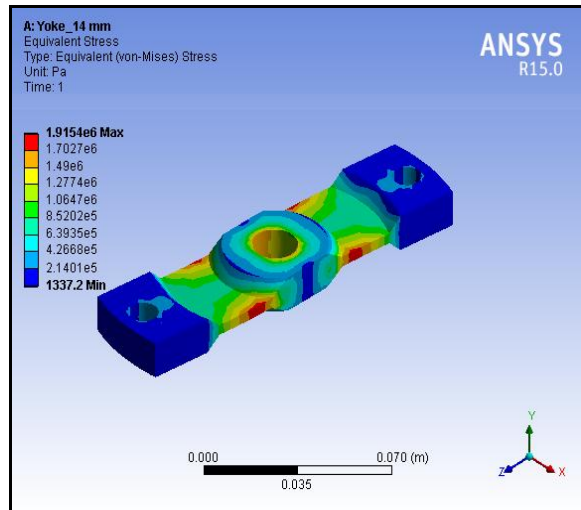

Fig. 6(A) : Equivalent Stress Yoke 14mm thickness

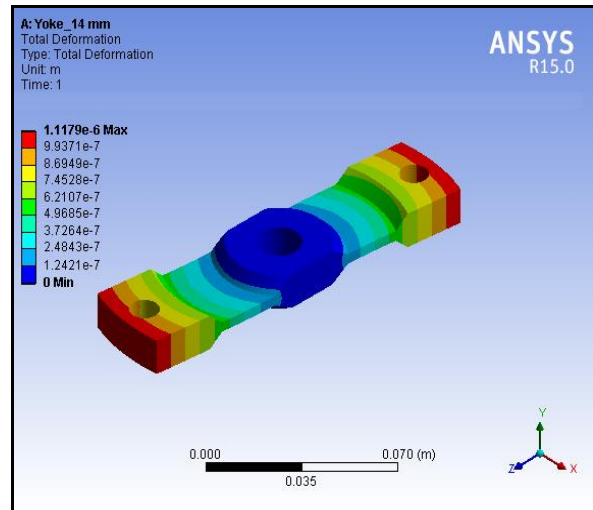

Fig. 6(B) : Total Deformation Yoke 14mm thickness

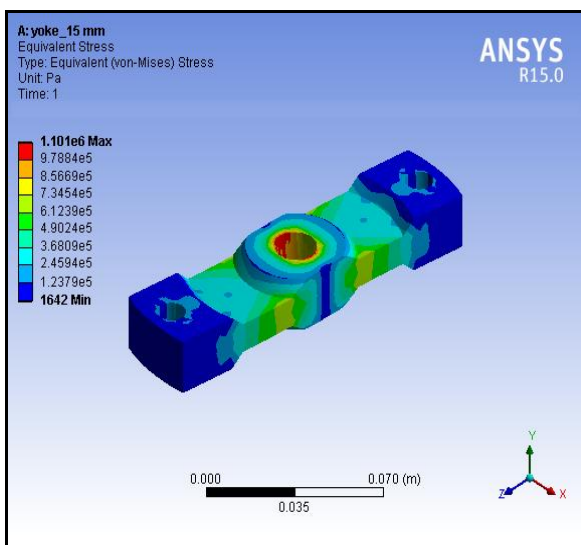

Fig. 7(A) : Equivalent Stress Yoke 15mm thickness

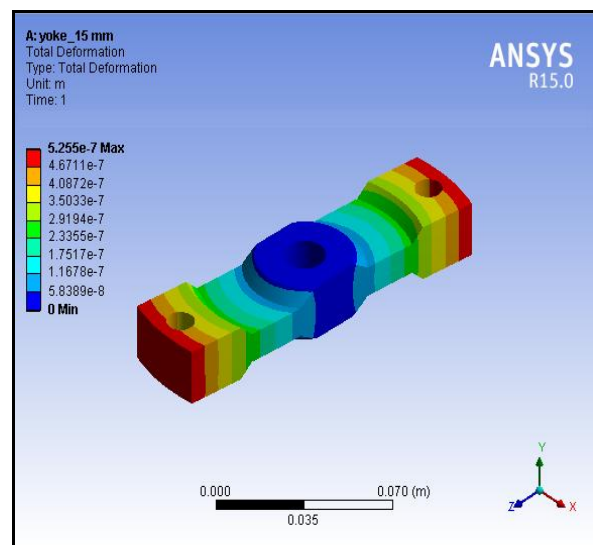

Fig. 7(B) : Total Deformation Yoke 15mm thickness

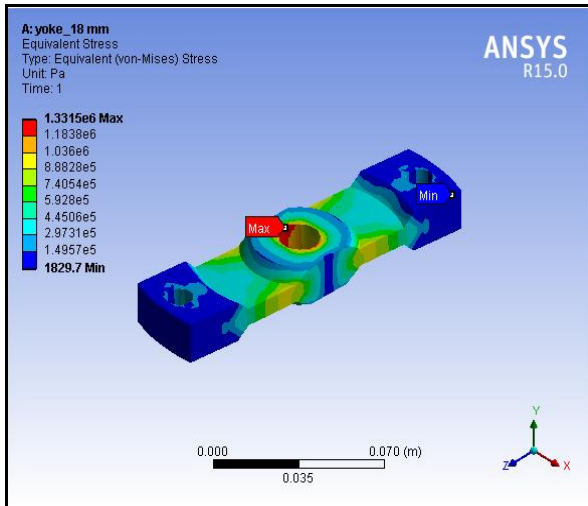

Fig. 8(A) :Equivalent Stress Yoke 18mm thickness

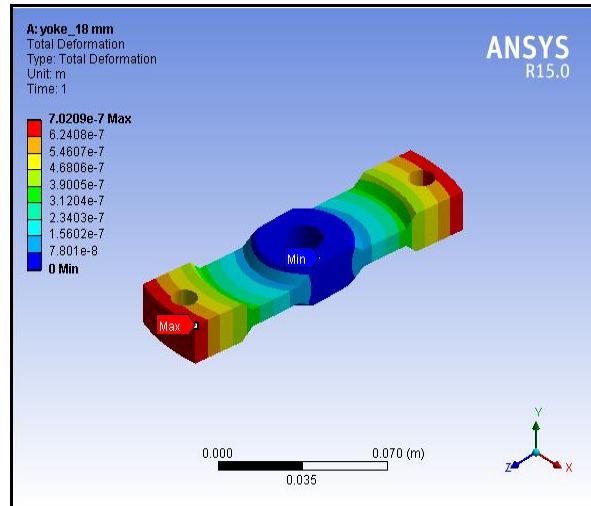

Fig. 8(B) :Total Deformation Yoke 18mm thickness

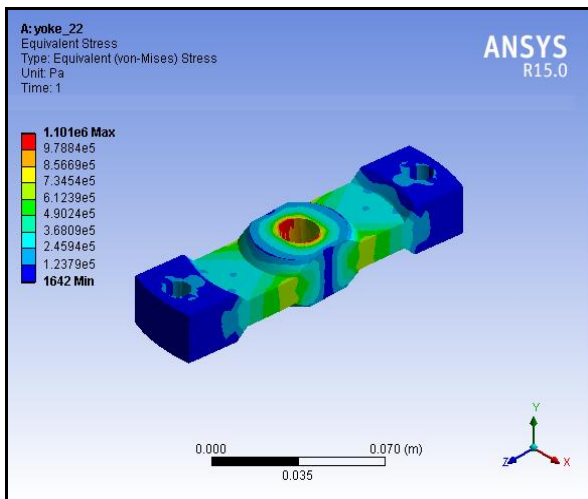

Fig. 9(A) Equivalent Stress Yoke 22mm thickness

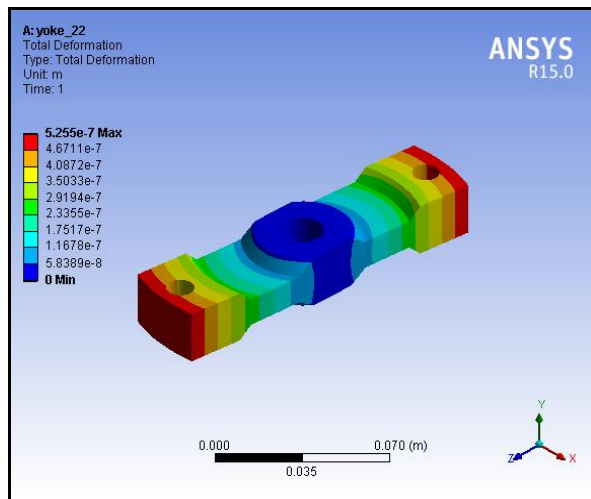

Fig. 9(B) Total Deformation Yoke 22mm

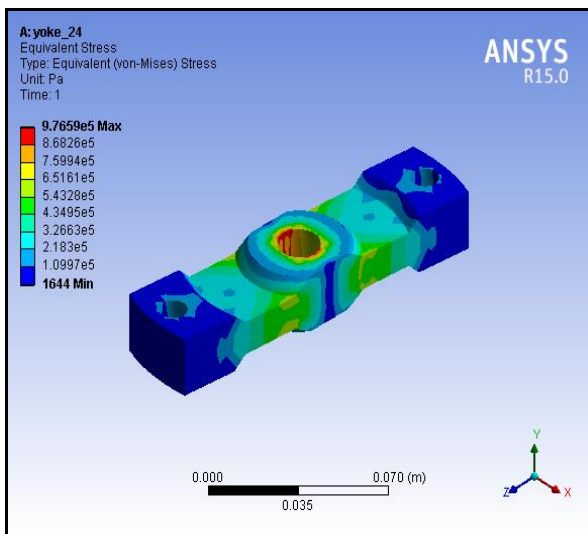

Fig. 10(A) :Equivalent Stress Yoke 24mm thickness

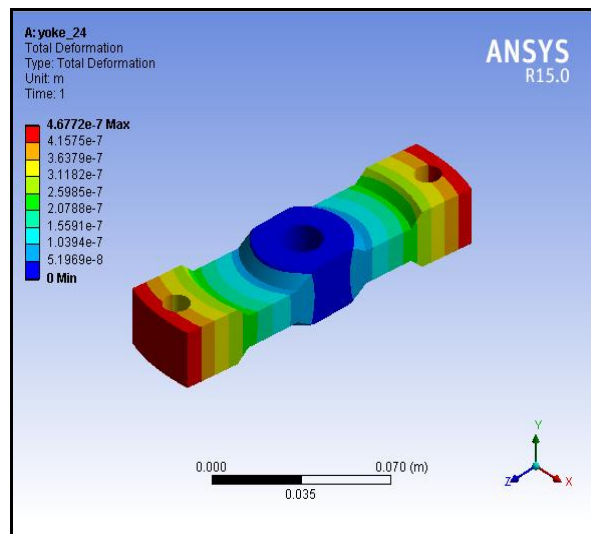

Fig. 10(B):Total Deformation Yoke 24mm thickness

VI. Summary of result

The summary of analysis of result summarized as show in table 2. The Static stress analysis is applied to calculation, which address the static analysis and total deformation analysis resulting. The purpose of static analysis is to insure safety of the yoke and supporting structure.



Fig. 11: Design of Yoke 18mm thickness for testing

Sustained loads are by using self weight and operating conditions. The analysis, the Pro-Engineers-CREO 2.0 and ANSYS 15.0 is used the analysis is carried out in two load steps, so here we taken thickness 18 mm as per necessary result to insure safety of the yoke and Stress (σ): The highest calculated stress will be in the order of 1.331512 N/m².

Table 2: Summary of FEA result of yoke

Sr. No	Thickness (mm)	Deformation (mm)	Stress (Max) (N/m ²)
1	12	0.000001778	3.774543
2	14	0.0000011179	1.915179
3	15	0.000000525	1.101321
4	18	0.000000702	1.331512
5	20	0.0000005999	1.196457
6	22	0.0000005255	1.101789
7	24	0.0000004677	0.976614

VII. Conclusion

We studied the analytical behavior of the yoke under the tensile loading condition and observed that there is stress concentration near to elliptical hole in the yoke, so the yoke will fail in that region. The design for the yoke would be subjected to F.E Analysis to find the effect of loads on the yoke. The proposed method utilizes software in the FEA domain for analyzing the effects of the variation in the values of the design parameters influencing the performance criterion. As the thickness decreases, other dimension would remain constant. It is observed that the optimal value of thickness is between 12mm to 24mm. though this optimization seems insignificant on its own, it must be noted that in a typical industrial application, thousands of such design will be needed.

The weight saving thus achieved will have a significant impact on cost of the yoke and more importantly with a lighter yoke, the cost savings during operation will also be significant. The yoke is concept in analysis of yoke thickness for medium duty Automobile vehicles industries is development research with different input speed to very output speed to give the more efficient in output operation.

VIII. Future Scope

The work has focused on study of existing model. All the measurement have been taken and detail like torsional strength, buckling strength and bending natural frequency have been improved by using this approach. Using different material we will find out the weight reduction of existing material. The main purpose of this paper is to improve the existing design and weight reduction of yoke with improving mechanical properties.

Acknowledgements

We gratefully acknowledge department of automobile engineering of Pimpri Chinchwad Polytechnic, Nigadi, Pune (India), for technical support and providing the research facilities. Their help and dedication toward our work and related research, also our friends for their directly & indirectly help, support and excellent co-operation.

References

Journal Papers:

- [1] P. G. Tathe, Prof. D. S. Bajaj, Failure analysis and optimization in yoke assembly subjected by torsion and shear, International Journal of Advanced Engineering Research and Studies, July-Sept 2014;3(4):13-15.
- [2] S. K. Chandole, M. D. Shende, Structural analysis of steering yoke of an automobile for withstanding torsion / shear loads, International Journal of Research in Engineering and Technology, Mar-2014;03(03):535-539.
- [3] Konstantin Ivanovo, A CAD Design of a New Planetary Gear Transmission, International Journal Of Innovative Technology and Research, 2014; 4(2):1063-1067.
- [4] Ranbir Singh, a brief review of transmission in automobiles, International Journal of Latest Research in Science and Technology, 2012; 1(2) :222-226
- [5] A.A. Couto, A.H.P. Andrade, Failure Analysis of an Automotive Component (Cardan Yoke) by Scanning Electron Microscopy, Trans Tech Publications, Switzerland, 2012; 326(328):187-192.
- [6] Amjad M. Abood, A Novel Cam-Based Infinitely Variable Transmission, Journal Of K Erbala University, 2010; 8(4): 61-74
- [7] F.A. Fitz, P.B. Pires, A geared infinitely variable transmission for automotive applications, SAE paper No. 910407, 1991:1-7
- [8] E. Faulring, The cobotic hand controller: Design, control and analysis of a novel haptic display, Ph.D. Dissertation, Northwestern University, 2005.
- [9] F.G. Benitez, J.M. Madrigal, J.M. del Castillo, Infinitely variable transmission of Ratcheting drive type based on one-way clutches, Journal of Mechanical Design, July 2004; 126:.673-682.
- [10] S. Matsumoto, N. Inoue, Y. Tsukada, Continuously variable transmission for Bicycles, United States Patent Application 20030221892, 2003.