

## Optimization and Control of Welding Distortion in Hatch Cover Girders

K.T. B. Padal<sup>1</sup> and K. Ajay Kumar<sup>1</sup>

Department of Mechanical Engineering , Andhra University College of Engineering (A) Visakhapatnam -530 003, A.P, India.

---

**Abstract:** An in-process method for controlling welding distortion in Hatch Cover Girders due to fillet welds is developed. It particularly reduces linear and angular distortion by performing FAIRING (triangular heating and triangular cooling) after the weld process. Various heating conditions are examined by experiment and by the lab test analysis (Geographic information system) in order to determine appropriate conditions and to study the mechanism by which welding distortion is reduced. It is consequently found that this mechanism is a result of two main effects: triangular heating effect on one side and triangular cooling effect on other side, which produces the opposite linear and angular distortion.

**Keywords:** weld distortion, in-process control, thermal elastic-plastic analysis, numerical computation, residual stress, real-time measurement

---

### I. Introduction

Evaluating welding distortion and residual stress is important in order to assure material weld ability, structural fabric ability, and structural integrity. In particular, prediction of welding distortion and its reduction are essential in order to control dimensions and reduce the fabrication cost of welded structures. Therefore, from the viewpoint of manufacturing efficiency, in-process control of welding distortion is more desirable than post-welding rectification or other methods. There are many methods for predicting welding distortion and residual stress, and they are useful for developing an in-process method for controlling weld distortion and residual stress. Thermal Lab test analysis with large-scale numerical computation is one of the most powerful tools for predicting the mechanical behavior of welding. The two-dimensional approach for calculating weld distortion and residual stress has been successfully achieved, and three-dimensional calculations have even recently been performed on the latest high-speed computers. Welding distortion and residual stress can be calculated under various welding conditions and for various configurations of welded structures by the thermal analysis, but a long computing time is required. As the other method, a simplified analysis using the principle of Eigen strain can rapidly estimate residual stress and distortion, once welding conditions have been determined. Simplified predicting equations of residual stress and welding distortion from pigeonholing experimental measurements are also often used. The most suitable method should be applied for studying in-process control of welding distortion and residual stress.

Methods using mechanical pre-straining, cooling, optimizing the welding sequence or using vibration has been developed for residual stress control in welding. The resulting reduction mechanism of residual stress has been verified and validated mainly by numerical analysis. In-process control of weld distortion is performed by using restraint, elastic prestraining, preheating, preheating or/and stretching, or heat control by cooling. These methods have been applied to actual welded structures, but the reduction mechanism of welding distortion has not been completely studied because most of these techniques were only experientially established for specific conditions.

A mechanical method for in-process control of weld distortion such as restraint needs huge force and equipment for actual components. The easiest way to reduce welding distortion is in-process heat control, when both the equipments needed to prevent distortion and the applicability to general purpose is considered. Therefore, in-process control of welding distortion by using a heating or cooling source in addition to the welding torch is considered to be very practical for actual use.

An in-process method for controlling weld distortion in fillet welds has been developed, in light of the above-described back-ground. Angular distortion is particularly reduced by conducting triangular heating at a fixed distance of MAG welding. The effectiveness of this method is verified by experiment and by Geographic information system analysis in a fillet welded joint made of type AH36 steel. The appropriate heating conditions are determined through studying the mechanism by which welding distortion is reduced, and the effectiveness of the proposed in-process method during welding is finally validated.

## Experiment

The effectiveness of the method for in-process control of welding distortion is investigated by an actual experiment using a fillet-welded joint made of AH36 steel. Several parameters related to welding and heating conditions are varied in order to study their effect on welding distortion. The main type of welding distortion is considered to be angular distortion transverse bending. Longitudinal shrinkage is also considered when the appropriate conditions are discussed. This is because that angular distortion is much larger than other distortion modes such as longitudinal bending, transverse shrinkage, and rotational distortion. Longitudinal shrinkage may eventually cause buckling deformation and it often becomes important for practical use.

**Principle of Distortion Control:** The configuration of the tested fillet-welded plate joint, which is made of type AH36 steel, is shown in Fig. 1. The plate thickness of the flange was varied from 3 mm to 6 mm, and a 3-mm-thick web was fillet welded to the flange by fillet welding. The two sides were fillet welded sequentially at a constant speed of 30 mm/s by MAG or CO<sub>2</sub> welding with type 5183 filler metal 1.2 mm. The flange plate sat on a table with a slit to allow access of the MAG heating torch from top to bottom of the flange plate in triangular shape. The vertical web has been supported with 20-mm-tack weld in each of the four edges. The chemical composition and mechanical properties of the material are listed in Table 1. The triangular MAG heating was performed ahead of the triangular cooling mainly to prevent angular and linear distortion of the flange.

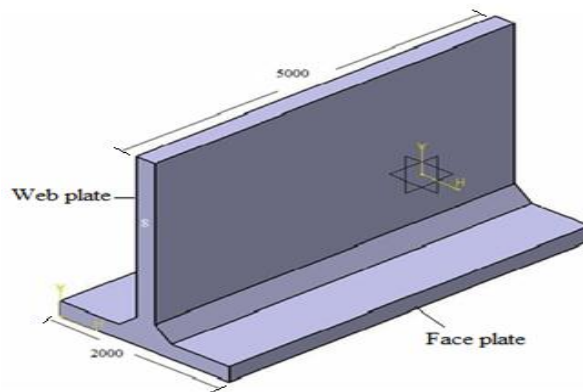

Fig. 1 Configuration of a fillet-welded joint

The in-process welding distortion control by the triangular heating is schematically illustrated in Fig. 2. The triangular cooling was conducted at a fixed distance, ahead of the MAG welding. It is considered that the distance  $D$  between the heating and cooling torches and the heat input of MAG heating,  $Q_{MAG}$ , are parameters that play an important role in controlling welding angular distortion and linear distortion. Weld sequence (methodology to perform welding sequence)

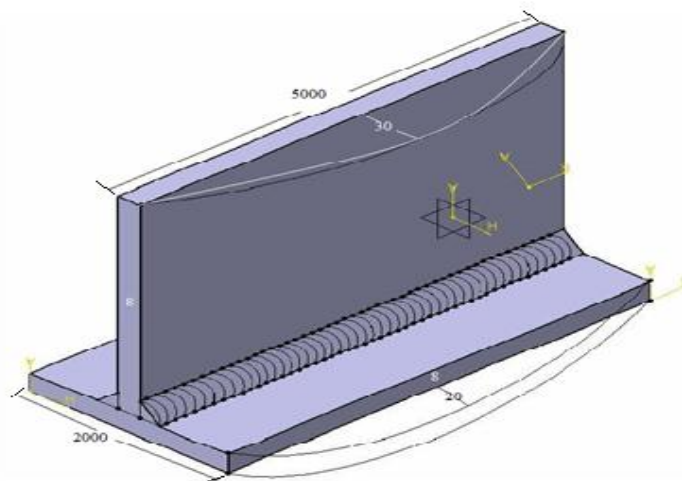

Fig. 2 Schematic illustration of welding distortion control by fairing

## II. Results of Experiment:

The relationship between web plate and face plate and their residual angular distortion is shown in Fig. 2. Positive angular distortion means that the flange has a concave upper surface. Residual angular distortion was small when the distance of preceding cooling torch was from about 50 mm to 300 mm. These angular distortions were smaller than that when MAG welding was performed before the cooling to increase the temperature caused preheating and the angular distortion caused by only MAG welding was nearly the same as that when cooling was conducted just after MAG welding. These results suggest that the reduction in distortion caused by the triangular heating is due not only to the opposite angular distortion caused by CO<sub>2</sub> heating but also to some factor such as a preheating effect.

The effect of MAG heat input  $Q_{MAG}$  on angular distortion can be obtained. It is clear that heat input from triangular heating parameter with thickness,  $Q_{MAG}$ , about 3000– 4000 J/cm<sup>3</sup> can effectively reduce angular distortion. This result means that the effect of the opposite angular distortion by MAG heating may saturate at a certain CO<sub>2</sub> heat input, even though the preheating effect becomes larger with increasing CO<sub>2</sub> heat input  $Q_{MAG}$ . It is concluded that the triangular heating method can reduce angular and linear distortion in welded joints. It is important to choose a suitable distance D between MAG and cooling torches and an adequate heat input  $Q_{MAG}$  for MAG heating. Total heat input including both sides MAG heating plays an important role in the quality of a welded joint such as toughness and strength. However, it is considered that the joint was sufficiently welded because the welding and heating speed were very high. Therefore, the total heat input did not become higher, so the quality of the welded joint might decrease.

The three control factors are:

- 1) Weld sequence (methodology to perform welding sequence)
- 2) Stitch length (welding is performed as stitched and later joined these stitches to complete the full welding)
- 3) Weld speed (welding voltage and current are two factors influences the speed for required leg length of the weld)

Distortion Control	Stitch Length (mm)	Weld Speed (mm/min)	Linear Distortion (mm)	Angular Distortion (mm)
Linear	250	320	3	4
Angular	150	400	4	2
Linear & Angular	200	400	3	2

### Mechanism of Reduction in Welding Distortion

The effectiveness of the in-process welding-distortion control method was confirmed by experiment in the previous section. Understanding the mechanism of reducing welding distortion is important in order to expand this method to many components. Various heating conditions, by changing the distance between the two torches, CO<sub>2</sub> heat input, and width of heating area, were examined by using LAB test analysis (GIS).

**Table 2.** Chemical Composition and Mechanical properties of AH36

Grade	C	Si	Mn	P	S	Cr	Mo	Ni	Cu	Cb	V
AH36	0.18	0.3	1.3	0.035	0.035	0.2	0.08	0.4	0.35	0.35	0.45

**Table 3.** Mechanical properties of AH36

Grade	Yield Strength	Tensile Strength	Elongation(mm)	
	Mpa	Mpa	A(50)	A(200)
AH36	355	490-620	22%	19%

**Analytical Model:** The analytical model for studying the mechanism by which welding distortion is produced during triangular heating. The minimum mesh size is 1 mm thickness, 2 mm width, and 10 mm length. The web is omitted from the model for simplification. This is because the main purpose of the tendency and the production mechanism of welding distortion. MAG welding from the one surface of the plate and triangular cooling from other surface are simultaneously performed by heat conduction while distance D is kept constant. The welding speed of both the MAG welding is 30 mm/s and numerically simulated by moving the heat source in the elements. The condition assumed in the analysis was a bead-on-plate configuration without filler metal.

The MAG welding width was set to 4 mm and the cooling torch width to 10 mm, based on the results of the experiment.

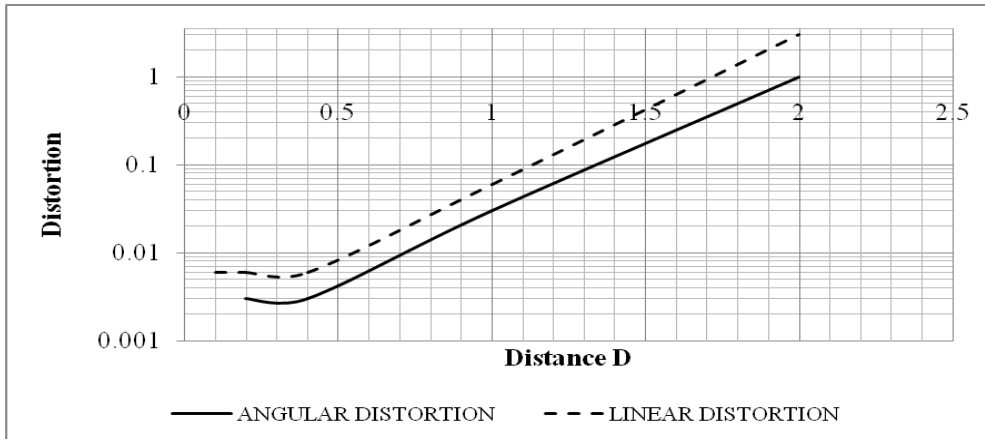

Fig 3 Angular and Linear distortion varies with respect to distortion

Physical and mechanical properties used in the heat-conduction and stress analyses are shown in Fig 3. These properties were determined by considering the characteristics of temperature dependence. Melting phenomena are treated by lowering Young’s modulus and yield stress at the high-temperature region. Heat transfer from the plate surface was considered by heat flux in the temperature analysis for MAG welding. Heat efficiency for the MAG welding and the preheating was determined by comparing the measured temperature distributions and histories with the computed values.

**Analytical Results:**

The angular distortion changes during welding at any position because temperature distribution transiently changes. Figure below shows the history of longitudinal distribution of angular distortion by MAG welding only. Angular distortion is generated immediately when the MAG torch reaches the evaluation line and saturates soon after the MAG torch passes. Residual angular distortion becomes larger at the end of the welding line than at the start, but the tendency of the history of generating distortion is the same at any position. Therefore, the angular distortion at the center transverse line is used in the following discussion. The history of angular distortion at the cross section of the plate center is shown in Fig. It is clear that large angular distortion is produced by MAG welding only, and an opposite large distortion is generated by triangular preheating only. By performing triangular cooling at a constant after MAG welding, residual angular distortion can be reduced.

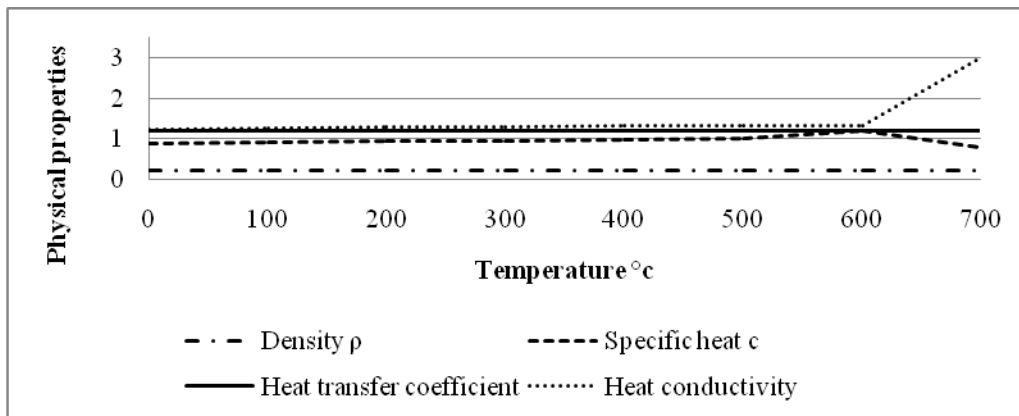

Fig 4 Physical properties for AH36 steel

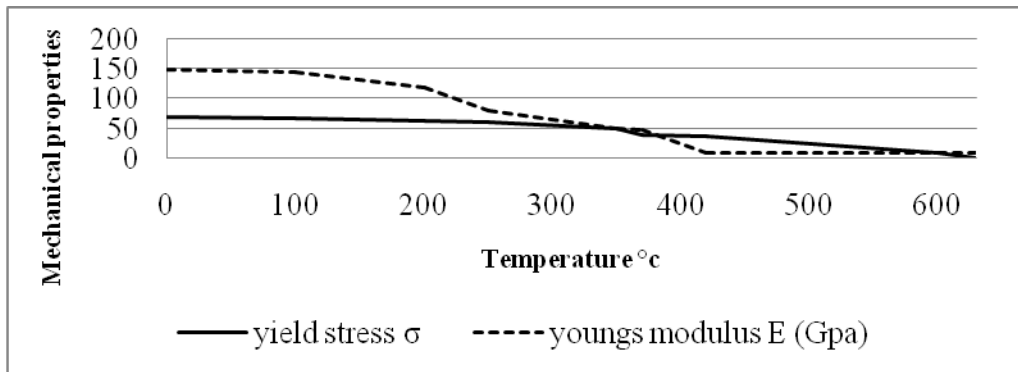

Fig 5 mechanical properties for AH36 steel

In this case, opposite distortion is produced by the triangular cooling until the MAG torch arrives at the center of the plate, then the distortion is finally reduced to almost zero by the MAG welding. The preheating effect is considered to also play an important role in welding distortion; therefore, the distortion history by only the MAG welding after preheating at 90°C was calculated. This is because the plate just after MAG welding was heated by preheating and temperature distribution near the weldment was almost constant. This distortion behavior and the behavior by the triangular cooling only can be elastically superposed. The history of the sum is nearly equal to the welding distortion behavior caused by the triangular heating method. This result suggests that the mechanism of distortion reduction during triangular heating includes both the effect of preheating by the MAG heating and the effect of the opposite-side angular distortion by the cooling.

It is considered that the mechanism for reducing angular distortion results from two main effects, preheating effect, and cooling effect on the triangular shape, which provides the opposite angular distortion by thermal strain. Only MAG welding was conducted after preheating. Angular distortion decreases with increasing preheating temperature. The temperature field near the weldment just before the MAG welding becomes higher, as the preceding distance  $D$  of triangular cooling after MAG welding decreases, this means that the preheating effect increases as distance  $D$  decreases. On the other hand, the history of angular distortion at the center of the plate caused by preheating. The horizontal axis, time  $t$ , represents the elapsed time until the start of MAG welding, and the equivalent distance  $D$  between the cooling torch and MAG torch can be calculated from the welding speed. This figure shows that the effect of the opposite-side angular distortion is low when distance  $D$  is small. It is necessary to choose appropriate conditions by considering both the preheating effect and the opposite-side distortion effect, although they have effects on the  $CO_2$  heat input.

The residual stress caused by MAG welding only is compared with that by triangular heating, Longitudinal Stress,  $\sigma_x$ , is dominant in the model because the plate is only 4 mm thick and transverse stress,  $\sigma_y$ , is hardly generated. Longitudinal stress distribution by MAG welding only is nearly the same as the other two distributions by MAG heating ahead of cooling. This is because the magnitude and distribution of residual stress are mainly determined by total heat input, and added  $CO_2$  heat input affects the width of the tensile stress area a little more than MAG welding only, but it does not affect the magnitude of residual stress.

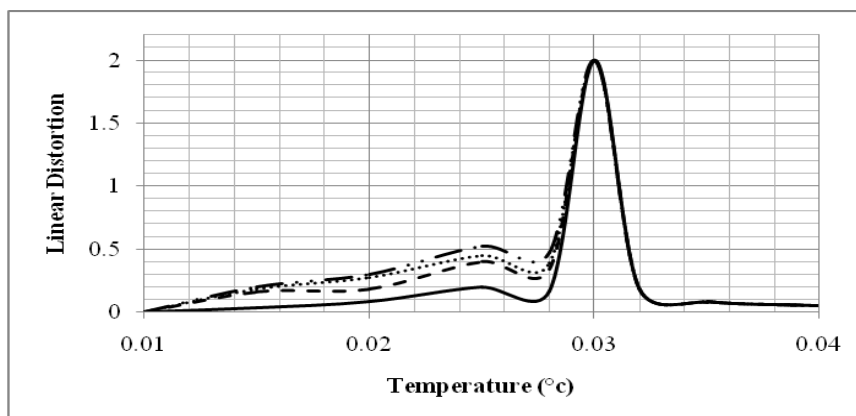

Fig 6 Linear distortion varies with respect to the temperature.

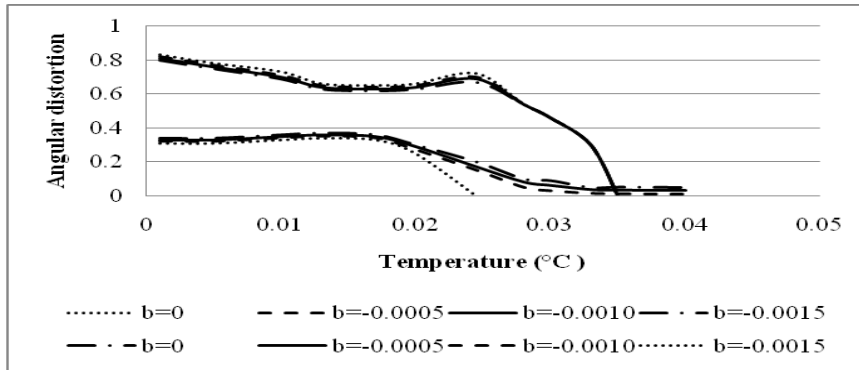

Fig 7 Angular distortion varies with respect to the temperature.

**Appropriate Conditions for Triangular Heating:** The effect of distance  $D$  between the cooling and MAG torches on angular distortion is shown in Fig.6. When heat input is 450 J/cm, residual angular distortion becomes small when the preceding distance  $D$  and this tendency matches the experimental results shown in Fig. 7. The angular distortion caused by MAG welding performed after reducing the temperature rise caused by triangular cooling is larger than that caused by fairing. The triangular heating method is more effective than the conventional method of pre-bending to produce opposite distortion prior to welding. This is because it not only produces an opposite distortion affected but also produces a pre-heating effect. On the other hand, the effectiveness of the preceding preheating is not so large when heat input is 225 J/cm. It is important that the appropriate heat input should be chosen by referring to the MAG heat input.

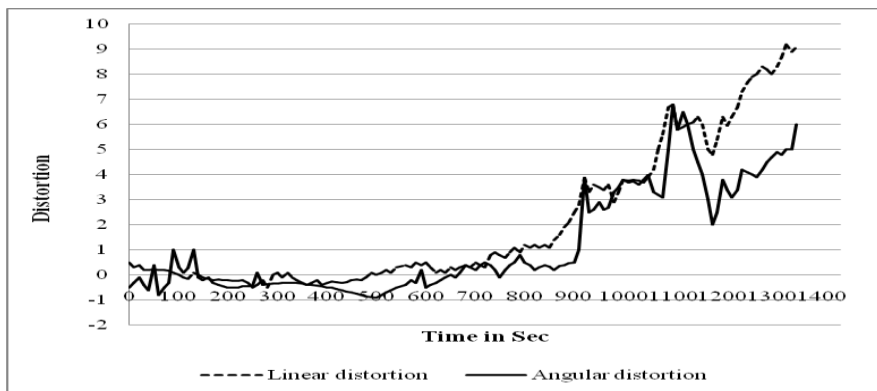

Fig 8 Linear and Angular distortion with respect to time

The effect of triangular cooling on angular distortion is shown in Fig 8. The relationships between longitudinal shrinkage and cooling effect are also shown. Residual angular distortion becomes smaller when an appropriate heat input is used, and the tendency of the results agrees with the measured values. Residual longitudinal shrinkage increases in proportion to heat input. Therefore, it is suitable for controlling both angular distortion and longitudinal shrinkage to choose a condition of lower heat input in the range of preheating that allows angular distortion to be reduced.

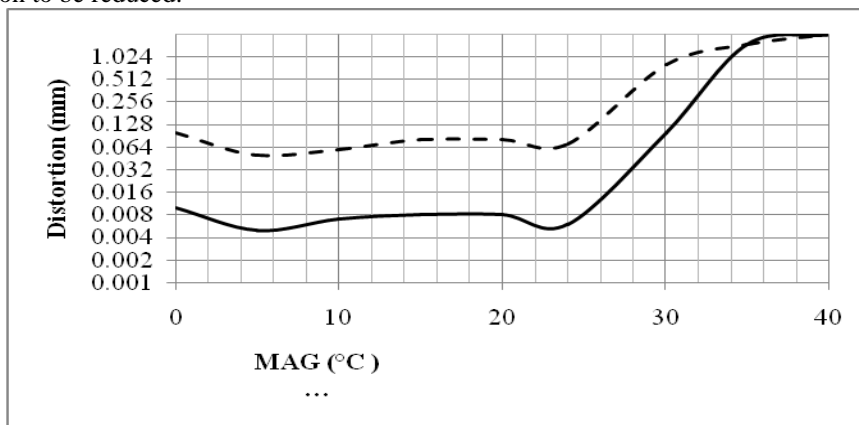

Fig 9 Angular distortion with respect to MAG welding.

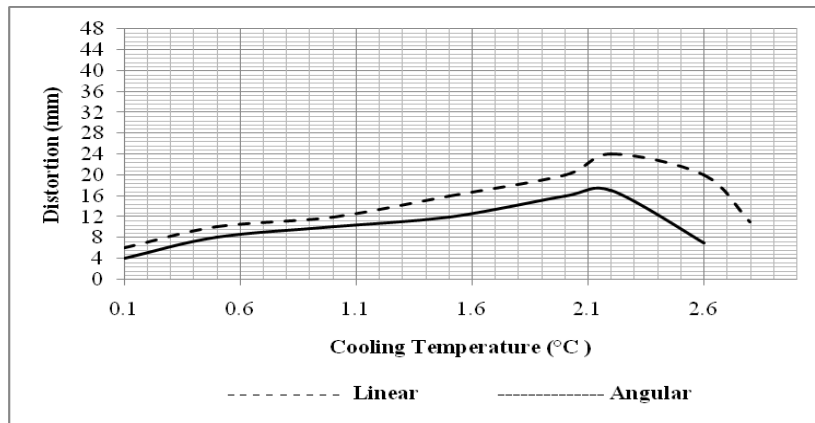

Fig 8 Linear distortion with respect to cooling temperature

Other heating sources for distortion control should also be investigated for expanding applicability in practical use. Gas heating or induction heating generally has a larger preheating area than MAG heating even for the same heat input. The effects of the preheating area two types of preheating area having the same heat input on angular distortion and longitudinal shrinkage in the triangular heating method. It is clear that the heat source with high energy density type W can effectively reduce the residual angular distortion with a lower heat input. This result shows that a heat source with high-energy-density triangular heating is effective for preventing angular distortion.

These results show that the active in-process triangular heating method effectively reduces angular distortion in fillet welds during the welding process when an appropriate condition is chosen. This controlling method has a possibility of the application to the practical fabrication of welded structures with complicated shapes.

### Summary

The developed in-process control method using triangular heating at a fixed distance ahead of cooling effect can reduce welding angular distortion in fillet welds. The effectiveness of this method was verified by experiment and by three-dimensional Geographic information system analysis of a fillet-welded joint. Various heating conditions were chosen in order to study the mechanism by which welding distortion is reduced. The reduction of angular distortion is a result of two main effects: one is that preheating on the triangular side provides the opposite angular distortion by thermal strain, and the other is the cooling effect. This method is thus effective for reducing angular and linear distortion.

### Acknowledgment

The authors would like to gratefully acknowledge M/s Hindustan Shipyard Limited, Visakhapatnam, for their kind help and cooperation in this study. This work was carried under the Department of ship building centre of Fabrication department, Hindustan Shipyard Limited, Visakhapatnam, AP, India.

### References

- [1]. E.Friedman, "Thermo mechanical Analysis of the Welding Process Using the GIS," J. Pressure Vessel Technol., 97, pp. 206–212, 1975.
- [2]. Rybicki, E. F., and Stonesifer, R. B., "Computation of Residual Stress due to Multipass Welds in Piping Systems," J. Pressure Vessel Technol., 101, pp. 149–154, 1979.
- [3]. Argyris, J. H., and Doltsinis, J.St., "On the Natural Formulation and Analysis of Large Deformation Coupled Thermo mechanical Problems," Compute Methods Appl. Mech. Eng., 25, pp. 195–253, 1980.
- [4]. Leblond, J. B., Mottet, G., and Devaux, J. C., "A Theoretical and Numerical Approach to the Plastic Behavior of Steels during Phase Transformation," J. Mech. Phys. Solids, 34, pp. 395–432, 1986.
- [5]. Goldak, J. A., "Modelling Thermal Stresses and Distortion in Welds," Proceedings Conference on Recent Trends in Welding Science and Technology, ASM, Gatlinburg, Tennessee, 196, pp. 71–82, 1989.
- [6]. Tekrewal, P., and Mazumder, J., "Transient and Residual Thermal Strain-Stress Analysis of GMAW," J. Eng. Mater. Technol., 113, pp. 336–343, 1991.
- [7]. Mochizuki, M., Enomoto, K., Okamoto, N., Saito, H., and Hayashi, E., "Welding Residual Stresses at the Intersection of a Small Diameter Pipe Pen-etrating a Thick Plate," Nucl. Eng. Des., 144, pp. 439–447, 1993.
- [8]. Janosch, J. J., and Clergè, M., 1997, "Numerical Welding Simulation of Two Pipes—Determination of the Evolution of Residual Stresses During Proof Test Pressure," Approximate Methods in the Design and Analysis of Pressure Ves-sels and Piping Components, 347, pp. 103–113, 1997.
- [9]. Dong, P., Zhang, J., and Li, M. V., "Computational Modeling of Weld Residual Stresses and Distortions—an Integrated Framework and Industrial Applications," Fatigue, Fracture, and Residual Stresses, 373, pp. 311–335, 1995.
- [10]. Karlsson, C. T., and Josefson, B. L., "Three-Dimensional GIS Analysis of Temperatures and Stresses in a Single-Pass Butt-Welded Pipe," J. Pressure Vessel Technol., 112, pp. 76–84, 1990.

- [11]. Brown, S., and Song, H., "Element Simulation of Welding of Large Structures," *J. Eng. Ind.*, 114, pp. 441–451, 1992.
- [12]. Michaleris, P., Feng, Z., and Campbell, G., "Evaluation of 2D and 3D GIS Models for Predicting Residual Stress and Distortion," *Approximate Methods in the Design and Analysis of Pressure Vessels and Piping Components*, PVP–Vol. 347, pp. 91–102, 1997.
- [13]. Toyoda, M., and Mochizuki, M., "Control of Mechanical Properties in Structural Steel Welds by Coupling Simulation of Temperature, Microstructure, and Macro-Mechanics," *Sci. Technol. Adv. Mater.*, 5, pp. 255–266, 2004.
- [14]. Mochizuki, M., Hayashi, M., Nakagawa, M., Tada, N., and Shimizu, S., "A Simplified Analysis of Residual Stress at Welded Joints Between Plate and Penetrating Pipe," *JSME JSMEInt. J., Ser. A*, 40, pp. 8–14, 1997.
- [15]. Mansour and Thayamballi, "The Localized Eigenstrain Method for Determination of Triaxial Residual Stress in Welds," *Fatigue, Fracture, and Residual Stresses*, PVP–Vol. 373, pp. 397–403, 1998.
- [16]. Gordo, "Comparison of Five Evaluation Methods of Residual Stress in a Welded Pipe Joint," *JSME Int. J., Ser. A*, 42, pp. 104–110, 1996.
- [17]. Rahman and Chowdhari and Nakakado, K., "Residual Stress Reduction and Fatigue Strength Improvement by Controlling Welding Pass Sequences," *ASME J. Eng. Mater. Technol.*, 122, pp. 108–112, 2006.
- [18]. Paik and Hattori, T. "Residual Stress Distribution Depending on Welding Sequence in Multi-Pass Welded Joints with X-Shaped Groove," *ASME J. Pressure Vessel Technol.*, 122, pp. 27–32, 2004.
- [19]. Byklum and Amdahl, Hayashi, M., Shiratori, M., and Yu, Q., "Analysis of Stress Intensity Factor due to Surface Crack Propagation in Residual Stress Fields Caused by Welding Comparison of Influence Function Method and Inherent Strain Analysis," *JSME Int. J., Ser. A*, 45, pp. 199–207, 2002.
- [20]. T S A Belenkiy and Raskin, C. L., Park, S. C., and Cheng, W. T., "Welding Distortion of a Thin-Plate Panel Structure – The Effect of Welding Sequence on Panel Distortion is Evaluated," *Weld. J. Miami, FL, U.S., Welding Research Supplement*, 78-5, pp. 156–165, 1999.
- [21]. Ziha, Hiroi, T., and Amano, Y., "Reduction of Residual Stress of Welded Joint Using Vibration," *Trans. Jpn. Soc. Mech. Eng., Ser. C*, 61C, pp. 4800–4804 in Japanese, 1995.
- [22]. Steen, Kazimirov, A. A., and Morgun, V. P., "Choosing an Optimal Temperature Field for Preliminary Heating of Plates in Welding," *Avtom. Svarka.*, 5, pp. 15–19, 1990.
- [23]. Cui, Guo, D. L., and Reggatt, R. H., "Low Stress Non-Distortion LSND Welding—A New Technique for Thin Materials," *Weld. World*, 33, pp. 160–167, 1994.
- [24]. Guan, Q., Zhang, C. X., and Guo, D. L., "Dynamic Control of Welding Distortion by Moving Spot Heat Sink," *Weld. World*, 33, pp. 308–312, 1994.
- [25]. Song, J., Shangvi, J. Y., and Michaleris P., "Sensitivity Analysis and Optimization of Thermo-Elasto-Plastic Processes with Applications to Welding Side Heater Design," *Comput. Methods Appl. Mech. Eng.*, 193, pp. 4541–4566, 2004.
- [26]. Toyoda, M., Mochizuki M., and Mikami Y., "Metallurgical and Mechanical Heterogeneity in Weld Materials Considering Multiple Heat Cycles and Phase Transformation," *Mater. Sci. Forum*, 512, pp. 19–24, 2006.
- [27]. Mochizuki, M., and Toyoda, M., "Strategy of Considering Microstructure Effect on Weld Residual Stress Analysis," *ASME J. Pressure Vessel Technol.*, 129, pp. 67, 2007.
- [28]. Mochizuki, M., "Control of Welding Residual Stress for Ensuring Integrity Against Fatigue and Stress-Corrosion Cracking," *Nucl. Eng. Des.* 237, pp 676, 2007.