

NO_x Reduction of Diesel Engine with Madhuca Indica biodiesel using Selective Catalytic Reduction (SCR) in different flow rates

Dr. C. Solaimuthu¹, Dr. S. Chitra², Prof. P. Rajasekaran³, B. Abhijit,
G. Jayaprakash, V. Arunkumar and R. Lokesh

¹Professor cum Director (Research), Department of Mechanical Engineering, Er. Perumal Manimekalai College of Engineering, Hosur – 635 117, Tamil Nadu, India (Corresponding Author)

² Principal, Er. Perumal Manimekalai College of Engineering, Hosur – 635 117, Tamil Nadu, India

³Assistant Professor and Head, Department of Mechanical Engineering, Er. Perumal Manimekalai College of Engineering, Hosur – 635 117, Tamil Nadu, India

U.G Scholars, Department of Mechanical Engineering, Er. Perumal Manimekalai College of Engineering, Hosur – 635 117, Tamil Nadu, India

Abstract: A comparison analysis for different flow rates of urea-water selective catalytic reduction (SCR) has been carried out on a direct injection diesel engine. An optimum nozzle opening pressure of 250 bar and static injection timing of 20°bTDC is considered because these conditions only were found to give minimum emissions and better performance. An engine set up with SCR is made to study the influence of SCR on reduction of emissions from the diesel engine. The volume flow rate of 1, 2, 3, 4 and 5 ml/minute have been used with a mixture of 30% urea and 70% water as SCR for the entire experiment. From the test results, it could be noted that, among all flow rates, the volume flow rate of 3 ml/minute gives better performance, combustion and lowest emissions. Among the blends, B100 gives lowest emissions of smoke density and hydrocarbon as compared to without SCR. But in the presence of SCR, there is a drastic reduction in NO_x of 17.81% for B100 as compared to without SCR at full load condition of the engine.

Keywords: Diesel Engine, Performance, Emissions, Mahua Oil Methyl Ester (MOME), Selective Catalytic Reduction (SCR)

I. Introduction

The diesel engine sector forms a vital part of transportation systems in all the developed and developing countries of the world. However, diesel engine exhaust emissions are a major contributor to environment pollution. The conventional fossil fuel (diesel) used in diesel engines contains higher amounts of aromatics and sulphur, which cause environment pollution. As an example, higher amount of particulate matter (PM), unburned hydrocarbon (HC), oxides of nitrogen (NO_x), carbon dioxide (CO₂) and oxides of sulphur (SO_x) are produced from fossil-fuelled diesel engine exhaust emissions. Moreover, NO_x and CO₂ are the green house gases and SO_x causes acid rain. Bio-fuel contains less aromatic content and is practically sulphur-free, and produces complete combustion due to its oxygen content in comparison with conventional diesel fuel. Secondly, the environmental benefit is another motivation factor due to a lesser green house effect, less local air pollution, less contamination for water and soil and a reduced health risk. Why SCR is preferable? There are some techniques to rectify the domination of NO_x which comes from exhaust of diesel engine. Exhaust gas recirculation (EGR) and selective catalytic reduction (SCR) are two methods to rectify the NO_x. EGR is one of the methods to reduce the NO_x. However, the use of EGR leads to rise in soot emission because of soot-NO_x trade-off. But SCR gives better reduction in NO_x without any problem of soot emissions. This study is focussed on Mahua Oil Methyl Ester. Mahua Oil Methyl Ester and its blend in different volumetric proportions with fossil diesel are used to study the performance, combustion and emission characteristics with and without SCR at full load condition. A brief review of literature survey in this field is presented below. Narayana Reddy and Ramesh [1] investigated performance and emissions of diesel with jatropa biodiesel fuel. They concluded that jatropa oil biodiesel gives similar performance and emissions as diesel when its injection timing is optimum. Venkatramanand Devaradjane [2] investigated performance and emission characteristics of diesel engine with Pungam Oil Methyl Ester (POME) diesel blends. They concluded that PME 20 could be used as alternative fuel for diesel engine with compression ratio of 19:1. Vijayashree et al., [3] highlighted overview of global energy scenario. They concluded that experience from all over the world has shown that improving end use efficiency will be hands down winner in economic terms when compared to capacity addition. Asad et al., [4] performed the diesel engine emission characteristics keeping in mind that reduction of emissions of CO, HC, NO_x especially carbonyl species like formaldehyde, acetaldehyde, acrolein, acetone and propional dehyde are greatly reduced in the presence of the SCR system. Clark et al., [5] performed the diesel engine with soybean biodiesel. They concluded that soy bean biodiesel gives higher specific fuel consumption and lower emissions except

NO_x. Dan Haupt and Kent Nord [6] evaluated the diesel engine emissions with diesel fuel. They concluded that the reduction of emissions of CO, HC, NO_x especially carbonyl species like formaldehyde, acetaldehyde, acrolein, acetone and propionaldehyde are greatly reduced in the presence of the EGR system. Kapilan and Reddy [7] performed the diesel engine with biodiesel. They concluded that, the impact of pure biodiesel is lower than that of pure diesel. Manfred Koebel et al., [8] performed the diesel engine with diesel fuel. They concluded that, there was a reduction in NO_x obtained with urea as a reducing agent and a standard SCR catalyst based on TiO₂-WO₃-V₂O₅. Puhan et al., [9] performed engine tests with mahua biodiesel in naturally aspirated diesel engines. They used neat diesel and neat biodiesel. Emissions are measured and reported that the impact of biodiesel (B100) is lower than that of diesel (B0). Puhan et al., [10] reported the biodiesel preparation and discussed its performance and emission characteristics of diesel engine with B0 and B100 fuel. They made the conclusion that the Mahua Oil Methyl Ester (B100) burn more efficiently than diesel (B0) and the emissions of B100 is lower than that of B0. Raheman and Ghadge [11] considered mahua biodiesel blended with fossil diesel and discussed extensively the engine performance obtained by blend with different volumetric ratios. They concluded that biodiesel 20% by volume with 80% diesel formed an optimum mixture for their engine parameters. Martin and Prithviraj [12] operated the diesel engine with various blends of preheated cotton seed oil. They concluded that there was increase in brake thermal efficiency and reduction in exhaust gas temperature, smoke, carbon monoxide and hydrocarbon as that of fossil diesel fuel. Mahla Das and Babu [13] performed the diesel engine with natural gas using EGR technique. They concluded that there was significant increase in brake thermal efficiency while using up to 5% cooled EGR and reduction in smoke, oxides of nitrogen and carbon monoxide as that of neat diesel fuel. Krishna Reddy et al., [14] operated diesel engine fuelled with Cotton Seed Oil Methyl Ester (CSOME) blends B10, B20, B30 and B40. The B10 and B20 have given almost same performance of diesel engine while compared to petro-diesel (B0) at full load. Sivakami et al., [15] investigated the DI diesel engine fuelled with Cotton Seed Oil Methyl Ester. 30% water emulsion with biodiesel results in a substantial reduction of NO_x by 30% and smoke emissions by 32% with a marginal decrease in brake thermal efficiency compared to petro-diesel at full load conditions without emulsion.

From the previous studies, it could be observed that most of the studies were mainly related to the performance, combustion and emission characteristics of diesel engine using neat biodiesel as fuel in various blends without SCR technique. In other part, the SCR techniques have been adopted in diesel engine with diesel fuel only. Therefore not much work has been carried out on the SCR with biodiesel and its different blends of fuel. In this paper a detailed analysis of performance and emissions of diesel engine with optimum nozzle opening pressure of 250 bar and static injection timing of 20° bTDC at full load with SCR in various volume flow rate of 1, 2, 3, 4 and 5 ml/minute have been used using B0, B25, B50, B75 and B100 as fuel and the optimum flow rate has been identified and the same is compared to without SCR technique is presented. The comparison chart between with and without SCR is also discussed and presented.

II. Experimental Setup And Procedure

Table 1 Specification details of the engine and SCR setup

Make	Kirloskar TV – I
Type	single cylinder Vertical DI diesel engine
Compression ratio	17.5:1
Bore × Stroke	87.5 mm x 110 mm
Rated brake power	5.2 kW
Speed	1500 rpm
Cooling system	Water cooled
Nozzle opening pressure	250 bar (modified)
Static injection timing	20° bTDC (modified) at full load
Make	SCR setup
Name of the substance	Aqueous urea solution
Chemical formula	(NH ₂) ₂ CO.H ₂ O
Molecular weight	66.06 g/mol
Density at 15°C	1085 kg/m ³
Composition	30% of urea and 70% of water
Volume flow rates	1, 2, 3, 4 and 5 ml/minute

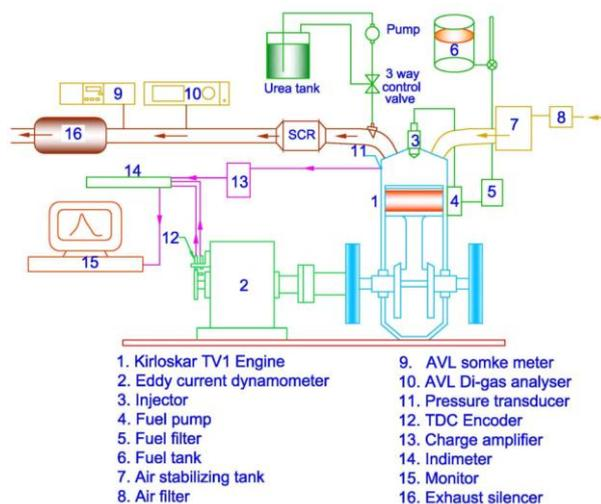

Figure 1. Schematic diagram of the engine test setup

Table 2 Properties of Mahua biodiesel and its diesel blends

S. No	Name of the Properties	ASTM Code	B0	B25	B50	B75	B100
1	Gross Calorific Value in MJ/kg	D4809	45.6	43.9	43.3	42.5	41.9
2	Kinematic Viscosity at 40°C in cSt	D2217	2.6	3.49	4.17	4.98	6.04
3	Flash Point in °C	-	65	71	78	112	170
4	Fire Point in °C	-	70	79	88	123	183
5	Cloud Point in °C	-	-15	4	8	11	13
6	Specific Gravity	D445	0.82	0.83	0.85	0.87	0.88
7	Cetane Number	-	46	51.6	51.7	51.8	52.4

The schematic of the engine setup is shown in Figure 1. Specifications of the engine is presented in Table 1. The optimum nozzle opening pressure of 250 bar and static injection timing of 20°bTDC are used for the entire experiments at full load condition. Smoke level is measured using standard AVL 437 smoke meter. AVL 444 digital gas analyzer is used for the measurement of exhaust emission of HC, CO₂ and NO_x. All the readings were taken under steady state conditions.

III. Experimental Setup and Procedure of SCR

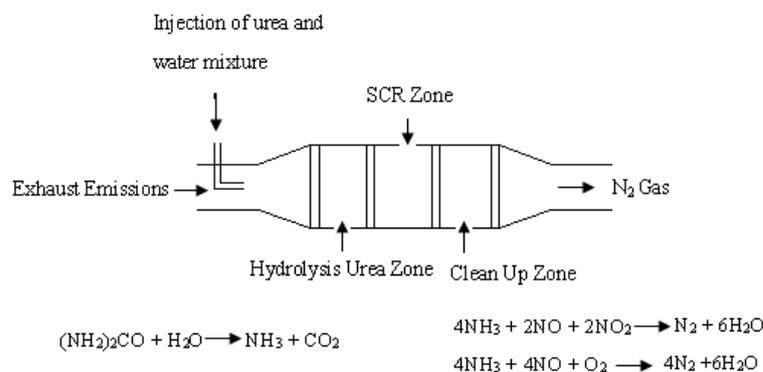
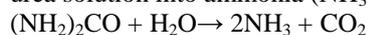

Figure 2. Schematic diagram of the SCR setup

The schematic of the SCR setup is shown in Figure 2. The selective catalytic converter (SCR) is used in diesel engine for mainly reducing the NO_x. The working principle is to evaporate and then decompose the urea solution into ammonia (NH₃). The following chemical equations show the conversion of N₂ with SCR [4].



Ammonia serves as the reducing agent in the catalyst, and the significant reactions are given as follows:



IV. Results And Discussion

4.1 SPECIFIC FUEL CONSUMPTION

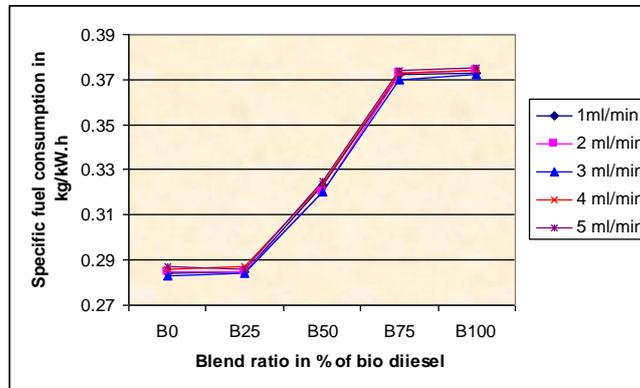

Figure 3. Specific fuel consumption vs Blend ratio

Figure 3 shows variation of specific fuel consumption with respect to blend ratio of the volume flow rate of 1, 2, 3, 4 and 5 ml/minute for B100 to B0 at full load condition. It could be seen that, there is an increasing trend observed with respect to blends of fuel. It could also be observed that, there is not much variation in specific fuel consumption in the case of various volume flow rate at maximum load condition. However, 3 ml/minute volume flow rate gives lowest value in specific fuel consumption compared to all other flow rates.

4.2 BRAKE THERMAL EFFICIENCY

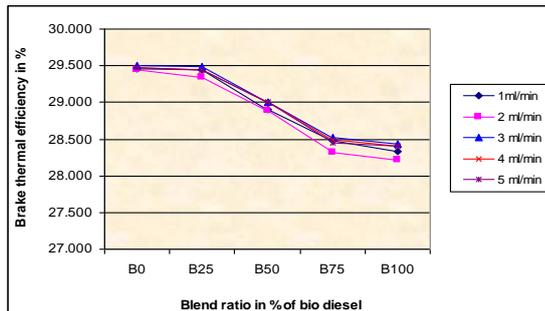

Figure 4. Brake Thermal Efficiency vs Blend Ratio

Figure 4 shows variation of brake thermal efficiency with respect to blend ratio of the volume flow rate of 1, 2, 3, 4 and 5 ml/minute for B100 to B0 at full load condition. It could be seen that, there is a decreasing trend observed with respect to blends of fuel. It could also be observed that, there is not significant variation in brake thermal efficiency in the case of various volume flow rate at maximum load condition. Among the flow rates, 3 ml/minute volume flow rate gives highest brake thermal efficiency.

4.3 HEAT RELEASE RATE

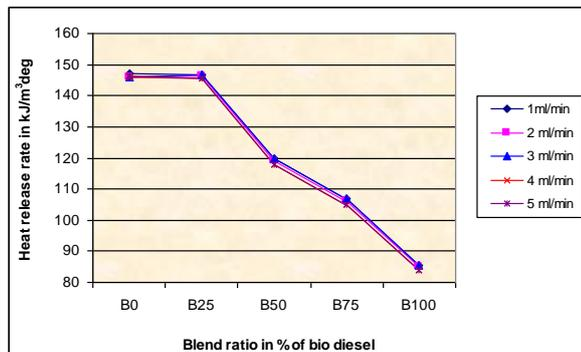

Figure 5. Heat Release Rate vs Blend Ratio

Figure 5 shows variation of heat release rate with respect to blend ratio of the volume flow rate of 1, 2, 3, 4 and 5 ml/minute for B100 to B0 at full load condition. It could be seen that, there is a decreasing trend observed with respect to blends of fuel. It could also be observed that, there is not much significant variation in heat release rate in the case of various volume flow rate at full load condition. Among the flow rates, 3 ml/minute volume flow rate gives highest value in heat release rate.

4.4 MAXIMUM CYLINDER PRESSURE

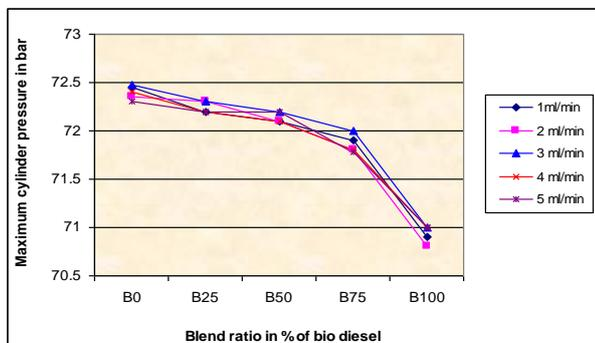

Figure 6. Maximum Cylinder Pressure vs Blend Ratio

Figure 6 shows variation of maximum cylinder pressure with respect to blend ratio of the volume flow rate of 1, 2, 3, 4 and 5 ml/minute for B100 to B0 at full load condition. It could be seen that, there is a decreasing trend observed with respect to blends of fuel. It could also be observed that, there is not significant variation in maximum cylinder pressure in the case of various volume flow rate at full load condition. Among the flow rates, 3 ml/minute volume flow rate gives highest value in heat release rate.

4.5 CARBON DIOXIDE

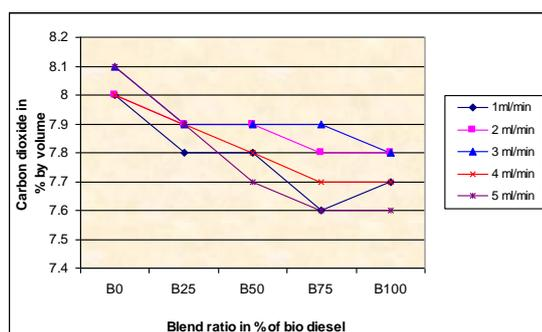

Figure 7. Carbon dioxide vs Blend Ratio

Figure 7 shows variation of carbon dioxide with respect to blend ratio of the volume flow rate of 1, 2, 3, 4 and 5 ml/minute for B100 to B0 at full load condition. From the test results, it could be stated that, among the flow rates, 3 ml/minute volume flow rate gives highest value in carbon dioxide. This may be due to the oxygen content and cetane number of the blend. Since the methyl ester of mahua oil based fuel contains oxygen in the fuel itself and it acts as a lesser combustion promoter inside the cylinder. From the table 2, it could be noted that the cetane number of B25, B50, B75 and B100 are higher than that of B0.

4.6 SMOKE DENSITY

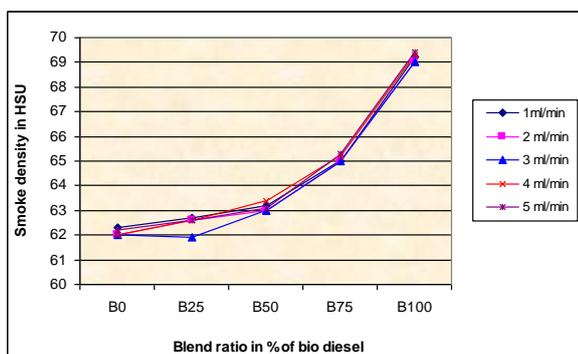

Figure 8 Smoke Density vs Blend Ratio

Figure 8 shows variation of smoke density with respect to blend ratio of the volume flow rate of 1, 2, 3, 4 and 5 ml/minute for B100 to B0 at full load condition. From the test results, it could be stated that, among the flow rates, 3 ml/minute volume flow rate gives lowest value in smoke density. It is interesting to note that B25 emits lower smoke compared to B0. This may be due to the chemistry of fuel blend which may promise conducive atmosphere for lower smoke density for B25 compared to B0. From table 2, it is evident that specific gravity difference for B25 compared to B0 is quite small (0.82 to 0.83) and the fire point increase is less than 10°C. Further there is good increase (46 to 51.6) in cetane number between B0 and B25. Probably this is the reason for decrease in smoke density at full load.

4.7 HYDROCARBON

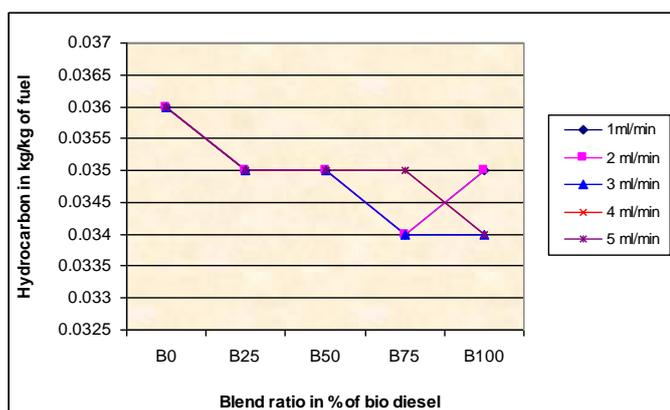

Figure 9 Hydrocarbon vs Blend Ratio

Figure 9 shows variation of hydrocarbon with respect to blend ratio of the volume flow rate of 1, 2, 3, 4 and 5 ml/minute for B100 to B0 at full load condition. From the test results, it could be stated that, among the flow rates, 3 ml/minute volume flow rate gives lowest value in smoke density. As could be seen that there is not much variation in hydrocarbon. Cetane number of the fuel plays a vital role in ignition process. From table 2, we have seen that the cetane number of B100 is higher than that of B0 (46 to 52.4). Therefore the B0 emits more hydrocarbon than that of B100 [9].

4.8 OXIDES OF NITROGEN

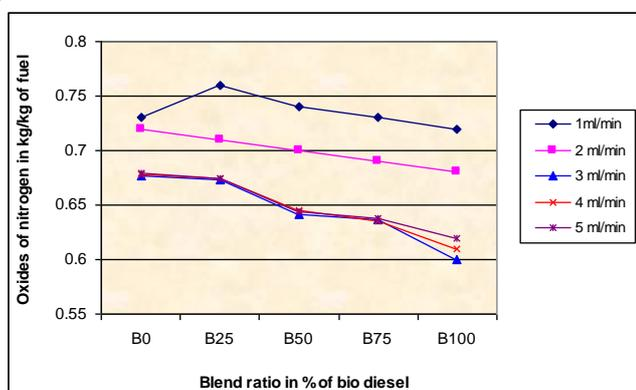

Figure10 Oxides of Nitrogen vs Blend Ratio

Figure 10 shows variation of oxides of nitrogen with respect to blend ratio of the volume flow rate of 1, 2, 3, 4 and 5 ml/minute for B100 to B0 at full load condition. From the test results, it could be stated that, among the flow rates, 3 ml/minute volume flow rate gives lowest value in oxides of nitrogen. It is very interesting to note that 3, 4 and 5 ml/minute give almost same NO_x value. Therefore among 3, 4 and 5 volume flow rates, 3 ml/minute has given optimum flow rate compared to other flow rates. The remaining flow rates like 4 and 5 ml/minute give ammonia slip. This will lead to toxic emissions. It is well known that more than optimum condition of urea flow rate should be avoided which creates ammonia slip. From these findings, it could be stated that, 3 ml/minute gives lowest emissions of NO_x without any ammonia slip and toxic emissions. The percentage reduction in NO_x in the case of 3 ml/minute volume flow rate for B0, B25, B50, B75 and B100 are 7.26%, 11.47%, 13.24%, 12.88% and 16.67% respectively as compared to 1 ml/minute flow rate at full load condition. The B100 gives highest percentage reduction in NO_x in the case of 3 ml/minute as compared to 1 ml/minute. This may be due to spraying urea water mixture gradually with uniform flow rate of 3 ml/minute during the passage of exhaust gas which comes from diesel engine during operation. From equations

2, 3 and 4, it could be stated that, the urea react with water gives ammonia. Then further gives N₂ gas only. This may be the reason to have lower in NO_x with SCR compared to without SCR [4].

V. Conclusions

From these findings, it could be concluded that the optimum volume flow rate of 3 ml/minute gives better performance, combustion and lower emissions when compared with all other flow rates at full load condition. The optimum flow rate affects only oxides of nitrogen rather than others including performance and combustion. Among the blends B100 gives lowest emissions of smoke density and hydrocarbon as compared to without SCR. But in the presence of SCR, there is a drastic reduction in NO_x of 17.81% for B100 as compared to without SCR at full load condition.

Acknowledgement

The authors have thanked the Management of Er. Perumal Manimekalai College of Engineering, Hosur, Tamil Nadu, India for providing the support and encouragement to take the readings at I.C Engines Laboratory, Department of Mechanical Engineering, Er. Perumal Manimekalai College of Engineering, Hosur – 635 117, Tamil Nadu, India.

References

- [1] J Narayana Reddy and A. Ramesh, *Experimental investigation on a compression ignition engine fuelled with bio diesel of jatropha oil* *International Journal of Green energy, energy and environment*, 1(3), 2010, 1-6.
- [2] M Venkatraman and G. Devaradjane, *Experimental investigation of performance and emission characteristics of diesel-pungam oil methyl esters (PME) diesel blends fuelled D.I diesel engine at optimum engine operating parameters* *International Journal of Green energy, energy and environment* 1, 2010, 7-12.
- [3] Vijayashree, P. Tamilporai and V. Ganesan, *Global energy scenario – an overview*, *International Journal of Green energy, energy and environment*, 1(1), 2010, 1-12.
- [4] Asad Naem Shah, Yun-Shan GE, Lei Jiang and Zhi-Hua Liu, *Performance evaluation of a urea-water selective catalytic reduction (SCR) for controlling the exhaust emissions from a diesel engine*, *Turkish Journal of Engineering and Environmental Sciences*, 33, 2009, 259-271.
- [5] S.J Clark, L. Wanger, M.D. Schrock and P.G. Piennaar, *Methyl and ethyl soybean ester as renewable fuels for diesel engines*, *Journal of American Oil Chemists Society*, 61, 1984, 1632-1637.
- [6] Dan Haup and Kent Nord, *Hydrocarbon and aldehydes from a diesel engine running on ethanol and equipped with EGR, catalyst and DPF*, *SAE International*, 2004-01-1882.
- [7] N. Kapilan, and R.P. Reddy, *Evaluation of methyl esters of mahua oil (madhuca indica) as diesel fuel*, *Journal of American Oil Chemists*, 85, 2008, 185-188.
- [8] Manfred Koebel, Martin Elsener and Thomas Marti, *Combustion Science and Technology*, 121, 1996, 85-102.
- [9] S. Puhan, N. Vedaraman, V. Boppana, B. Ram, G. Sankaranarayanan, and K. Jeychandran, *Mahua oil (Madhuca Indica seed oil) methyl ester as biodiesel preparation and emission characteristics*, *Biomass and Bioenergy*, 28, 2005, 87-93.
- [10] S. Puhan, N. Vedaraman, G. Sankaranarayanan, V. Boppana and B. Ram, *Performance and emission study of mahua oil (madhuca indica oil) ethyl ester in a 4 stroke natural aspirated direct injection diesel engine*, *Renewable Energy*, 30, 2005, 1269-1278.
- [11] H. Raheman and S.V. Ghadge, *Performance of compression ignition engine with Mahua (Madhuca Indica) biodiesel*, *Fuel*, 86, 2007, 2568-2573.
- [12] M. Martin and D. Prithviraj, *Performance of Pre-heated Cottonseed Oil and Diesel Fuel Blends in a Compression Ignition Engine*, *Jordan Journal of Mechanical and Industrial Engineering*, 5(3), 2011, 235-240.
- [13] S.K. Mahla, L.M. Das, and M.K.G. Babu, *Effect of EGR on Performance and Emission Characteristics of Natural Gas Fuelled Diesel Engine* *Jordan Journal of Mechanical and Industrial Engineering*, 4(4), 2010, 523-530.
- [14] A.V. Krishna Reddy, M. Shiva Shankar and K. Apparao, *Experimental determination of brake thermal efficiency and brake specific fuel consumption of diesel engine fuelled with biodiesel*, *International Journal of Engineering and Technology*, 2(5), 2010, 305-309.
- [15] K. Sivasami, V. Selladurai, S.R. Devadasan and K. Rajan, *Reduction of NO_x and Smoke Emission with the effect of Biodiesel-Water Emulsion Mixture Fuel in a Diesel Engine*, *International Journal of Engineering and Technology*, 5(5), 2013, 4378-4387.