

## Power Quality Improvement from Grid Connected Renewable Energy Sources At Distribution Level Using Fuzzy Logic Controller.

Y. Anil Kumar, G. Veeranjanyulu

<sup>1</sup>M.Tech Student Scholler (Power Systems), <sup>2</sup>Asst. Professor, EEE Department R.V.R & J.C College of Engg

---

**Abstract:** Harmonic pollution of the power supply system has risen significantly in recent years due primarily to an increase of non-linear loads connected to the utility through residential, commercial and industrial customers. Power supply voltages become distorted due to the high level of undesired harmonic current drawn from the utility. Additionally, drops in fundamental voltage are caused by the interaction between the reactive current and network impedances. Renewable energy resources (RES) are being increasingly connected in distribution systems utilizing power electronic converters. This paper presents a novel control strategy for achieving maximum benefits from these grid-interfacing inverters using the closed loop fuzzy logic control, when installed in 3-phase 4-wire distribution systems. The inverter is controlled to perform as a multi-function device by incorporating active power filter functionality. The inverter can thus be utilized as: power converter to inject power generated from RES to the grid, and 1) shunt APF to compensate current unbalance, load current harmonics, load reactive power demand and load neutral current. All of these functions may be accomplished either individually or simultaneously. This new control concept is demonstrated with extensive MATLAB/Simulink. Finally the proposed scheme is implemented using conventional DC link controller and intelligence controller.

**Index Terms:** Point of Common Coupling (PCC), power quality, Photo Voltaic (PV) System, Fuzzy Logic Controller (FLC).

---

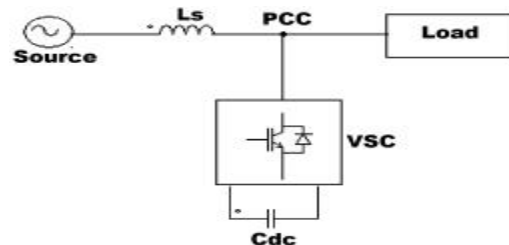
### I. Introduction

Power electronic converters, ever more widely used in industrial, commercial, and domestic applications, suffer from the problem of drawing non-sinusoidal current and reactive power from the source. This behavior causes voltage distortion that affects other loads connected at the same point of common coupling (PCC). Electric Power quality is a term which has captured increasing attention in power engineering in the recent years, the measure of power quality depends upon the needs of the equipment that is being supplied. What is good power quality for an electric motor may not be good enough for a personal computer. Usually the term power quality refers to maintaining a sinusoidal waveform of bus voltages at rated voltage and frequency. The waveform of electric power at generation stage is purely sinusoidal and free from any distortion. Many of the Power conversion and consumption equipment are also designed to function under pure sinusoidal voltage waveforms. However, there are many devices that distort the waveform. These distortions may propagate all over the electrical network. In recent years, there has been an increased use of non-linear loads which has resulted in an increased fraction of non-sinusoidal currents and voltages in Electric Network. Classification of power quality areas may be made according to the source of the problem such as converters, magnetic circuit non linearity, arc furnace or by the wave shape of the signal such as harmonics, flicker or by the frequency spectrum (radio frequency interference). The wave shape phenomena associated with power quality may be characterized into synchronous and non synchronous phenomena. Synchronous phenomena refer to those in synchronism with A.C waveform at power frequency. Recently Active Power Line Conditioners (APLC) or Active Power Filters (APF) overcome these problems and are designed for compensating the harmonics and suppressing the reactive power simultaneously. Since basic principles of active filter compensation were proposed by Gyugyi and Strycula in 1976. In 1984, Hirofumi Akagi introduced a new concept of instantaneous reactive power (p-q theory) compensators. The generalized instantaneous reactive power theory which is valid for sinusoidal or non-sinusoidal and balanced or unbalanced three-phase power systems with or without zero-sequence currents was later proposed. The active filter can be connected in series or in parallel with the supply network. The series active power filter is suitable for voltage harmonic compensation. Most of the industrial applications need current harmonic compensation, so the shunt active filter is popular than series active filter. Currently, remarkable progress in the capacity and switching speed of power semiconductor devices such as insulated-gate bipolar transistors (IGBTs) has spurred interest in APF. Actually, a passive LC power filter is used to eliminate current harmonics when it is connected in parallel with the load. This compensation equipment

has some drawbacks, due to which the passive filter cannot provide a complete solution. These disadvantages are mainly the following.

1. The compensation characteristics heavily depend on the system impedance because the filter impedance has to be smaller than the source impedance in order to eliminate source current harmonics. 2. Overloads can happen in the passive filter due to the circulation of harmonics coming from nonlinear loads connected near the connection point of the passive filter.

They are not suitable for variable loads, since, on one hand, they are designed for a specific reactive power, and on the other hand, the variation of the load impedance can detune the filter.



**Fig.1** shows the basic structure of proposed inverter

Renewable energy source (RES) integrated at distribution level is termed as distributed generation (DG). The utility is concerned due to the high penetration level of intermittent RES in distribution systems as it may pose a threat to network in terms of stability, voltage regulation and power-quality (PQ) issues. Therefore, the DG systems are required to comply with strict technical and regulatory frameworks to ensure safe, reliable and efficient operation of overall network. With the advancement in power electronics and digital control technology, the DG systems can now be actively controlled to enhance the system operation with improved PQ at PCC. However, the extensive use of power electronics based equipment and non-linear loads at PCC generates harmonic currents, which may deteriorate the quality of power. Grid-connected three-phase photovoltaic (PV) systems are nowadays recognized for their contribution to clean power generation. A primary goal of these systems is to increase the energy injected to the grid by keeping track of the maximum power point (MPP) of the panel, by reducing the switching frequency, and by providing high reliability. In addition, the cost of the power converter is also becoming a decisive factor, as the price of the PV panels is being decreased. This has given rise to a big diversity of innovative converter configurations for interfacing the PV modules with the grid. Generally, current controlled voltage source inverters are used to interface the intermittent RES in distributed system. Recently, a few control strategies for grid connected inverters incorporating PQ solution have been proposed. In an inverter operates as active inductor at a certain frequency to absorb the harmonic current. But the exact calculation of network inductance in real-time is difficult and may deteriorate the control performance. A similar approach in which a shunt active filter acts as active conductance to damp out the harmonics in distribution network is proposed in a control strategy for renewable interfacing inverter based on – theory is proposed. In this strategy both load and inverter current sensing is required to compensate the load current harmonics. The non-linear load current harmonics may result in voltage harmonics and can create a serious PQ problem in the power system network. Active power filters (APF) are extensively used to compensate the load current harmonics and load unbalance at distribution level. This results in an additional hardware cost.

Conventionally, PI, PD and PID controller are most popular controllers and widely used in most power electronic appliances however recently there are many researchers reported successfully adopted Fuzzy Logic Controller (FLC) to become one of intelligent controllers to their appliances [3]. With respect to their successful methodology implementation, this kind of methodology implemented in this paper is using fuzzy logic controller with feed back by introduction of voltage respectively. The introduction of change in voltage in the circuit will be fed to fuzzy controller to give appropriate measure on steady state signal.

The fuzzy logic controller serves as intelligent controller for this propose. However, in this paper authors have incorporated the features of in the, conventional inverter interfacing renewable with the grid, without any additional hardware cost. Here, the main idea is the maximum utilization of inverter rating which is most of the time underutilized due to intermittent nature of RES. It is shown in this paper that the grid-interfacing inverter with fuzzy logic control technique can effectively be utilized to perform following important functions: 1) Transfer active power harvested from the renewable resources (wind, solar, etc.). 2) Load reactive power demand support. 3) Current harmonics compensation at PCC. 4) Current unbalance and neutral current compensation in case of 3-phase 4-wire system. Moreover, with adequate control of grid-interfacing inverter, all the four objectives can be accomplished either individually or simultaneously.

## II. Proposed Concept

A proposed converter consists of a two-level VSC, a dc energy storage device, controller and a coupling transformer\ connected in shunt to the distribution network. Fig. 2.1shows the schematic diagram of proposed converter.

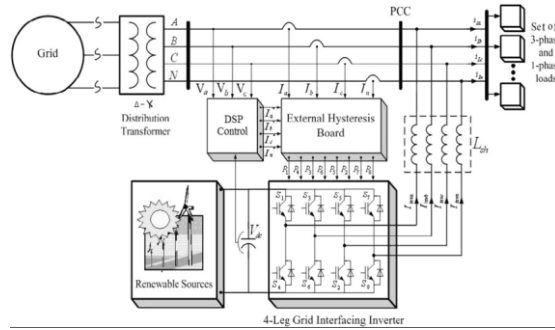


Fig.2. Schematic diagram of a proposed converter with RES.

**A. Voltage Source Converter (VSC):** A voltage-source converter is a power electronic device that connected in shunt or parallel to the system. It can generate a sinusoidal voltage with any required magnitude, frequency and phase angle. The VSC used to either completely replace the voltage or to inject the ‘missing voltage’. The ‘missing voltage’ is the difference between the nominal voltage and the actual. It also converts the DC voltage across storage devices into a set of three phase AC output voltages. In addition, Proposed Converter is also capable to generate or absorbs reactive power. If the output voltage of the VSC is greater than AC bus terminal voltages, proposed converter is said to be in capacitive mode. So, it will compensate the reactive power through AC system and regulates missing voltages. These voltages are in phase and coupled with the AC system through the reactance of coupling transformers. Suitable adjustment of the phase and magnitude of the proposed converter output voltages allows effectives control of active and reactive power exchanges between proposed converter and AC system. In addition, the converter is normally based on some kind of energy storage, which will supply the converter with a DC voltage.

**B. Controller for proposed converter:** The three-phase reference source currents are computed using three-phase AC voltages (vat, stand vtc) and DC bus voltage (Vdc) of proposed converter. These reference supply currents consist of two components, one in-phase (Ispdr) and another in quadrature (Ispqr) with the supply voltages. The control scheme is represented in Fig. 2. The basic equations of control algorithm of proposed converter are as follows.

### B1.Computation of in-phase components of reference supply current

The instantaneous values of in-phase component of reference supply currents (Ispdr) is computed using one PI controller over the average value of DC bus voltage of the proposed converter (vdc) and reference DC voltage (vdcr) as

$$I_{spdr} = I_{spdr(n-1)} + K_{pd} \{V_{de(n)} - V_{de(n-1)}\} + K_{id} V_{de(n)}$$

Where  $V_{de(n)} = \frac{1}{3}(V_{dca} + V_{dcb} + V_{dcd})$  denotes the error in Vdcccand average value of VdcKpdand Kid are proportional and integral gains of the DC bus voltage PI controller. The output of this PI controller (Ispdr) is taken as amplitude of in-phase component of the reference supply currents. Three-phase in-phase components of the reference supply currents (isadr, isbdr and iscdr) are computed using the in-phase unit current vectors (ua, uband uc) derived from the AC terminal voltages (vtan, vtbn and vtcn), respectively.

$$U_a = V_{ta}/V_{tm} \quad U_b = V_{tb}/V_{tm} \quad U_c = V_{tc}/V_{tm}$$

Where Vtm is amplitude of the supply voltage and it is computed as

$$V_{tm} = \sqrt{[(2/3)(V_{tan}^2 + V_{tbn}^2 + V_{tcn}^2)]}$$

The instantaneous values of in-phase component of reference supply currents (isa dr, is bdr and isc dr) are computed as

$$I_{sadr} = I_{spds} U_a \quad I_{sbdr} = I_{spdr} U_b \quad I_{scdr} = I_{spdr} U_c$$

### B2. Computation of quadrature components of reference supply current:

The amplitude of quadrature component of reference supply currents is computed using a second PI controller over the amplitude of supply voltage (vtm) and its reference value (vtmr)

$$I_{spqr(n)} = I_{spqr(n-1)} + K_{pq} \{V_{ac(n)} - V_{ac(n-1)}\} + K_{iq} V_{ac(n)}$$

Where  $V_{ac} = V_{tmc} - V_{mnc(n)}$  denotes the error in Vtmc and computed value Vtmn from Equation (3) and Kpq and Kiqare the proportional and integral gains of the second PI controller.

$$W_a = \{-U_b + U_c\}/\{\sqrt{3}\}$$

$$W_b = \{U_a\sqrt{3} + U_b - U_c\}/\{2\sqrt{3}\}$$

$$W_c = \{-U_a\sqrt{3} + U_b - U_c\}/\{2\sqrt{3}\}$$

Three-phase quadrature components of the reference supply currents (isaqr, isbqrand iscq) are computed using the output of second PI controller (Ispqr) and quadrature unit current vectors (wa, wband wc) as

$$i_{saqr} = I_{spqr} W_a, i_{sbqr} = I_{spqr} W_b, i_{scqr} = I_{spqr} W_c,$$

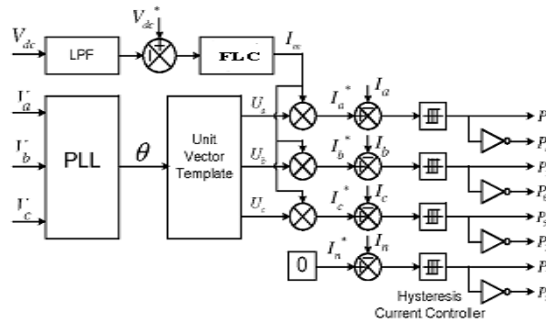


Fig.3 A FLC Control method for proposed converter

**B3 Computation of total reference supply currents:** Three-phase instantaneous reference supply currents (isar, isbrand iscr) are computed by adding in-phase (isadr, isbdrand iscdr) and quadrature components of supply currents (isaqr, isbqr and iscq) as

$$i_{sar} = i_{sadr} + i_{saqr}, \quad i_{sbr} = i_{sbdr} + i_{sbqr}, \quad i_{scr} = i_{scdr} + i_{scqr}$$

A hysteresis pulse width modulated (PWM) current controller is employed over the reference (isar, isbrand iscr) and sensed supply currents (isa, isband isc) to generate gating pulses for IGBTs of proposed converter.

### III. Introduction To Fuzzy Logic Controller

A new language was developed to describe the fuzzy properties of reality, which are very difficult and sometime even impossible to be described using conventional methods. Fuzzy set theory has been widely used in the control area with some application to dc-to-dc converter system. A simple fuzzy logic control is built up by a group of rules based on the human knowledge of system behavior. Matlab/Simulink simulation model is built to study the dynamic behavior of converter.

Furthermore, design of fuzzy logic controller can provide desirable both small signal and large signal dynamic performance at same time, which is not possible with linear control technique. Thus, fuzzy logic controller has been potential ability to improve the robustness of converters. The basic scheme of a fuzzy logic controller is shown in Fig 4 and consists of four principal components such as:

A fuzzy fiction interface, which converts input data into suitable linguistic values; a knowledge base, which consists of a data base with the necessary linguistic definitions and the control rule set,

A decision-making logic which, simulating a human decision process, infer the fuzzy control action from the knowledge of the control rules and linguistic variable definitions; a de-fuzzification interface which yields non fuzzy control action from an inferred fuzzy control action. The fuzzy control systems are based on expert knowledge that converts the human linguistic concepts into an automatic control strategy without any complicated mathematical model [10].

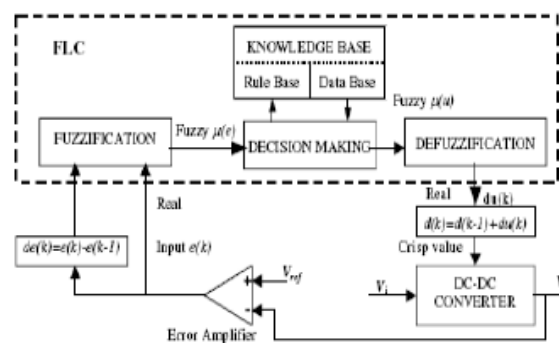


Fig.5. Block diagram of the Fuzzy Logic controller (FLC) for proposed converter

#### IV. Matlab/Simulink Modeling Of Proposed Converter,

##### A. Modeling of power circuit:

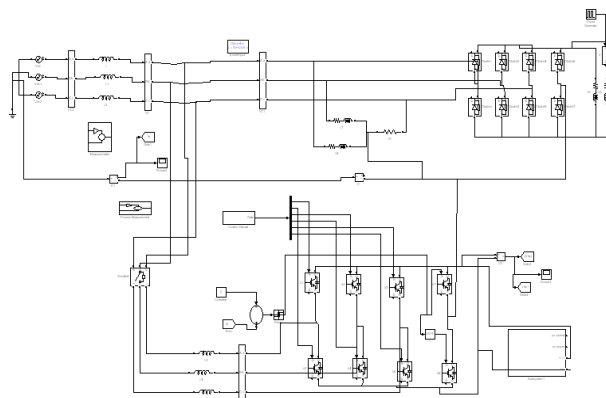


Fig..6 Mat lab/Simulink Model of Proposed

Fig. 6 shows the complete MATLAB model of proposed power circuit along with control circuit. The power circuit as well as control system are modeled using Power System Block set and Simulink. The grid source is represented by three-phase AC source. Three-phase AC loads are connected at the load end. Converter is connected in shunt and it consists of PWM voltage source inverter circuit and a DC capacitor connected at its DC bus. An IGBT-based PWM inverter is implemented using Universal bridge block from Power Electronics subset of PSB. Snubber circuits are connected in parallel with each IGBT for protection. Simulation of proposed system is carried out for non-linear load. The non-linear load on the system is modeled using R and R-C circuits connected at output of the diode rectifier. Provision is made to connect loads in parallel so that the effect of sudden load addition and removal is studied. The feeder connected from the three-phase source to load is modeled using appropriate values of resistive and inductive components.

##### B. Modeling of Control Circuit using fuzzy logic controller:

Fig. 7 shows the control algorithm of proposed converter with fuzzy logic controller. Fuzzy logic controller regulates the DC link voltage. The in-phase components of inverter reference currents are responsible for power factor correction of load and the quadrature components of supply reference currents are to regulate the AC system voltage at PCC.

The output of fuzzy logic controller over the DC bus voltage ( $I_{spdr}$ ) is considered as the amplitude of the in-phase component of supply reference currents and the output of fuzzy controller over AC terminal voltage ( $I_{spqr}$ ) is considered as the amplitude of the quadrature component of supply reference currents. The instantaneous reference currents ( $i_{sar}$ ,  $i_{sbr}$  and  $i_{scr}$ ) are obtained by adding the in-phase supply reference currents ( $i_{sadr}$ ,  $i_{sbrdr}$  and  $i_{scdr}$ ) and quadrature supply reference currents ( $i_{saqr}$ ,  $i_{sbqr}$  and  $i_{scqr}$ ). Once the reference supply currents are generated, a carrier less hysteresis PWM controller is employed over the sensed supply currents ( $i_{sa}$ ,  $i_{sb}$  and  $i_{sc}$ ) and instantaneous reference currents ( $i_{sar}$ ,  $i_{sbr}$  and  $i_{scr}$ ) to generate gating pulses to the IGBTs of converter. The controller controls the converter currents to maintain supply currents in a band around the desired reference current values. The hysteresis controller generates appropriate switching pulses for six IGBTs of the VSI working as converter.

##### A.Fuzzy Logic Membership Functions:

Fuzzy controllers do not require an exact mathematical model. Instead, they are designed based on general knowledge of the plant. Fuzzy controllers are designed to adapt to varying operating points. Fuzzy Logic Controller is designed to control the change in voltage of the converter using Mamdani style fuzzy inference system. Two input variables, error ( $e$ ) and change of error ( $de$ ) are used in this fuzzy logic system. The single output variable ( $u$ ) is steady state signal of the converter, nothing but error free response is directly fed to the system.

##### a.Fuzzy Logic Rules

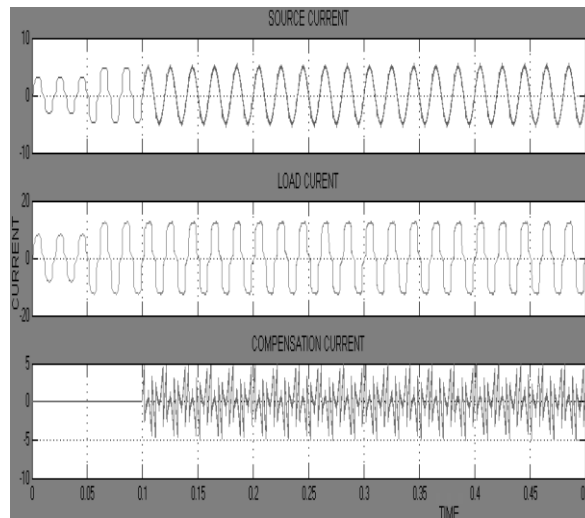
The objective of this dissertation is to control the output voltage of the boost converter. The error and change of error of the output voltage will be the inputs of fuzzy logic controller. These 2 inputs are divided into seven groups; NL: Negative Large, NM: Negative Medium, NS: Negative Small, ZO: Zero Area, PS: Positive small, PM: Positive Medium and PL: Positive Large and its parameter [10]. These fuzzy control rules for error and change of error can be referred that is shown as below:



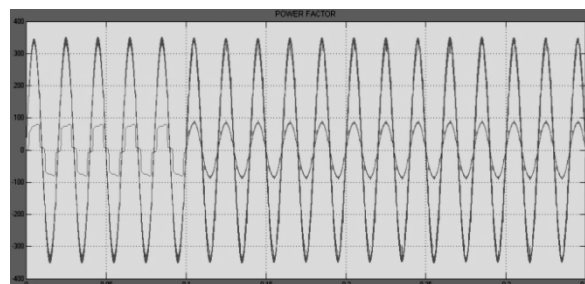
### V. Simulation Results

Here the simulation is carried out in two cases 1.Implementation of proposed converter using conventional PI controller. 2. Implementation of proposed converter using fuzzy logic controller.

**Case 1:** Implementation of proposed converter using conventional PI controller with PV model. Performance of proposed converter connected to a weak supply system is shown in Fig.5 for power factor correction and load balancing. This Fig. shows variation of performance variables such as supply voltages (vsa, vsband vsc), terminal voltages at PCC (vta, vtband vtc), supply currents (isa, isband isc), load currents (ila, ilband ilc), inverter currents (ica, icband icc) and DC link voltage (Vdc).

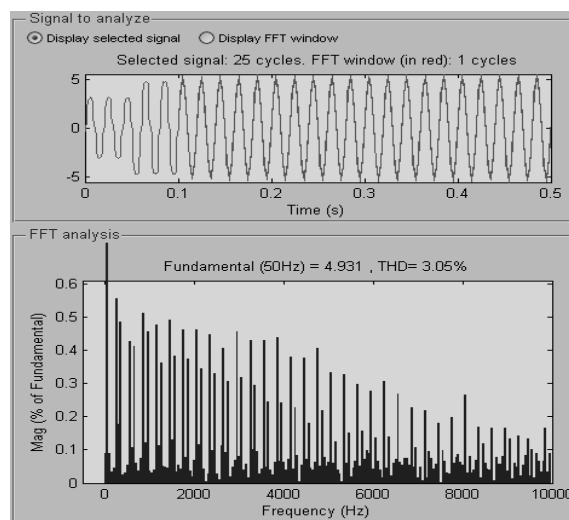


**Fig.10 .** Simulation results for Un Balanced Non Linear Load using PI controller (a) Source current. (b) Load current. (c) Inverter injected current.



**Fig.11:** Simulation power factor for unbalanced nonlinear load.

From the above Fig. it is clear that inverter is compensating both active and reactive power.



**Fig.13.** THD for inverter using PI controller it shows the THD analysis of the source current using the PI controller, we get 3.05%.

Case 2: Implementation of proposed converter using fuzzy logic controller:



Fig:14. Simulation results for Un Balanced Non Linear Load using fuzzy controller (a) Source current. (b) Load current. (c) Inverter injected current.

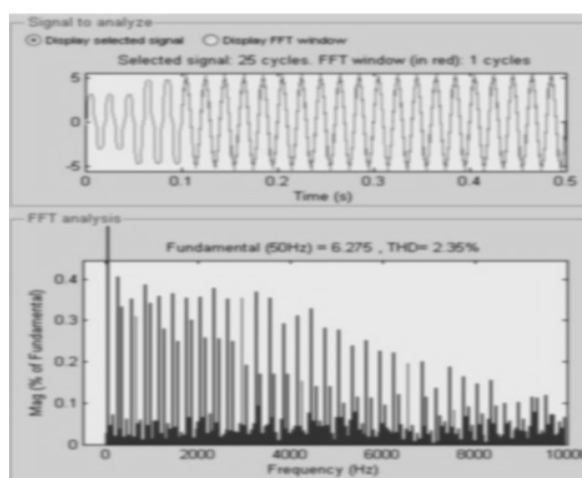


Fig.15 THD for inverter using fuzzy controller it shows the THD analysis of the source current using the fuzzy controller, we get 2.35%.

## VI. Conclusion

A control algorithm for a power filter constituted by a shunt active filter is connected in parallel with the load is proposed. The control strategy is based on the unit vector template for generate the reference currents and is proposed with different controller strategies. The new control approach achieves the following targets. Therefore, with the proposed control algorithm, the active filter improves the harmonic compensation features of the passive filter and the power factor of the load. This paper has presented a novel control of an existing grid interfacing inverter using conventional PI controller & fuzzy logic controller to improve the quality of power at PCC for a 3-phase 4-wire DG system. Proposed compensator is a flexible device which can operate in current control mode for compensating voltage variation, unbalance and reactive power and in voltage control mode as a voltage stabilizer. The simulation results show that the performance of converter system has been found to be satisfactory for improving the power quality at the consumer premises. By using conventional controller we get THD value is 3.05%, but using the fuzzy logic controller THD value is 2.35%. Finally Mat lab/Simulink based model is developed and simulation results are presented.

## References

- [1]. A.E. Hammad, Comparing the Voltage source capability of Present and future Var Compensation Techniques in Transmission System, IEEE Trans, on Power Delivery .volume 1. No.1 Jan 1995.
- [2]. G.Yalienkaya, M.H.J Bollen, P.A. Crossley, "Characterization of Voltage Sags in Industrial Distribution System", IEEE transactions on industry applications, volume 34, No. 4, July/August, PP.682-688, 1999.

- [3]. Haque, M.H., "Compensation Of Distribution Systems Voltage sags by DVR and D-STATCOM", Power Tech Proceedings, 2001 IEEE Porto, Volume 1, PP.10-13, September 2001.
- [4]. Anaya-Lara O, Acha E., "Modeling and Analysis Of Custom Power Systems by PSCAD/EMTDC", IEEE Transactions on Power Delivery, Volume 17, Issue: 2002, Pages: 266-272.
- [5]. Bollen, M.H.J., "Voltage sags in Three Phase Systems", Power Engineering Review, IEEE, Volume 21, Issue: 9, September 2001, PP: 11-15.
- [6]. M.Madrigal, E.Acha "Modelling of Custom Power Equipment Using Harmonics Domain Techniques", IEEE 2000.
- [7]. R.Meinski, R.Pawelek and I.Wasiak, "Shunt Compensation For Power Quality Improvement Using a STATCOM controller Modelling and Simulation", IEEE Proce, Volume 151, No. 2, March 2004.
- [8]. J.Nastran , R. Cajhen, M. Seliger, and P.Jereb,"Active Power Filters for Nonlinear AC loads, IEEE Trans.on Power Electronics Volume 9, No.1, PP: 92-96, Jan 2004.
- [9]. L.A.Moran, J.W. Dixon, and R.Wallace, A Three Phase Active Power Filter with fixed Switching Frequency for Reactive Power and Current Harmonics Compensation, IEEE Trans. On Industrial Electronics. Volume 42, PP: 402-8, August 1995.
- [10]. N.F Nik Ismail, I. Musirin, R. Baharom, D.Johari" Fuzzy Logic Controller on DC/DC Boost Converter" 2010 IEEE International Conference on Power and Energy (PECon2010), Nov 29 - Dec 1, 2010, Kuala Lumpur, Malaysia.
- [11]. L.T. Moran, P.DZiogas, and G.Joos, Analysis and Design of Three Phase Current source solid State Var Compensator, IEEE Trans, on Indutry Applications. Volume 25, No.2, 1989, PP: 356-65.