

Performance of Buck-Boost Converter with Mode Select Circuit and Feed Forward Technique

P.Harikumar¹, K.Palanivel rajan²

^{1,2}Anna University Chennai, 600 025, India

^{1,2}Department of Electrical & Electronics Engineering,

^{1,2}PSNA College of Engineering & Technology, Dindigul – 624 622, Tamilnadu, India.

Abstract: DC-DC converter topologies, the controllable switches are operated in switch mode where they are required to turn the entire load current on and off during each switching cycle. This work proposes a high-efficiency positive buck–boost converter with mode-select circuits and feed-forward techniques. Four power transistors produce more conduction and more switching losses when the positive and negative buck–boost converter operates in buck–boost mode. Utilizing the mode-select circuit, the proposed converter can decrease the loss of switches and let the positive buck–boost converter operate in buck, buck–boost, or boost mode. By adding feed-forward techniques, similarly for the proposed converter can improve transient response when the supply voltages are changed. The positive and negative feed forward technique of the buck boost converter is to be compared. The analysis and design method of the proposed work is carried out using MATLAB/ Simulink. PI controller is controlled using ABC algorithm.

Index Terms: DC-DC converter, Positive output Buck-Boost converter, Proportional-Integral (PI) control.

I. Introduction

DC-DC converter is commonly used to convert from one DC voltage level (often unregulated) to another regulated DC voltage level. Depending on the converters configuration, the resulting output voltage can be a step-up or step-down function of the input voltage and can appear as a positive or negative voltage to the load. The first method of changing DC voltages were simple voltage divider circuits, however these produced poor efficiency and were only suitable when an output voltage lower than the input was required. DC-DC conversion is a technology that is progressing rapidly and has become a crucial part of power electronics. New topologies are created every year, and statistics show that there are more than 500 topologies created to date, their applications ranging from low voltage logic and electronic applications to high voltage conversion using power electronics on the national grid. The many advantages include high efficiency, small size, low cost, and simplistic design. Prior to DC-DC converters, changing voltage levels was mostly achieved using AC transformers, making the process costly and also inefficient due to the DC/AC and AC/DC conversion processes. High power transformers are large and heavy, making them not suitable for many applications (such as computers). Voltage regulators are often inefficient for high power applications, and lack flexibility.

DC-DC converters can either be linear or switch-mode regulators. Linear converters use a series transistor operating in its active region, therefore acting as a variable resistor to regulate the output. The disadvantage of this is that high conduction losses occur and this results in poor efficiency (typically 30-60%). While the switching losses in a switch mode converter a higher, the overall efficiency is increased as the conduction losses are reduced dramatically. Thus, despite the complex and high EMI (Electromagnetic Interference) invoked due to high frequency switching, these converters are dominantly used. There are several different types of DC-DC converters available, which can step-up, step down or do both. They all follow the similar principle of charging and discharging reactive elements into a load, controlling the levels of charge and consequently the output voltage by switching the DC supply in and out of the circuit at high frequencies. They include a free-wheeling diode to protect the switch from the inductors high reverse currents, and this also ensures that the generated inductor energy is applied to the load. Capacitors are connected in parallel with the load to filter output ripple and maintain a constant output voltage. To achieve step-up, step-down, positive or negative outputs, the same principles apply between the topologies only the component configuration is different. The most common configurations are the buck, boost and buck-boost converters.

II. POSITIVE BUCK BOOST CONVERTER AND ITS OPERATION

This converter can work as a buck converter or a boost converter depending on input–output voltages. The problem of output regulation with guaranteed transient performances for non-inverting buck–boost converter topology is discussed. Various digital control techniques are addressed, which can smoothly perform the transition job. In the first two modes, the operation principles are the same as those of the buck converter.

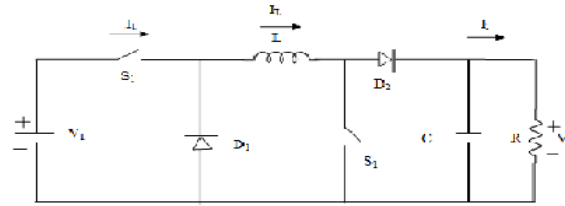

Fig.1.Positive output buck-boost converter

When the input voltage V_1 is higher than the output voltage V_2 the positive buck–boost converter can be operated in the “Buck Operation Mode.” In this case, the switch S_2 is constantly open, and the diode D_2 will be constantly on. The remaining components are the same as those of a buck converter. When the input voltage V_1 is lower than the output voltage V_2 the positive buck–boost converter can be operated in the “Boost Operation Mode.” In this case, the switch S_1 is constantly on, and the diode D_1 will be constantly blocked. When the input voltage V_1 is nearly equal to the output voltage V_2 the positive buck–boost converter can be operated in the “buck–boost operation mode.” In this case, both the switches S_1 and S_2 switch on and switch off simultaneously.

When the switches are on, the inductor current increases:

$$\Delta i_L = \frac{V_1}{L} kT \quad (1)$$

When the switches are off, the inductor current decreases:

$$\Delta i_L = \frac{V_1}{L} (1 - k) \quad (2)$$

Hence,

$$V_2 = \frac{k}{1 - k} V_1 \quad (3)$$

The basic operation of the buck boost converter is illustrated.

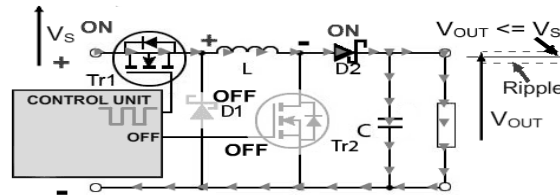

Fig.2.Operation as a Buck Converter during T_{r1} ‘on’ Period

The circuit operating as a Buck Converter. In this mode T_{r2} is turned off, and T_{r1} is switched on and off by a high frequency square wave from the control unit. When the gate of T_{r1} is high, current flows through L , charging its magnetic field, charging C and supplying the load. The Schottky diode D_1 is turned off due to the positive voltage on its cathode.

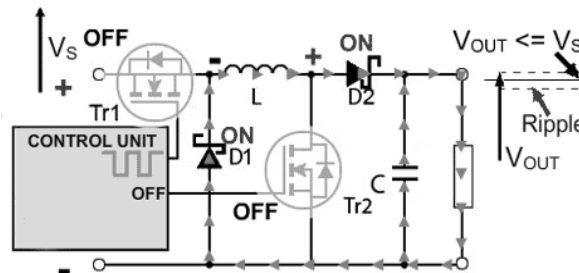

Fig.3.Operation as a Buck Converter during T_{r1} ‘off’ Period

The current flow during the buck operation of the circuit when the control unit switches T_{r1} off. The initial source of current is now the inductor L . Its magnetic field is collapsing, the back e.m.f. generated by the collapsing field reverses the polarity of the voltage across L , which turns on D_1 and current flows through D_2 and the load. As the current due to the discharge of L decreases, the charge accumulated in C during the on period of T_{r1} now also adds to the current flowing through the load, keeping V_{OUT} reasonably constant during the off period. This helps keep the ripple amplitude to a minimum and V_{OUT} close to the value of V_S .

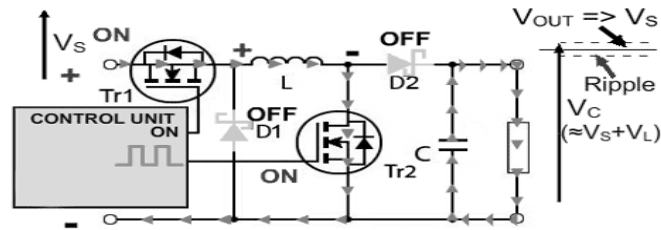

Fig.4.Operation as a Boost Converter during T_{r2} 'on' Period

In Boost Converter mode, Tr_1 is turned on continually and the high frequency square wave applied to Tr_2 gate. During the on periods when Tr_2 is conducting, the input current flows through the inductor L and via Tr_2 , directly back to the supply negative terminal charging up the magnetic field around L . whilst this is happening D_2 cannot conduct as its anode is being held at ground potential by the heavily conducting Tr_2 . For the duration of the on period, the load is being supplied entirely by the charge on the capacitor C , built up on previous oscillator cycles. The gradual discharge of C during the on period (and its subsequent recharging) accounts for the amount of high frequency ripple on the output voltage, which is at a potential of approximately $V_s + V_L$.

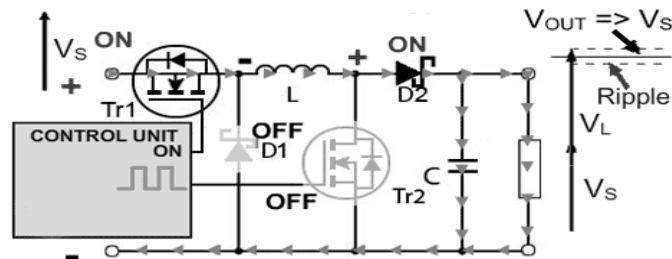

Fig.5.Operation as a Boost Converter during Tr_2 'off' Period

At the start of the off period of T_{r2} , L is charged and C is partially discharged. The inductor L now generates a back e.m.f. and its value that depends on the rate of change of current as T_{r2} switches off and on the amount of inductance the coil possesses; therefore the back e.m.f can be any voltage over a wide range, depending on the design of the circuit. Notice particularly that the polarity of the voltage across L has now reversed, and so adds to the input voltage V_s giving an output voltage that is at least equal to or greater than the input voltage. D_2 is now forward biased and so the circuit current supplies the load current, and at the same time re-charges the capacitor to $V_s + V_L$ ready for the next on period of T_{r2} .

III.DESIGN OF PI CONTROL

PI controller is a well-known controller which is used in the most application. PI controller becomes a most popular industrial controller due to its simplicity and the ability to tune a few parameters automatically. As an example for the application of PI controller in industry, slow industrial process can be pointed; low percentageovershoot and small settling time can be obtained by using this controller

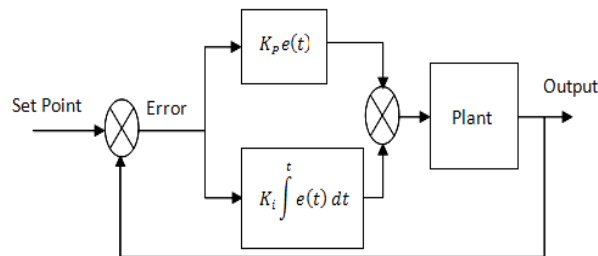

Fig.6. Structure of PI controller

PI most widely-used type of controller for industrial applications and exhibit robust performance over a wide range of operating conditions. The parameters involved are Proportional (P) and Integral (I). Fig.5.1 show the basic structure of PI controller. The proportional part is responsible for following the desired set-point, while the integral part account for the accumulation of past errors and the rate of change of error in the process respectively. In spite of simplicity, they can be used to solve even a very complex control problem, especially when combined with different functional blocks, filters (compensators or correction blocks), selectors etc.

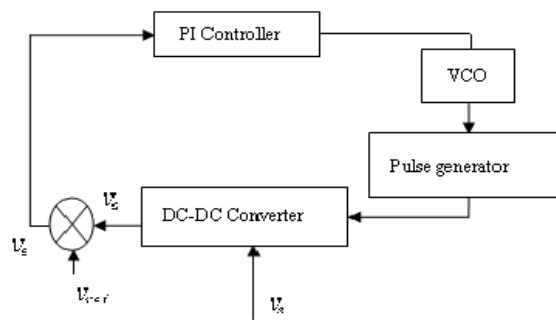

Fig.7. Block diagram of PI control for P/N DC-DC converter

PI control is designed to ensure the specifying desired nominal operating point. The PI control settings proportional gain (k_p) and (k_i) are designed using artificial bee colony algorithm which is the best optimization technique. In artificial beecolony algorithm bee represents a potential solution to the design problem which has a fitness value. In a real bee colony, some tasks are performed by specialized individuals. These specialized bees try to maximize the nectar amount stored in the hive using efficient division of labour and self-organization. The Artificial Bee Colony (ABC) algorithm, proposed by Karaboga in 2005 for real-parameter optimization, is a recently introduced optimization algorithm which simulates the foraging behaviour of a bee colony. The minimal model of swarm-intelligent forage selection in a honey bee colony which the ABC algorithm simulates consists of three kinds of bees: employed bees, onlooker bees and scout bees. Half of the colony consists of employed bees, and the other half includes onlooker bees. Employed bees are responsible for exploiting the nectar sources explored before and giving information to the waiting bees (onlooker bees) in the hive about the quality of the food source sites which they are exploiting. Onlooker bees wait in the hive and decide on a food source to exploit based on the information shared by the employed bees. Scouts either randomly search the environment in order to find a new food source depending on an internal motivation or based on possible external clues.

1. At the initial phase of the foraging process, the bees start to explore the environment randomly in order to find a food source.
2. After finding a food source, the bee becomes an employed forager and starts to exploit the discovered source. The employed bee returns to the hive with the nectar and unloads the nectar. After unloading the nectar, she can go back to her discovered source site directly or she can share information about her source site by performing a dance on the dance area. If her source is exhausted, she becomes a scout and starts to randomly search for a new source.
3. Onlooker bees waiting in the hive watch the dances advertising the profitable sources and choose a source site depending on the frequency of a dance proportional to the quality of the source.

In the ABC algorithm proposed by Karaboga, the position of a food source represents a possible solution to the optimization problem, and the nectar amount of a food source corresponds to the profitability (fitness) of the associated solution. Each food source is exploited by only one employed bee. In other words, the number of employed bees is equal to the number of food sources existing around the hive (number of solutions in the population). The employed bee whose food source has been abandoned becomes a scout. If the search space is considered to be the environment of the hive that contains the food source sites, the algorithm starts with randomly producing food source sites that correspond to the solutions in the search space. Initial food sources are produced randomly within the range of the boundaries of the parameters.

$$X_{ij} = X_{ij}^{min} + rand(0,1)(X_{ij}^{max} - X_{ij}^{min}) \quad (4)$$

Where $i=1\dots SN$, $j=1\dots D$. SN is the number of food sources and D is the number of optimization parameters. In addition, counters which store the numbers of trials of solutions are reset to 0 in this phase. After initialization, the population of the food sources (solutions) is subjected to repeat cycles of the search processes of the employed bees, the onlooker bees and the scout bees. Termination criteria for the ABC algorithm might be reaching a maximum cycle number (MCN) or meeting an error tolerance (ϵ).

As mentioned earlier, each employed bee is associated with only one food source site. Hence, the number of food source sites is equal to the number of employed bees. An employed bee produces a modification on the position of the food source (solution) in her memory depending on local information (visual information) and finds a neighbouring food source, and then evaluates its quality. In ABC, finding a neighbouring food source is defined below.

$$V_{ij} = X_{ij} + \varphi_{ij}(X_{ij} - X_{kj}) \quad (5)$$

Table 1

Pseudo-code of the ABC algorithm is:

1. Load training samples
2. Generate the initial population $Z_i, i=1..SN$
3. Evaluate the fitness (f_i) of the population
4. Set cycle to 1
5. **repeat**
6. **for** each employed bee{
Produce new solution v_i by using (6)
Calculate the value f_i
Apply greedy selection process}
7. Calculate the probability values p_i for the solutions(z_i) by (5)
8. **For** each onlooker bee{
select a solution z_i depending on p_i
Produce new solution v_i
Calculate the value f_i
Apply greedy selection process}
9. **If** there is an abandoned solution for the scout
Then replace it with a new solution which will be randomly produced by (7)
10. Memorize the best solution so far
11. cycle=cycle+1
12. **until** cycle=MCN

IV. SIMULATION STUDY

The simulation results for Positive output buck boost converter using PI controller tuned with soft computing techniques such as Artificial bee colony algorithm have been presented.

AI technique	Proportionality constant(k_p)	Integral constant(k_i)
ABC	2.055	12.06

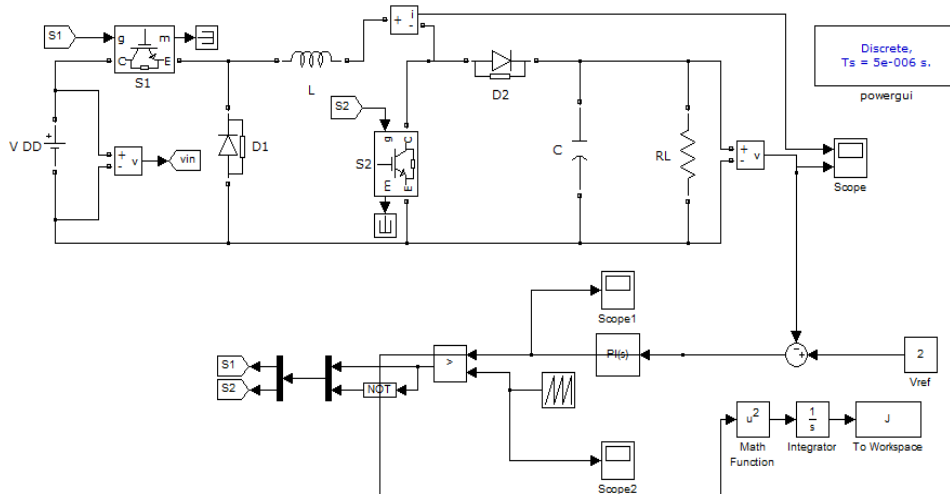

Fig.8. Simulink model for Proposed positive output Buck-Boost Converter

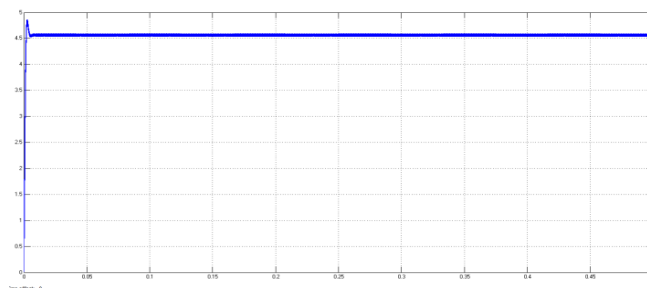

Fig.9. Simulated Response of Voltage waveform for setvalue of 4.6

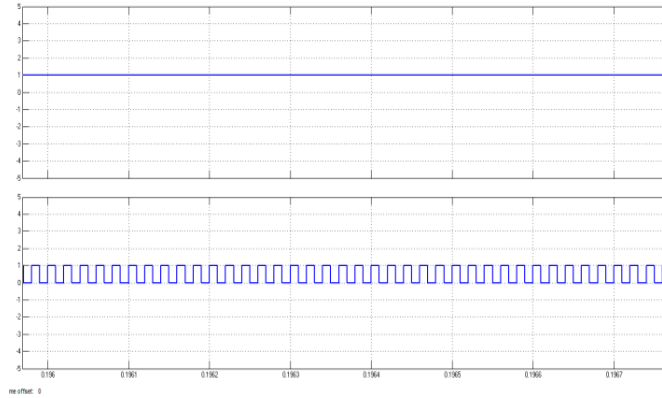

Fig.10. Simulated Response of GATE PULSES FOR S_1 & S_2

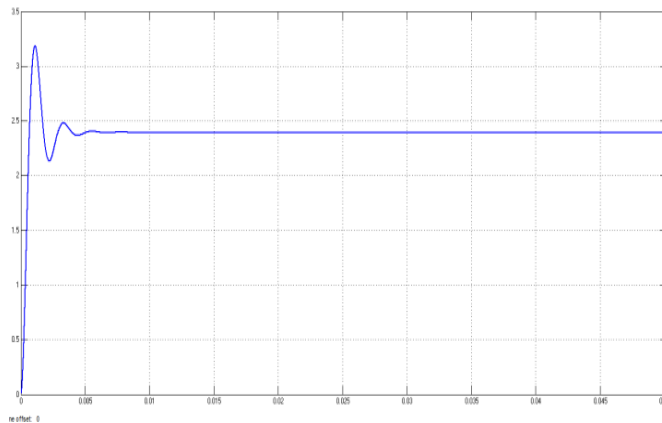

Fig.11. Simulated Response of Voltage waveform for set value of 2.4 V

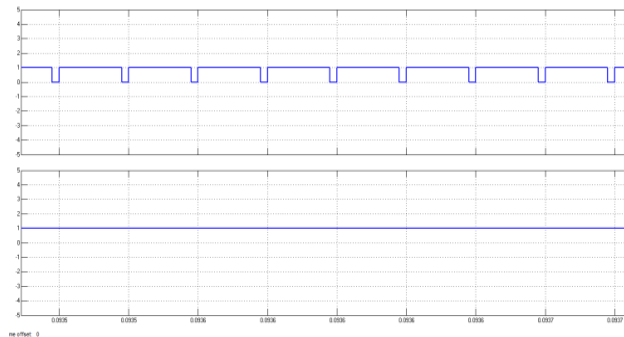

Fig.12. Simulated Response of GATE PULSES FOR S_1 & S_2

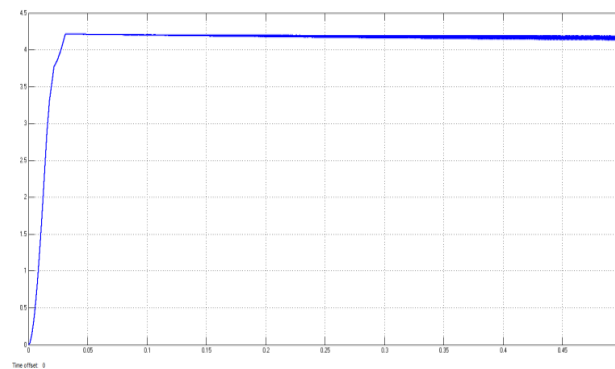

Fig.13. Simulated Response of Voltage waveform for set value of 4.1 V

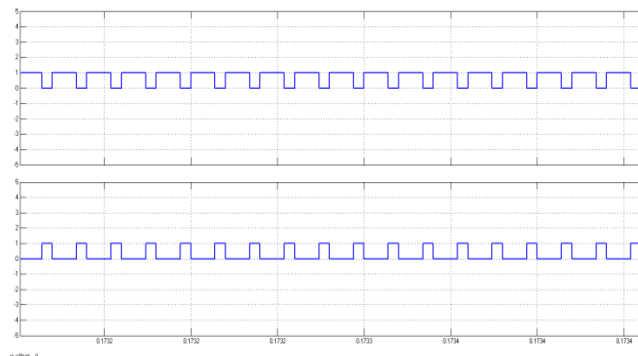

Fig.14. Simulated Response of GATE PULSES FOR S_1 & S_2

V. CONCLUSION

Due to the time variations and switching nature of power converters, their dynamic behavior becomes highly non-linear. This work has successfully demonstrated the design, analysis and suitability of PI controlled positive output buck boost converter. PI control with soft computing techniques such as artificial bee colony algorithm has proved to be robust and suited for line and load disturbances. Among the soft computing technique it is seen that ABC possess best result.

REFERENCES

- [1] Jiann-Jong Chen, Pin-Nan Shen, and Yuh-Shyan Hwang, "A High-Efficiency Positive Buck-Boost Converter With Mode-Select Circuit and Feed-Forward Techniques," *IEEE transactions on power electronics*, vol. 28, no. 9, september 2013.
- [2] S. Maity and Y. Suraj, "Analysis and modeling of an FFHC-controlled dc-dc buck converter suitable for wide range of operating conditions," *IEEE Trans. Power Electron.*, vol. 27, no. 12, pp. 4914–4924, Dec. 2012.
- [3] R. Guo, Z. Liang, and A. Q. Huang, "A family of multimodes charge pump based dc-dc converter with high efficiency over wide input and output range," *IEEE Trans. Power Electron.*, vol. 27, no. 11, pp. 4788–4798, Nov. 2012.
- [4] P.-J. Liu, J.-N. Tai, H.-S. Chen, J.-H. Chen, and Y.-J. E. Chen, "Spurred reduction design of frequency-hopping dc-dc converters," *IEEE Trans. Power Electron.*, vol. 27, no. 11, pp. 4763–4771, Nov. 2012.
- [5] C. Restrepo, J. Calvente, A. Romero, E. Vidal-Idiarte, and R. Giral, "Current-mode control of a coupled-inductor buck-boost dc-dc switching converter," *IEEE Trans. Power Electron.*, vol. 27, no. 5, pp. 2536–2549, May 2012.
- [6] K. K. I. Hwu and T. T. J. Peng, "A novel buck-boost converter combining KY and buck converters," *IEEE Trans. Power Electron.*, vol. 27, no. 5, pp. 2236–2241, May 2012.
- [7] Y. Lee, S. Huang, S. Wang, W. Wu, P. Huang, H. Ho, Y. Lai, and K. Chen, "Power-tracking embedded buck-boost converter with fast dynamic voltage scaling for the SoC system," *IEEE Trans. Power Electron.*, vol. 27, no. 3, pp. 1271–1282, Mar. 2012. [8] C. Yao, X. Ruan, X. Wang, and C. K. Tse, "Isolated buck-boost dc/dc converters suitable for wide input-voltage range," *IEEE Trans. Power Electron.*, vol. 26, no. 9, pp. 2599–2613, Sep. 2011.
- [9] C. Restrepo, J. Calvente, A. Cid-Pastor, A. E. Aroudi, and R. Giral, "A noninverting buck-boost dc-dc switching converter with high efficiency and wide bandwidth," *IEEE Trans. Power Electron.*, vol. 26, no. 9, pp. 2490–2503, Sep. 2011.