

Demand Side Management Motor Control Using Multilevel Inverter

G. Saranraj¹, Mr. M. Sudhakaran, M. E, (Ph.D)², Dr. R. Seyezhai³

¹PG Scholar, Electrical & Electronics Eng., Ganadipathy Tulsi's Jain Engineering college, Kaniyambadi, Vellore – 632102.

²Associate professor, Electrical & Electronics Eng, Ganadipathy Tulsi's Jain Engineering college, Kaniyambadi, Vellore – 632102.

³Associate professor, Siva Subramani Nadar College of Engineering, Kalavakkam

Abstract: In this paper is to explain the unbalance electric scenario in the Power System. To explain how unbalance condition is one of the most important problems associated with power quality and creates several disturbances to the Power System. It includes the Harmonic reduction techniques to improve the power quality and it also includes the simulation for the same. This project presents a multilevel inverter topology suitable for the generation of 3 phase supply. A simple and fast carrier based Direct-torque control with pulse width modulation (PWM) scheme is also proposed for the topology which utilizes only the sampled amplitudes of the reference wave for the PWM timing computation. Individual independent inverter is combined to form the three phase output. Because of the loads are specific and it can be varied.

Index term: multilevel-inverter, PWM techniques, MSP 430 controller, Induction motor, V&I balanced condition.

I. Introduction

The concept of demand-side management (DSM) has been introduced in the USA more specifically in the electricity industry in the mid-eighties. It has been originally defined as the planning, implementation and monitoring of a set of programs and actions carried out by electric utilities to influence energy demand in order to modify electric load curves in a way which is advantageous to the utilities[1]. Changes in load curves must decrease electric systems running costs both production and delivery costs and also allow for deferring or even those avoiding some investments in supply-side capacity expansion. Thus, DSM has been driven by strict economic reasons. Energy efficiency was a privileged instrument for DSM implementation as will be seen Hence, in societal terms this was a typical win-win situation as consumers would also benefit from cheaper energy services as overall efficiency would increase[2].

DSM has been a major breakthrough that led to a great deal of innovation both at business management and at technological development and also to huge environmental benefits. Yet, a great number of DSM tools already existed previously to the concept and had been in use by many utilities namely those tools related to remote load control known as load management (LM)[3]. But LM aims predominantly at influencing power use the amount of energy used by unit of time at specific times. Energy efficiency was actually a new comer to the business brought by DSM to the port of utility management options. There are six main objectives defined in the context of DSM, known as: peak clipping, valley filling, load shifting, flexible load curve strategic conservation and strategic load growth[4]. Apart from strategic load growth (SLG), all other options require that the utility's system is under pressure and requires either capacity expansion or load relief[5]. Cost-benefit analysis will dictate which options to adopt In general, DSM implementation options may be classified into several different broad categories customer education, direct customer contact, trade co-operation advertising promotion, alternative pricing, direct incentives. Some measures pin-pointed in the text below are examples of some of them[6].

1.1 Problems Facing Utility-Driven Dsm

Influencing the way electric energy is used has become an effective means of complementing supply-side options with the purpose of increasing overall systems efficiency. Determining the appropriate mix of supply-side and demand-side resources became the goal of the so-called integrated resource planning (IRP), allegedly leading to a global least-cost approach[7]. Several difficulties had to be with to solve the problem of cost-benefit evaluation of demand-side options. A standard approach has been designed for the purpose which has only recently been adapted to the European specificities through an initiative of the European Commission 1996. DSM has been recognized as an ally to environment conservation as it leads normally to lower overall consumption growth and contributes to using available resources in a more rational way the portfolio.

The concept of demand-side management may, under these assumptions, be easily generalised. It may be driven by other agents besides energy suppliers -- namely governments and municipal authorities -- and may be understood broadly as a framework of actions and programmes aiming at energy efficiency improvement at the demand side. Ultimately, to comply with environmental protection The present trend towards energy market liberalisation brings about some concerns, as for instance on how to prevent utilities from keeping the old perspective of selling kilowatt-hours instead of energy services. Some authors express fears that DSM may be in danger when confronted with plain market rules taking into account that regulation has been indispensable to make it work up to now where it has been successful options[8] Huge savings, both financial, energy and environmental have been claimed, namely in the USA as due to the massive adoption of DSM programs by utilities, bounded by strict regulatory constraints.

1.2 Dsm Opportunities

Experience shows that in countries where liberalization is more advanced, utilities show a natural tendency towards maximizing profits and hence to promote energy sales. This is clearly at odds with energy efficiency promotion and led to the abandonment or in the best cases to a strong decrease of DSM utility-driven initiatives. A broader content has been proposed above for DSM which enlarges the list of actors with an active potential role in the promotion of energy efficiency authorities, utilities, consumers, energy service companies, equipment manufacturers.

The block diagram shown below displays the controller part, loads and inverter section of the system. The inverter is controlled by the msp430 microcontroller based on the feedback received from the loads connected to the inverter. The input signal for the inverter from the controller part will be varied based on the position of the load applied to the system. When normal load is applied (i.e. only one load is working) a normal pwm signal with fixed frequency level will be applied to the inverter which will generate the voltage that is sufficient to drive the single load when the load has been increased by adding one more load.

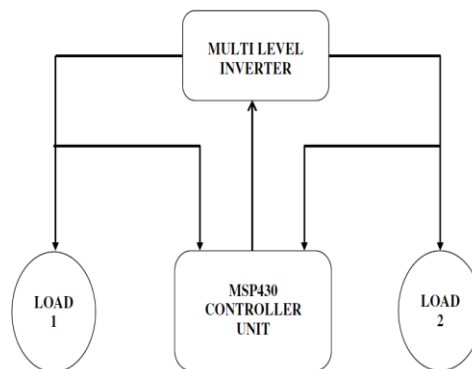

Fig1.block diagram

Generated from controller is increased to satisfy the power constrain in order to satisfy the demand side management the frequency has been changed the demand created as been satisfied The feedback from the load will be collected by the controller in order to maintain the demand side management in the system we created in both balanced and unbalanced criteria

II. Multilevel Inverter

Multi-level Inverters are a type of inverters whose construction is similar to the single and three phase inverters as explained earlier. The figure 2 shows a multi-level inverter which is an extension of single and three phase inverters. Here four IGBT circuits are connected in three different legs and the diodes are connected in parallel to each leg in opposite direction. Also, the loads are connected between two IGBT circuits for each leg. The traditional PWM methods employ much higher switching frequencies for two reasons. The first reason concerns harmonics. Undesirable harmonics occur at much higher frequencies. Thus, filtering is much easier and less expensive Furthermore, switching at the fundamental frequency will also result in decreasing the number of times these voltage changes occur per fundamental cycle. Due to the difficulty of solving the transcendental equations, real-time control of multilevel inverter with unequal DC voltages is impossible now.

2.1 Msp430 Control Unit

The MSP430 is perfect for low-power and super miniature projects. Not only are smaller circuit boards cheaper to make, but they are desirable in many applications; such as in wireless sensor nodes, wearable electronics, and others. Standard 0.1" headers are simply too big for very small boards. To reduce the size requirement for the programming header, I have started using 0.05" headers. With this post, I would like to share how I use smaller headers to easily make my projects smaller and more cost efficient. Due to how cheap the MSP430 Launch Pad is, it is often the best way to program your custom MSP430 boards. One of my earlier posts details how I using a 6 pin 0.1" header. It is important to me that I include both the UART RXD and TXD pins in the programming header for debugging purposes. The simple schematic is shown above. Using a 3x2 pin 0.05" header on the target board, I created a "converter" board which connects to the Launch Pad using a 6 pin 0.1" header. Additionally, if I want to reduce the footprint further, I can use only a single 3x1 pin 0.05" header, ignoring the VCC, RXD, and TXD pins (as long as the target device is self powered). The circuit is shown above. It is very simple, yet very effective.

2.2 Induction Motor

An induction or asynchronous motor is an AC electric motor in which the electric current in the rotor needed to produce torque is induced by electromagnetic induction from the magnetic field of the stator winding. An induction motor therefore does not require mechanical commutation, separate-excitation or self-excitation for all or part of the energy transferred from stator to rotor, as in universal, DC and large synchronous motors. An induction motor's rotor can be either wound type or squirrel-cage type. Three-phase squirrel-cage induction motors are widely used in industrial drives because they are rugged, reliable and economical. Single-phase induction motors are used extensively for smaller loads, such as household appliances like fans. Although traditionally used in fixed-speed service, induction motors are increasingly being used with variable-frequency drives (VFDs) in variable-speed service. Squirrel cage induction motors are very widely used in both fixed-speed and VFD applications.

2.3 Direct Torque Control (Dtc)

Direct torque control was developed by Takahashi and Demand as an alternative to field-oriented control DTC is a control philosophy exploiting the torque and flux producing capabilities of ac machines when fed by a simple voltage source inverter that does not require current regulation loops, still attaining similar performance to that obtained from a vector control drive. In a direct torque controlled (DTC) induction motor drive supplied by a voltage source inverter, it is possible to control directly the stator flux linkage and the electromagnetic torque by the selection of an optimum inverter voltage vector. The selection of the voltage vector of the voltage source inverter is made to restrict the flux and torque error within their respective flux and torque hysteresis bands and to obtain the fastest torque response and highest efficiency at every instant. DTC enables both quick torque response in the transient operation and reduction of the harmonic losses and acoustic noise. With DTC there is no modulator and no requirement for a tachometer or position encoder to feed back the speed or position of the motor shaft. In DC drive armature current and magnetizing current are control variables whereas in DTC, motor torque and motor magnetizing flux are control variable. Both drives use actual motor parameters to control torque and speed which shows better dynamic performance.

III. 5-level inverter

A five-level inverter-fed induction motor drive scheme is proposed in the present work for simultaneously achieving the dual task of elimination of common-mode voltage and DC-link capacitor voltage imbalances. The proposed scheme is based on a dual five-level inverter-fed open-end winding induction motor configuration. This paper investigates the operating limitations of achieving this dual task for the five-level inverter-fed drive with a single DC power supply. A five-level inverter-fed drive topology with two DC power supplies, and a strategy for selecting the switching states, are proposed to achieve the dual task simultaneously. The proposed inverter-fed drive offers a simple power bus structure with more redundant switching states for inverter voltage vectors, and demands a lower voltage blocking capacity of the power devices, as compared with a single five-level inverter-fed drive As only the availability of redundant switching states for the inverter. But for the active harmonic elimination method, if the harmonic equations have no solutions for a set of harmonics they may have solutions for other sets of harmonics. The cost is just additional switchings In addition, the switches may be chosen to charge or discharge the clamped capacitors, which balance the capacitor voltage.

3.1 Effects of different switching-state combinations on variation of capacitor voltages

For ease of analysis all the inverter voltage vectors of are divided into five main groups as shown in The effects of redundant switching-state combinations of voltage space vectors belonging to each of these groups on the charging and discharging of the DC-link capacitors are studied. Based on the connection of

machine phase winding terminals with the DC-link nodes, the currents drawn from the DC-link nodes to the machine phase windings and vice versa are assigned with proper signs, It is found for all the switching-state combinations of voltage that there is no flow of currents to or from any of the DC-link nodes as the motor phases are not connected across any of the capacitors.

IV. Simulation Result

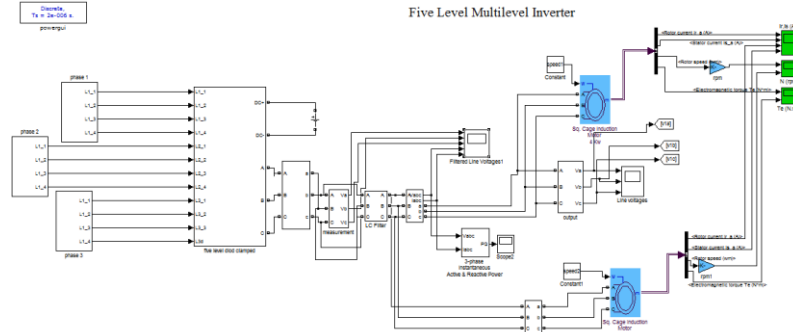

Fig 2. 5-level inverter circuit diagram

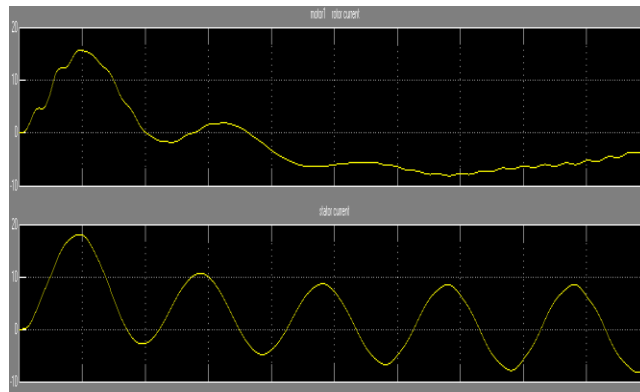

Fig 3. stator current & rotor current

Inverters using an induction motor configuration can realize multilevel inverter structures. The voltage across the phase winding of the induction motor can attain one of the five levels $-2V_{dc}$, $-V_{dc}$, $0, 2V_{dc}$ or V_{dc} , depending upon the switching states of the inverters. The switching combinations of inverter for realizing the different levels in the A phase of a three-level inverter with IM configuration are shown in Table II, where $S_{a1}, S_{a2}, S_{a3}, S_{a4}$ represent the top switches of Inverter and $S_{a5}, S_{a6}, S_{a7}, S_{a8}$ represents the bottom switches, respectively, for the A-phase. Equations are used to determine switching angles of an Inverter. In order to form the equation set, fundamental component is given desired output value and all other harmonics are equated to zero.

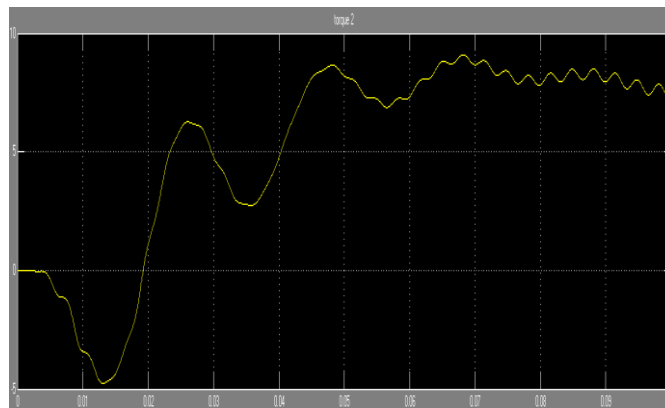

Fig 4. Torque

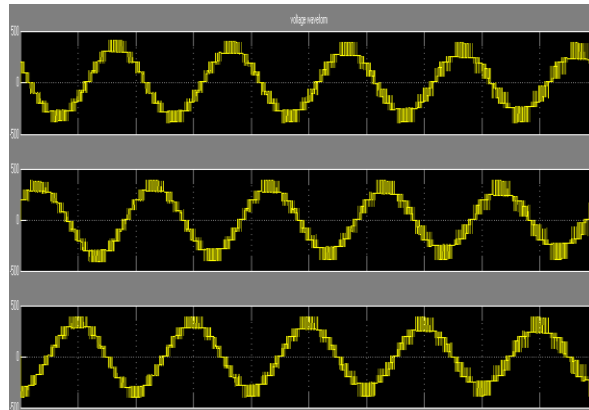

Fig 5. voltage waveform

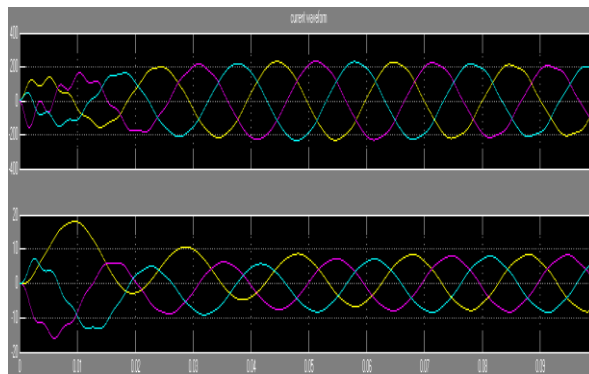

Fig 6. Current waveform

V. Total Harmonics Distortion

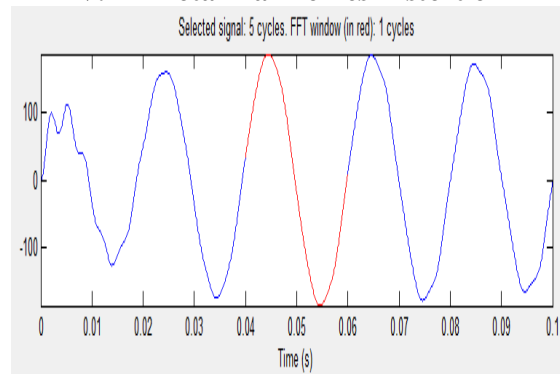

Fig 7. 5 level voltage THD

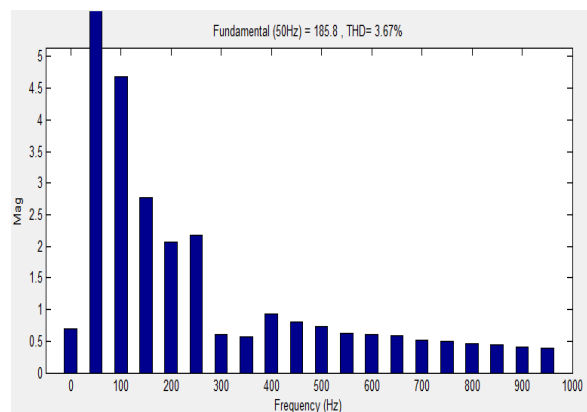

Fig 8. 5 level voltage THD

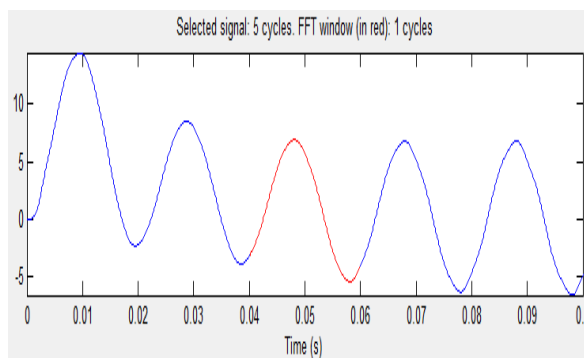

Fig 9. 5 level current THD

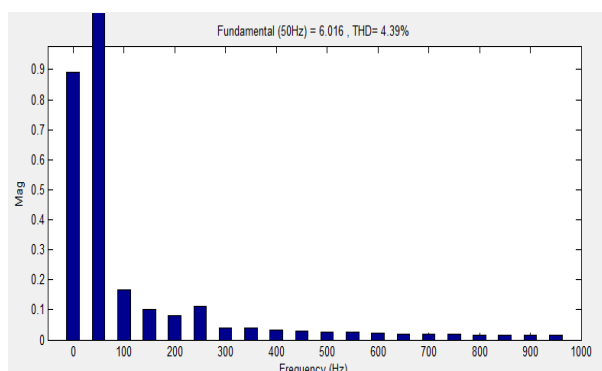

Fig 10. 5 level current THD

Comparison between voltage & current

5-level balanced condition (rpm)	Voltage THD	Current THD
1400,1400	3.67%	4.39%
1350,1300	4.31%	6.32%
1200,1100	3.20%	7.07%
1000,900	4.71%	1.90%
800,700	4.28%	0.99%

Table.1 voltage & current THD

This chapter shows how harmonic elimination is done in Inverter by Pulse Width Modulation technique by solving the non linear equations. Equations are used to determine switching angles of an Inverter. In order to form the equation set, fundamental component is given desired output value and all other harmonics are equated to zero. switching angles simulated for the 5-level harmonics. The equation which is derived for Total Harmonic Distortion of the output voltage of an inverter is used in order to reduce the harmonics that are produced in the inverter. The percentage of the Total Harmonic Distortion is given by the following formula. For different application requirements, we have different optimal goals. In both induction and synchronous motors, the AC power supplied to the motor's stator creates a magnetic field that rotates in time with the AC oscillations Whereas a synchronous motor's rotor turns at the same rate as the stator field, an induction motor's rotor rotates at a slower speed than the stator field.

The induction motor stator's magnetic field is therefore changing or rotating relative to the rotor. This induces an opposing current in the induction motor's rotor, in effect the motor's secondary winding, when the latter is short-circuited or closed through external impedance .The currents in the rotor windings in turn create magnetic fields in the rotor that react against the stator field. Due to Lenz's Law, the direction of the magnetic field created will be such as to oppose the change in current through the rotor windings.

The cause of induced current in the rotor windings is the rotating stator magnetic field, so to oppose the change in rotor-winding currents the rotor will start to rotate in the direction of the rotating stator magnetic field.The difference, or "slip," between actual and synchronous speed varies from about 0.5 to 5% for standard Design B torque curve induction motors. The induction machine's essential character is that it is created solely by induction instead of being separately excited as in synchronous or DC machines or being self-magnetized as in permanent magnet motors. For rotor currents to be induced, the speed of the physical rotor must be lower than that of the stator's rotating magnetic field (n_s). As the speed of the rotor drops below synchronous speed, the rotation rate of the magnetic field in the rotor increases, inducing more current in the windings and creating more

torque. For this reason, induction motors are sometimes referred to as asynchronous motors an induction motor can be used as an induction generator.

VI. Conclusion

A weighted direct torque control of speed-irrelevant dual induction motors fed by the multilevel inverter is proposed. The performance of balanced load control is improved by regulating the weight of the direct torque control. The weighted excitation current and torque current derived by the weighted vector mode can realize the torque control of speed-relevant dual induction motors and distribute the weight of direct torque control to dual induction motors. In heavy balanced load, the propose method completely distributes the weight of direct torque control to the induction motor at standstill to start at heavy balanced load effectively. From the simulation results, the THD obtained for balanced 3-phase induction motors are V-THD=3.67%, I-THD=4.39% the THD obtained are less when compare to unbalanced load 3phase dual induction motors.

Reference

- [1] "Multi-level conversion and voltage-source inverters high voltage choppers" t.a. meynard, h. foch 1992.
- [2] "Improved Method of Voltage Utility Factor for PWM Control Method of Five-Leg Inverter" Kazuo Oka* and Yusuke Nozaw
- [3] "Weighted Control of Traction Drives With Parallel-Connected AC Machines" Alain Bouscayrol, Phillipe Delarue, Paul-Etienne Vidal, Xavier Kestelyn 2011.
- [4] "A Novel Control Scheme of a Parallel Current-Controlled PWM Inverter" Satoshi Ogasawara Jin Takagaki, Hirofumi Magi september/October1992.
- [5] "Optimized modulation techniques for the generalized N-level converter" M. Fracchia, T. Ghiara, M. Marchesoni 1992.
- [6] "Characteristics of Independent Two Induction Motor Drives Fed by a Four-Leg Inverter" Kouki Matsuse, and Kazuo Oka 2011.
- [7] "A Stator-Flux-Based Vector Control Method for Parallel-Connected Multiple Induction Motors Fed by a Single Inverter" yasushi Matsumoto, Chiharu Osawa, Tetsuya Mizukami 1998.
- [8] "Characteristics of Speed Sensor less Vector Controlled Dual Induction Motor Drive Connected in Parallel Fed by a Single Inverter" Hirotohi Kawai, Yuusuke Kouno, and Jun Oikawa 2004.