

## **Artificial Intelligence Based Dynamic Simulation of Induction Motor Drives**

P. M. Menghal<sup>1</sup>, Dr. A. Jaya Laxmi<sup>2</sup>

<sup>1</sup>Faculty of Electronics, Military College of Electronics and Mechanical Engineering, Secunderabad - 500015, Andhra Pradesh, India

<sup>1</sup>Research Scholar, EEE Dept., Jawaharlal Nehru Technological University, Anantapur-515002, Andhra Pradesh, India

<sup>2</sup>Dept. of EEE, Jawaharlal Nehru Technological University, College of Engineering, Kukatpally, Hyderabad-500085, Andhra Pradesh, India

---

**Abstract:** Induction Motors have many applications in the industries, because of the low maintenance and robustness. The speed control of induction motor is more important to achieve maximum torque and efficiency. This paper presents an integrated environment for speed control of vector controlled Induction Motor (IM) including simulation. The integrated environment allows users to compare simulation results between classical and artificial intelligent controllers. In recent years, the field oriented control of induction motor drive is widely used in high performance drive system. It is due to its unique characteristics like high efficiency, good power factor and extremely rugged nature of Induction motor. The fuzzy logic controller and artificial neural network controllers are also introduced to the system for keeping the motor speed to be constant when the load varies. The speed control scheme of vector controlled induction motor drive involves decoupling of the speed and reference speed into torque and flux producing components. The performance of fuzzy logic and artificial neural network based controller's is compared with that of the conventional proportional integral controller. The dynamic modeling of Induction motor is done and the performance of the Induction motor drive has been analyzed for constant and variable loads.

**Keywords:** Dynamic Modeling, Fuzzy PI Controller, Artificial Neural Network, Vector Control

---

### **I. Introduction**

Induction Motors (IMs) have been used as the workhorse in industry for a long time due to their easy build, high robustness, and generally satisfactory efficiency [1]. The vector control technique, which is developed upon the field orientation principle proposed by Haase in 1968 and Blaschke in 1970, decouples the flux and torque control in an IM [2]. Thus, it makes the control task of IM drives similar to a separately excited DC motor while maintaining the general advantages of AC over DC motors and, hence, suitable for high-performance variable-speed drive applications, debated for a long time, and will possibly be debated forever. However, there is no denying the fact that computers can have adequate intelligence to help solving our problems that are difficult to solve by traditional methods. Therefore, it is true that AI techniques are now being extensively used in industrial process control, image processing, diagnostics, medicine, space technology and information management system, just to name a few. With the advent of recent power semiconductor technologies and various intelligent control algorithms, an effective control method based on vector control technology can be fully implemented in real-time application. Because of these facilities, nowadays, vector-control based high-performance IM drives have occupied most of the positions that were previously stationed by dc motor drives [2]. In recent years, scientists and researchers have acquired significant development on various sorts of control theories and methods. Among these control technologies, intelligent control methods, which are generally regarded as the aggregation of fuzzy logic control, neural network control, genetic algorithm, and expert system, have exhibited particular superiorities. Artificial Intelligent Controller (AIC) could be the best controller for Induction Motor control. Over the last two decades researchers have been working to apply AIC for induction motor drives [1-6]. This is because that AIC possesses advantages as compared to the conventional PI, PID and their adaptive versions. High accuracy is not usually imperative for most of the induction motor drive, however high performance IM drive applications, a desirable control performance in both transient and steady states must be provided even when the parameters and load of the motor varying during the operation. Controllers with fixed parameters cannot provide these requirements unless unrealistically high gains are used. Thus, the conventional constant gain controller used in the variable speed induction motor drives become poor when the uncertainties of the drive such as load disturbance,

mechanical parameter variations and unmodelled dynamics in practical applications. Therefore, control strategy must be adaptive and robust. As a result several control strategies have been developed for induction motor drives within last two decades. The Artificial Intelligence (AI) techniques, such as Expert System (ES), Fuzzy Logic (FL), Artificial Neural Network (ANN or NNW) and Genetic Algorithm (GA) have recently been applied widely in power electronics and motor drives. The goal of AI is to plant human or natural intelligence in a computer so that a computer can think intelligently like a human being. A system with embedded computational intelligence is often defined as an “intelligent system” that has “learning,” “self-organizing,” or “self-adapting” capability. Computational intelligence has been debated for a long time, and will possibly be debated forever. While Expert Systems (ES) and FL are rule-based, and tend to emulate the behavioral nature of human brain, the NNW is more generic in nature that tends to emulate the biological neural network directly. The history of NNW goes back to 1940s, but its advancement was camouflaged by the glamorous evolution of modern-day digital computers. From the beginning of 1990s, the NNW technology captivated the attention of a large segment of scientific community. Since then, the technology has been advancing rapidly and its applications are expanding in different areas. The GA theory (also known as evolutionary computation) was proposed in 1970s and it is based on principles of genetics (or Darwin’s survival of the fittest theory of evolution). Basically, it solves optimization problem by an evolutionary process resulting in a best (fittest) solution (survivor). Lofty Zadeh, the inventor of FL, defined ES as hard or precise computing and FL, NNW and GA as soft or approximate computing [1-2]. This paper presents the speed control scheme of vector controlled induction motor drive involves decoupling of the speed and reference speed into torque and flux producing components. Fuzzy logic and artificial neural network based control scheme is simulated. The performance of fuzzy logic and artificial neural network based controllers’ is compared with that of the conventional proportional integral controller. The dynamic modeling of Induction motor is done and the performance of the Induction motor drive has been analyzed for constant and variable loads[3-4].

## II. Dynamic Simulation Of Induction Motor Drive

Dynamic behavior of induction motor can be expressed by voltage and torque which are time varying. The differential equations that belongs to dynamic analysis of induction motor are so sophisticated. Then with the change of variables, the complexity of these equations can be decreased through movement from polyphase winding to two phase winding (d-q). In other words, the stator and rotor variables like voltage, current and flux linkages of an induction machine are transferred to another reference model which remains stationary. The dynamic model of an induction motor is developed by using equations given in Appendix 'A'. The simulation model is constructed based on the equations as shown in fig. 1. The motor drive has balanced 3-phase voltages as the input, and the abc currents as the outputs. The complete simulink model of the vector controlled induction motor drive with flux controller, vector controller, PI controller and PWM inverter is shown in fig. 2.

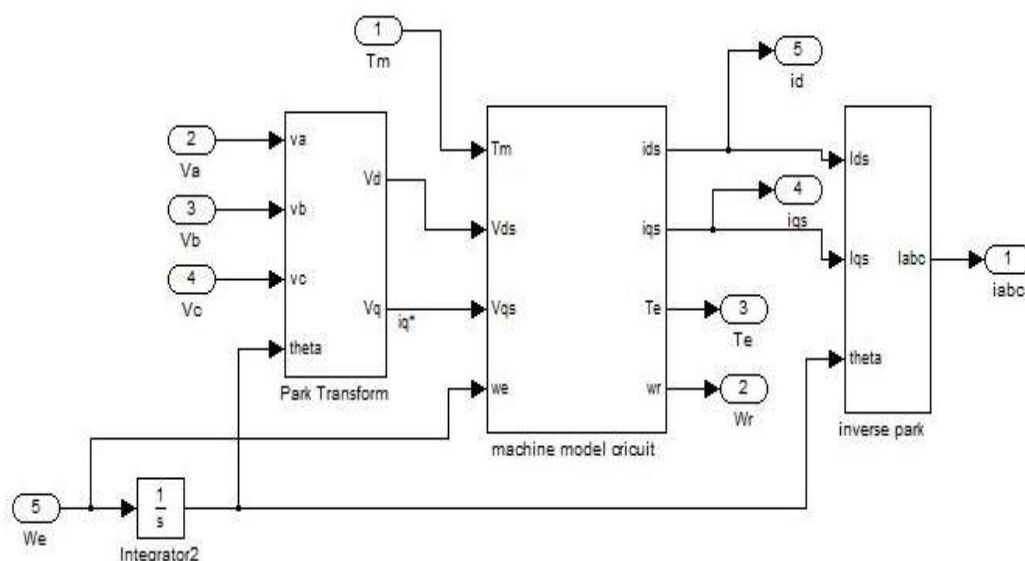

Fig. 1 Induction Motor Model

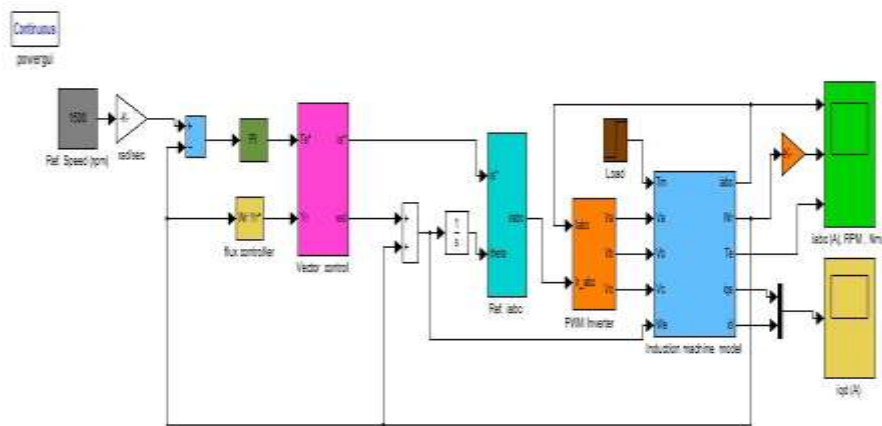

Fig. 2 Induction motor with different controllers

### III. Artificial Intelligent Controller

Despite the great efforts devoted to induction motor control, many of the theoretical results cannot be directly applied to practical systems. The difficulties that arise in induction motor control are complex computations, model nonlinearity and uncertainties in machine parameters. Recently, intelligent techniques are introduced in order to overcome these difficulties. Intelligent control methodology uses human motivated techniques and procedures (for example, forms of knowledge representation or decision making) for system control. The definition of intelligent control from Astrom and McAvoy has been used widely: *'An intelligent control system has the ability to comprehend, reason, and learn about processes, disturbances and operating conditions in order to optimize the performance of the process under consideration.'* Intelligent control techniques are generally classified as expert system control, fuzzy-logic control, neural-network control and genetic algorithm. Intelligent induction motor control thus refers to the control of an induction motor drive using artificial intelligence techniques as shown in Fig. 3. Various artificial intelligent controllers are explained as follows:

#### (a) Fuzzy Logic Controller:

Fuzzy logic is a technique to embody human-like thinking into a control system. A fuzzy controller can be designed to emulate human deductive thinking, that is, the process people use to infer conclusions from what they know. Fuzzy control has been primarily applied to the control of processes through fuzzy linguistic descriptions.

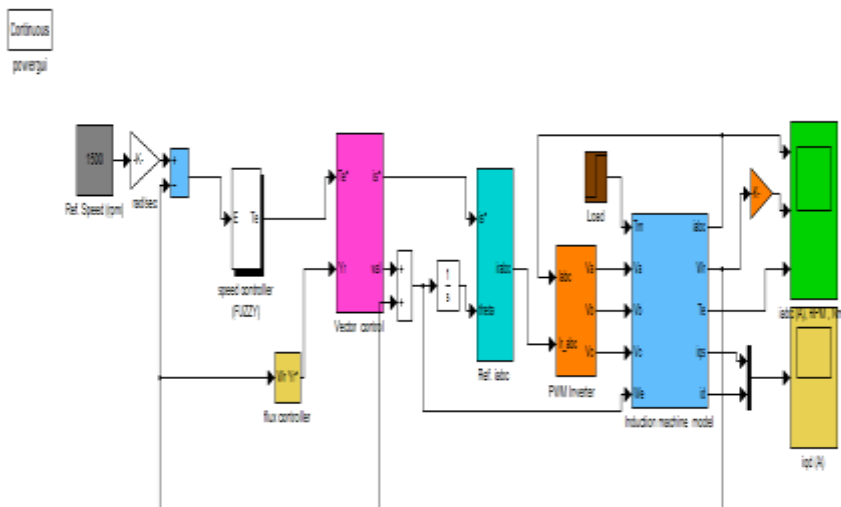

Fig. 3 Induction motor with fuzzy controller

A fuzzy controller is responsible to adjust the speed of induction motor. The operation principle of a FL controller is similar to a human operator. It performs the same actions as a human operator does by adjusting the input signal looking at only the system output. A FL based controller consists of three sections namely fuzzifier, rule base and defuzzifier. Converting crisp value to fuzzy can be done by several methods. Triangular type membership functions are used here for partitioning the crisp universes into fuzzy subsets [5-6]. The proposed Simulink induction motor with fuzzy logic is shown in Fig. 3.

TABLE-I-FUZZY RULE

E CE	NB	NM	NS	Z	PS	PM	PB
NS	NB	NB	NB	NB	NM	NS	Z
Z	NB	NB	NB	NM	NS	Z	PS
PVS	NB	NB	NM	NS	Z	PS	PM
PS	NB	NM	NS	Z	PS	PM	PB
PM	NM	NS	Z	PS	PM	PB	PB
PB	NS	Z	PS	PM	PB	PB	PB
PVB	Z	PS	PM	PB	PB	PB	PB

**(b) Artificial Neural Network (ANN):**

Artificial neural networks are nonlinear information (signal) processing devices, which are built from interconnected elementary processing devices called neurons. An Artificial Neural Network (ANN) is an information-processing paradigm that is inspired by the way biological nervous systems, such as the brain, process information does. The key element of this paradigm is the novel structure of the information processing system. It is composed of a large number of highly interconnected processing elements (neurons) working in union to solve specific problems. ANNs, like people, learn by example. An ANN is configured for a specific application, such as pattern recognition or data classification, through a learning process. Learning in biological systems involves adjustments to the synaptic connections that exist between the neurons. This is true of ANNs as well. ANN's are a type of artificial intelligence that attempts to imitate the way a human brain works. Rather than using a digital model, in which all computations manipulate zeros and ones, a neural network works by creating connections between processing elements, the computer equivalent of neurons. The organization and weights of the connections determine the output. A neural network is a massively parallel-distributed processor that has a natural propensity for storing experimental knowledge and making it available for use. It resembles the brain in two respects: Knowledge is acquired by the network through a learning process, and Inter-neuron connection strengths known as synaptic weights which are used to store the knowledge. One of the most important features of Artificial Neural Networks (ANN) is their ability to learn and improve their operation using a neural network training data[7-8]. The basic element of an ANN is the neuron which has a summer and an activation function. The mathematical model of a neuron is given by:

$$y = \varphi \left( \sum_{i=1}^N w_i * x_i + b \right) \dots\dots\dots(22)$$

where (x<sub>1</sub>, x<sub>2</sub>... x<sub>N</sub>) are the input signals of the neuron, (w<sub>1</sub>, w<sub>2</sub>,... w<sub>N</sub>) are their corresponding weights and 'b' a bias parameter. Φ is a tangent sigmoid function and y is the output signal of the neuron. The ANN can be trained by a learning algorithm which performs the adaptation of weights of the network iteratively until the error between target vectors and the output of the ANN is less than a predefined threshold. Nevertheless, it is possible that the learning algorithm did not produce any acceptable solution for all input-output association problems. The most popular supervised learning algorithm is back- propagation, which consists of a forward and backward action. In the forward step, the free parameters of the network are fixed, and the input signals are propagated throughout the network from the first layer to the last layer. In the forward phase, we compute a mean square error.

$$E(k) = \frac{1}{N} \sum_{i=1}^N (d_i(k) - y_i(k))^2 \dots\dots\dots(23)$$

where  $d_i$  is the desired response,  $y_i$  is the actual output produced by the network in response to the input  $x_i$ ,  $k$  is the iteration number and  $N$  is the number of input-output training data. The second step of the backward phase, the error signal  $E(k)$  is propagated throughout the network in the backward direction in order to perform adjustments upon the free parameters of the network in order to decrease the error  $E(k)$  in a statistical sense. The weights associated with the output layer of the network are therefore updated using the following formula:

$$w_{ji}(k+1) = w_{ji}(k) - \eta \frac{\partial E(k)}{\partial w_{ji}(k)} \dots(24)$$

where  $w_{ji}$  is the weight connecting the  $j^{\text{th}}$  neuron of the output layer to the  $i^{\text{th}}$  neuron of the previous layer,  $\eta$  is the constant learning rate. Large values of  $\eta$  may accelerate the ANN learning and consequently fast convergence but may cause oscillations in the network output, whereas low values will cause slow convergence. Therefore, the value of  $\eta$  has to be chosen carefully to avoid instability. The proposed Neural network controller is shown in Fig. 4.

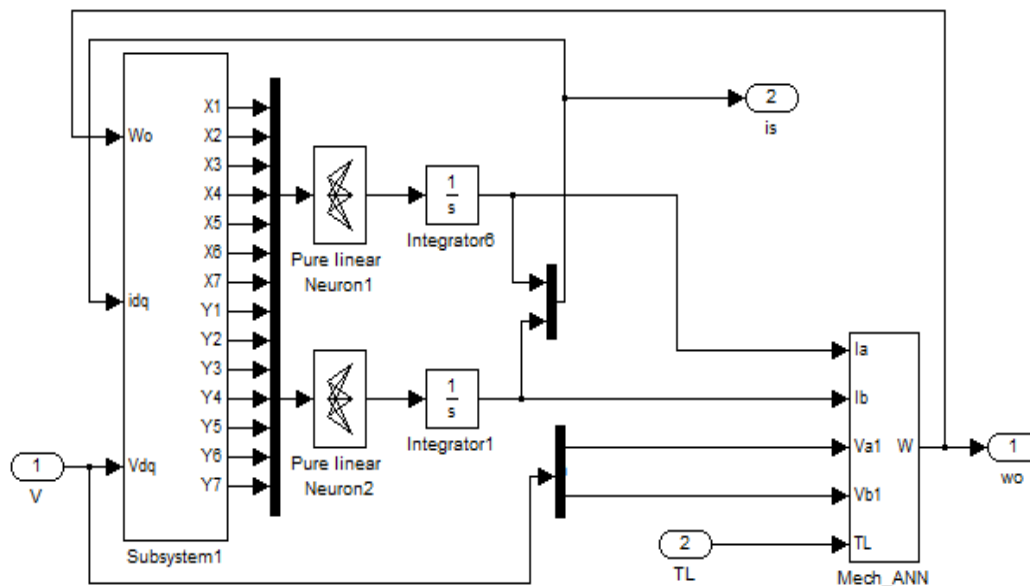

Fig. 4 Neural network controller

#### IV. Performance Assessment Of Artificial Intelligent Controller Based Induction Motor Drives

A complete simulation model for vector controlled Induction motor drive incorporating PI, Fuzzy Logic Controller and Neural network controller is developed. Vector control of Induction motor drive with Fuzzy controller is designed by proper adjustments of membership functions and Neural network controller is designed by adjusting the weights in order to get simulated results. The performance of the artificial intelligent based induction motor drive is investigated at different operating conditions. In order to prove the superiority of the Neural Network controller, a comparison is made with the response of convention PI and FLC based induction motor drive. The parameters of the induction motor considered in this study are summarized in Appendix B. The performances of the vector controlled induction motor with all intelligent controllers are presented at constant load and variable load. The dynamic behaviors of the PI controller, with FLC controller and with Neural Network controller are shown in Fig. 2, Fig.3 and Fig. 4 at constant load and variable load conditions.

**At constant load conditions:**

A drive with PI controller has a peak overshoot, but in case of fuzzy controller and neural network controller it is eliminated as shown in Fig. 5 and Fig. 6. The PI controller is tuned at rated conditions in order to make a fair comparison. Fig. 5 and Fig. 6 show the simulated starting performance of the drive with PI- and FLC-based drive systems, respectively. Although the PI controller is tuned to give an optimum response at this rated condition, the fuzzy controller yield better performances in terms of faster response time and lower starting current. It is worth mentioning here that the performance obtained by the proposed model is 13 times faster than the PI controller, i.e. it achieves the steady state 13 times faster than the PI controller. Also it is 2.1 times faster than that obtained earlier by using fuzzy controller.

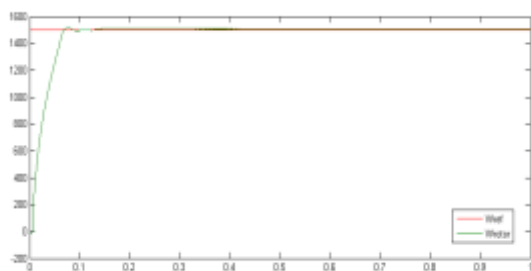

Fig. 5 (a) Rotor speed with PI controller

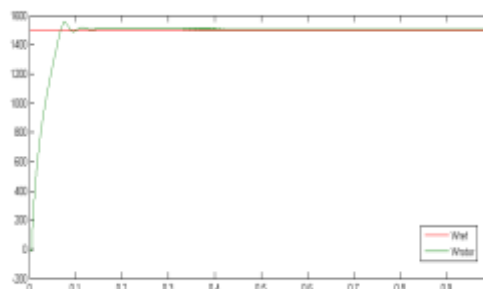

Fig. 5 (b) Rotor speed with fuzzy PI controller

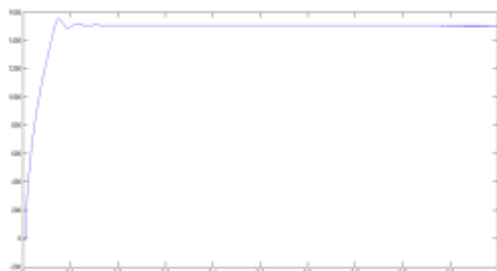

Fig.5 (c) Rotor speed with neural network controller

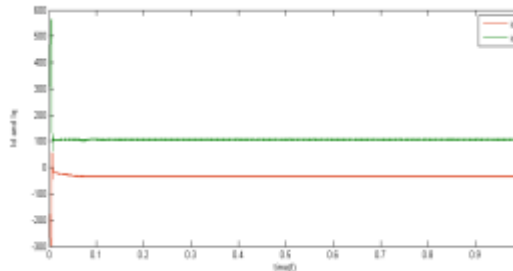

Fig.6 (a)  $I_d$  and  $I_q$  currents of Induction motor drive

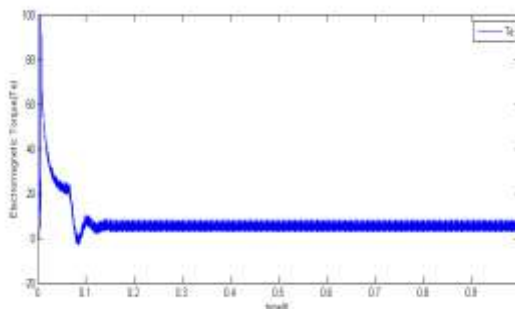

Fig 6 (b) Load torque of Induction motor drive

**At variable load conditions:**

Drive with PI controller speed response has small peak at 0.4 sec, but in case of fuzzy controller and neural network speed response is quick and smooth which shown in Fig.7. Fig.7 shows Speed, Torque,  $I_{abc}$  characteristics with PI controller. Fig.7 gives the waveform of Speed, Torque,  $I_{abc}$  characteristics with Fuzzy-logic controller. Fig.7 show the speed responses for step change in the load torque using the PI and fuzzy controller, respectively. The motor starts from standstill at load torque = 2 Nms and at  $t=0.4s$ , a sudden full load of 15 Nms is applied to the system, then it is controlled by fuzzy controller. Since the time taken by the PI controlled system to achieve steady state is much higher than fuzzy controlled system, the step change in load torque is applied at  $t = 1.25$  sec. The motor speed follows its reference with zero steady-state error and a fast response using a fuzzy controller. On the other hand, the PI controller shows steady-state error with a high starting current. It is to be noted that the speed response is affected by the load conditions. This is the drawback of a PI controller with varying operating conditions. It is to be noted that the fuzzy controller gives better responses in terms of overshoot, steady-state error and fast response. These figures also show that the

FLC-based drive system can handle the sudden increase in command speed quickly without overshoot, under-shoot, and steady-state error, whereas the PI-controller-based drive system has steady-state error and the response is not as fast as compared to the FLC. Thus, the proposed FLC-based drive has been found superior to the conventional PI-controller-based system.

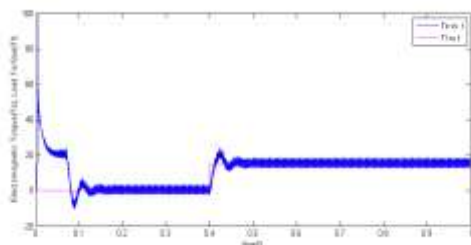

Fig.7(a) Torque characteristics with PI controller

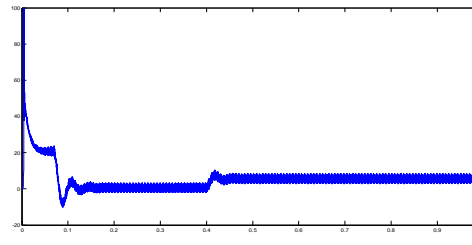

Fig.7(b) Torque characteristics with Fuzzy PI

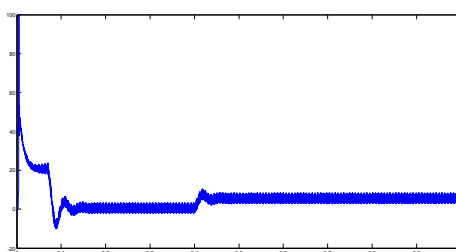

Fig.7 (c) Torque characteristics with Neural network controller

Table II and III present the performance comparison during steady state operation, transient operation and in time domain analysis respectively.

TABLE II

Performance Comparison between PI, Fuzzy, and Neural controllers during steady state operation.

Control strategies	Rise Time(s)	Time for speed regulation (s)
Conventional PI	0.24	0.25
FLC	0.2	0.07
ANN	0.08	0.04

TABLE III

Performance Comparison between PI, Fuzzy, and Neural controllers during Transient Operation

Control strategies	Settling Time before changing the load (s)	Settling Time after Changing the load(s)	Overshoot
Conventional PI	0.58	0.2	Yes
FLC	0.2	0.2	No
ANN	0.09	0.02	No

## V. Conclusion

An Artificial intelligent based vector controlled induction motor has been presented in this paper. The vector control strategy is developed with Fuzzy logic controller and Neural network controller. The conventional vector control of induction motor is compared with the proposed artificial intelligence based

controllers, and their performance with fuzzy and neural network controllers is better than PI controller. The comparative results prove that the performance of vector-control drive with fuzzy controller is superior to that with conventional PI controller. Thus, by using fuzzy controller the transient response of induction machine has been improved greatly and the dynamic response of the same has been made faster. The robustness in response is evident from the results. Since exact system parameters are not required in the implementation of the proposed controller, the performance of the drive system is robust, stable, and insensitive to parameters and operating condition variations. The performance has been investigated at different dynamic operating conditions. It is concluded that the proposed FLC has shown superior performances over the PI controller and has its transient response 13 times faster than a simple P-I controlled system and also 2.1 times faster than earlier proposed system. Some of the advantages of Neural Controller are reduced number of rules, faster speed of operation and no need for modifications in membership function by conventional trial and error method for optimal response. This makes Neural Controller a easy-build and robust controller. The performances of the proposed Neural Controller based drive have been investigated at various operating conditions. A performance comparison between PI based drive, FLC based drive and the proposed Neural Controller based drive has been presented. The proposed Neural Controller based IM drive has been found to be robust for high performance drive application.

**VI. Appendix A Dynamic Model Of Induction Motor**

The following equations are used for dynamic modeling of induction motor

$$v_{abc} = v_a + v_b e^{-j2\pi/3} + v_c e^{+j2\pi/3} \dots\dots\dots(1)$$

$$\frac{2}{3} v_{abc} e^{-j\theta} = v_{qs} - jv_{ds} \dots\dots\dots(2)$$

$$v_{ds} = r_s i_{ds} + \frac{d}{dt} [L_{ls} i_{ds} + L_m i'_{dr}] + L_m \frac{d}{dt} i_{ds} - \omega \phi_{qs} \dots\dots\dots(3)$$

$$\phi_{ds} = L_s i_{ds} + L_m i'_{dr} \dots\dots\dots(4)$$

$$\phi'_{dr} = L_m i_{ds} + L_r i'_{dr} \dots\dots\dots(5)$$

$$L_s = L_{ls} + L_m \dots\dots\dots(5a)$$

$$v_{ds} = r_s i_{ds} + \frac{d}{dt} \phi_{ds} - \omega \phi_{qs} \dots\dots\dots(6)$$

$$\phi_{ds} = \int (v_{ds} - r_s i_{ds} + \omega \phi_{qs}) \dots\dots\dots(7)$$

$$v'_{dr} = r'_r i'_{dr} + \frac{d}{dt} \phi'_{dr} - (\omega - \omega_r) \phi'_{qr} \dots\dots\dots(8)$$

$$\phi'_{dr} = \int [v'_{dr} - r'_r i'_{dr} + (\omega - \omega_r) \phi'_{qr}] \dots\dots\dots(9)$$

$$v_{qs} = r_s i_{qs} + \frac{d}{dt} [L_{ls} i_{qs} + L_m i'_{qr}] + \omega [L_{ls} i_{ds} + L_m i'_{dr}] \dots\dots\dots(10)$$

$$\phi_{qs} = L_s i_{qs} + L_m i'_{qr} \dots\dots\dots(11)$$

$$\phi'_{qr} = L_m i_{qs} + L_r i'_{qr} \dots\dots\dots(12)$$

$$v_{qs} = r_s i_{qs} + \frac{d}{dt} \phi_{qs} + \omega \phi_{ds} \dots\dots\dots(13)$$

$$\phi_{qs} = \int (v_{qs} - r_s i_{qs} - \omega \phi_{ds}) \dots\dots\dots(14)$$

$$v'_{qr} = r'_r i'_{qr} + \frac{d}{dt} \phi'_{qr} + (\omega - \omega_r) \phi'_{dr} \dots\dots\dots(15)$$

$$\phi'_{qr} = \int [v'_{qr} - r'_r i'_{qr} - (\omega - \omega_r) \phi'_{dr}] \dots\dots\dots(16)$$

$$\begin{bmatrix} \phi_{ds} \\ \phi_{qs} \\ \phi'_{dr} \\ \phi'_{qr} \end{bmatrix} = \begin{bmatrix} L_s & 0 & L_m & 0 \\ 0 & L_s & 0 & L_m \\ L_m & 0 & L_r & 0 \\ 0 & L_m & 0 & L_r \end{bmatrix} \begin{bmatrix} i_{ds} \\ i_{qs} \\ i'_{dr} \\ i'_{qr} \end{bmatrix} \dots\dots\dots(17)$$

$$T_e = \frac{3}{2} \frac{P}{2} [\phi'_{dr} i_{qs} - \phi'_{qr} i_{ds}] \dots\dots\dots(18)$$



$$w_r = \frac{1}{Js+B} \cdot T_e \quad \dots\dots\dots(19)$$

$$\theta_r = \int w_r \quad \dots\dots\dots(20)$$

$$T_e = \frac{3}{2} \frac{P}{2} [\phi'_{dr} i_{qs}] \quad \dots\dots\dots(21)$$

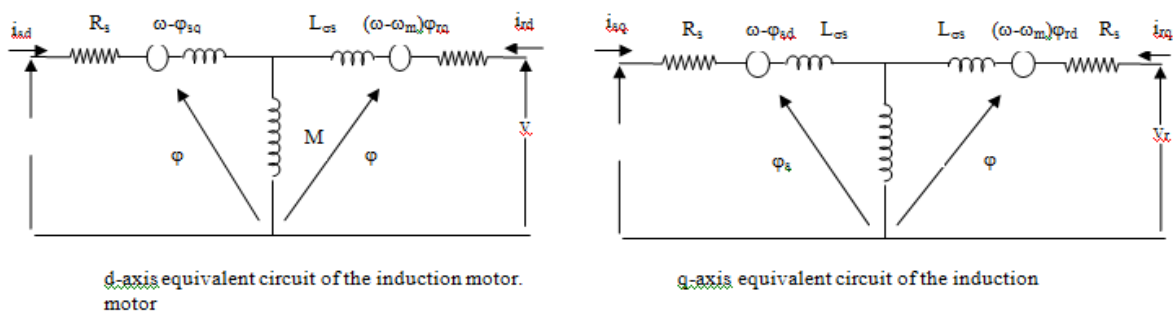

### VII. Appendix B

The parameters of the induction motor are as follows:

p = 4            R<sub>s</sub> = 2.2 Ohm            R<sub>r</sub> = 0.9 Ohm    L<sub>cs</sub> = 10            L<sub>r</sub> = 2.0            L<sub>m</sub> = 69.3  
 f = 50Hz        J = 0.031kg m<sup>2</sup>            B = 0.012    V<sub>dc</sub> = 200V    Proportional gain = 2.0    Integral gain = 0.1240

### References

- [1] K. L . Shi, T . F. Chan, Y. K. Wong and S. L . HO, Modeling and simulation of the three phase induction motor Using SIMULINK, Int.J. Elect. Enging. Educ., Vol. 36, 1999, pp. 163–172.
- [2] Tze Fun Chan and Keli Shi, Applied intelligent control of induction motor drives, (IEEE Willey Press, First edition, 2011).
- [3] P.C. Krause, Analysis of Electrical Machinery and Drives System, (IEEE Willey Press, 2002).
- [4] Ned Mohan, Advanced Electric Drives: Analysis, Control Modeling using Simulink,(MNPERE Publication ,2001).
- [5] M. Nasir Uddin and Muhammad Hafeez, FLC-Based DTC Scheme to Improve the Dynamic Performance of an IM Drive, IEEE Trans.on Industry Applications , Vol -48 , No 2, Mar/Apr 2012, pp 823-831.
- [6] M. Nasir Uddin and Muhammad Hafeez.FLC-Based DTC Scheme to Improve the Dynamic Performance of an IM Drive,” IEEE Trans. on Industry Applications , Vol -48 , No 2, Mar/Apr 2012; 823-831.
- [7] M. Nasir Uddin, Hao Wen . Development of a Self-Tuned Neuro-Fuzzy Controller for Induction Motor Drives. IEEE Trans on industry application. vol. 43, no. 4, July/august 2007,pp 1108-1116.
- [8] M Nasir Uddin, Tawfik S. Radwan and Azizur Rahman, Performance of Fuzzy logic based indirect vector control for induction motor drive. IEEE Trans on industry application, volume 38, no.5 Sept /Oct 2002, pp 1219-1225.
- [9] Besir Dandil ,Muammer Gokbulut Fikrat Ata, A PI Type Fuzzy –Neural Controller for Induction Motor Drives, Journal of Applied Sciences 5(7) 2005, pp 1286-1291.
- [10] Pradeep Chatterjee, B.M. Karan and P.K. Sinha, Fuzzy Control of Induction Motor with Reduced Rule Base, Serbian Journal of Electrical Engineering, Vol-4, No-2,Nov 2007, pp 147-159.
- [11] I.H. Altas and A.M. Sharaf, A Generalized Direct Approach for Designing Fuzzy Logic Controllers in Matlab/Simulink GUI Environment, International Journal of Information Technology and Intelligent Computing, Int. J. IT&IC no.4 vol.1, 2007.
- [12] Rajesh Kumar, R. A. Gupta and Rajesh S. Surjuse, Adaptive Neuro-Fuzzy Speed Controller for Vector Controlled Induction Motor Drive, Asian Power Electronics Journal, Vol. 3, No. 1, Sept 2009, pp 8-14.
- [13] Mouloud Azzedine Denai and Sid Ahmed Attia, “Fuzzy and Neural Control of an Induction Motor,” Int. J. Appl. Math. Computer. Sci., 2002, Vol.12, No.2, pp 221–233.
- [14] R. Arulmozhiyal and K. Baskaran, Implementation of a Fuzzy PI Controller for Speed Control of Induction Motors Using FPGA, Journal of Power Electronics, Vol. 10, No. 1, January 2010, pp 65-71
- [15] B.Subudhi1, Anish Kumar A.K and D. Jena,dSPACE implementation of Fuzzy Logic based Vector Control of Induction Motor, TENCON 2008 IEEE Conference19-21Nov.2008, pp1-6.
- [16] Bimal K. Bose,Neural Network Applications in Power Electronics and Motor Drives -An Introduction and Perspective, IEEE Trans. on Industrial Electronics, Vol. 54, No. 1, February 2007, pp- 14-33.
- [17] K. Mohanasundaram, Dr. K. Sathiyasekar, Dr. N. Rajasekar,Neuro-fuzzy Controller for High Performance Induction Motor Drives, International Journal of Computer Applications,Vol 38– No.10, January 2012.
- [18] P M Menghal & A Jaya Laxmi “Real Time Control of Electrical Machine Drives: A Review” IEEE International Conference on Power Electronics, Control and Embedded Systems (ICPES) Nov 29 - Dec 1 2010, MNNIT, Allahabad, India, pp 1-6.
- [19] P M Menghal & A Jaya Laxmi “Real Time Simulation: A Novel Approach in Engineering Education” IEEE 3rd International Conference on Electronics Computer Technology (ICECT 2011), Kanyakumari, India on 8 -10 April 2011, pp V1-215- V1-219.
- [20] P M Menghal & A Jaya Laxmi “Real Time Simulation: Recent Progress & Perspective” International Journal of Electrical Engineering and Electrical Systems (IJEEES), July 2010 – September 2010 Volume 03, Issue No 01, pp 45-59.
- [21] P M Menghal & A Jaya Laxmi “Real Time Control of Electrical Machine and Drives : A Review” International Journal of Advances in Engineering & Technology (IAET), Vol. 1, Issue 4, Sept 2011, pp. 112-126.
- [22] P M Menghal & A Jaya Laxmi “Real Time Simulation: Recent Progress & Challenges” IEEE 2nd International conference on Power, Signals, Control & Computation (EPSCICON 2012), Vidya Academy Of Science & Technology, Thrissur, India on 3-6 Jan 2011.
- [23] P M Menghal & A Jaya Laxmi “State of the Art of Intelligent Control of Induction Motor Drives” Michael Faraday IET India Summit – 2012 Kolkata 25 Nov 2012, pp 47-52.