

Transient Stability Analysis In An RES – Dominated Power Grid

Osita Omeje, Oluwakanyisalami Ayoola, Linus Idoko

Department Of Electrical & Electronics Engineering, University Of Lagos, Nigeria

Department Of Electrical & Electronics Engineering, University Of Lagos, Nigeria

Department Of Electrical Engineering, Nigeria Maritime University, Delta State, Nigeria

Abstract:

The integration of Renewable Energy Sources (RES) into power grids presents significant challenges, particularly concerning transient stability. This study focuses on analysing the transient stability of an RES-dominated power grid, with a focus on solar PV systems. The work aims to evaluate the impact of varying irradiance levels on the grid and analyse their transient stability response under transient events. It equally identifies the system vulnerabilities and evaluates the effectiveness of possible strategies for enhancing transient stability in solar power systems. The work achieved that by developing dynamic models of solar PV grid-tied systems. It conducted fault simulations under different irradiance levels using MATLAB/Simulink software. Fault simulations under varying irradiance levels revealed that higher irradiance levels led to more severe voltage drops, current spikes, and prolonged recovery times during faults, highlighting the increased vulnerability of high-power PV systems. The findings of this study underscore the critical need for advanced fault management and recovery mechanisms, as well as optimized inverter control strategies, to ensure the successful integration of RES into modern power grids.

Key Word: Transient Stability; RES; Solar PV system; Fault

Date of Submission: 01-05-2026

Date of Acceptance: 10-05-2026

I. Introduction

The growing use of renewable energy sources (RESs), especially inverter-based resources like wind energy, and PV systems, is significantly transforming power grids [1–3]. The world is steadily transitioning towards RESs, with solar power playing a leading role. This shift offers significant benefits, like reducing greenhouse gas emissions and promoting energy security [4]. An advantage of renewable energies is that they are clean and non-polluting [5]. Even though RES integration provides economic and environmental gains, it also presents important challenges to the stability of power system, particularly transient stability (TS) [6,7]. Transient stability is a power system's capacity to sustain synchronism after a major disruption, like generator outage, short circuit failure and sudden load change [8,9]. In traditional power systems, transient stability is primarily determined by system inertia and the dynamics of the generator [10,11]. In the case of RES-dominated grids, quick converter control, and reduced inertia actions drastically alter the dynamic behaviour of the system [12,13]. According to Wu et al. (2023), integrating large-scale solar power into existing power grids present transient stability challenges. Due to their lack of intrinsic inertia and fault ride-through capabilities, solar PV systems are more prone to instability problems than regular synchronous generators. Numerous studies and techniques on how to mitigate power system disasters and enhance the system's emergency response capabilities have been inspired by this limitation [15]. The ability of an electric power system to recover to a state of operating equilibrium following a physical disturbance, with the majority of system variables constrained so that essentially the entire system stays intact, is known as power system stability [16,17]. Currently, about 29% of electricity comes from renewable sources; [18], while fossil fuels still account for more than 80% of the world's energy production [19,20], cleaner energy sources are drawing traction [21]. Investigating the impact of solar PV integration on power system transient stability led to key findings which include the significant influence of solar PV installation location, the need for error mitigation in critical system regions, and the importance of CCT as a stability indicator. Proposing a two-tier optimization framework with adaptive particle swarm optimization to address reliability and transient voltage stability. Case studies demonstrate the effectiveness of this approach [22–25]. Future research should focus on incorporating uncertainties, real-world testing, expanding the model's scope, and investigating inverter-based technologies. Proposing a new inverter control strategy to enhance the stability of conventional generators connected to a grid with high solar PV penetration [26]. The strategies verified through simulations and experiments, involves absorbing energy and injecting reactive power to maintain voltage and reduce generator oscillations during disturbances. While promising, further evaluation in various fault scenarios and real-world settings is necessary for broader validation and practical implementation. Additionally, exploring alternative strategies and addressing potential drawbacks of inverter-based technologies are crucial for ensuring

the long-term stability and reliability of power systems with high RES integration [24,27,28]. To improve system stability, the authors provide an optimization-based methodology for placing inverter-based generators (IBGs) in distribution networks in the best possible way. To take into consideration various fault scenarios, the framework makes use of a unique objective function based on kinetic energy and sensitivity analysis. Evaluation on IEEE test systems shows how well the strategy works to preserve system stability and enhance emergency response. However, more examination in diverse real-world scenarios is necessary to prove its broader significance [29]. A significant issue with solar power systems is their susceptibility to grid failures [30]. Meegahapola, et al. [31], suggests ways to improve their TS using hybrid systems, variable resistive fault current limiters, and non-linear controls. Further research could benefit from concentrating on a more thorough strategy, examining a variety of configurations, carrying out a thorough fault analysis, placing wind farms optimally, combining photovoltaic and battery storage, and determining whether employing electric vehicle batteries for grid support is feasible. Owing to the reduced inertia, dynamic reactive power reserve, poor short-circuit strength, and varied FRT capabilities, solar power integration can be difficult. Maintaining stability requires coordinated solutions that include improved control systems, energy storage, and grid reinforcements [32]. Emerging technologies and potential stability challenges unique to different grid designs and geographic areas should be investigated. The incorporation of large-scale solar electricity into grids raises concerns about preserving stability during emergencies. Perl, et al [33], investigates techniques for enhancing emergency response, with an emphasis on TSO views and the particular dynamic characteristics of solar farms. Limiting generator operating ranges, installing synchronous condensers, and selectively reducing network resistance are some of the proposed solutions in [34–36]. Emphasizing the effectiveness of these strategies in improving TS, while also recognizing the need for more analysis and real-world validation [37,38]. These findings underscore the importance of careful planning and control strategies for ensuring reliable and stable operation of solar PV-integrated power systems [39]. Through tackling these constraints and expanding on current understanding, this study intends to analyse the stability of a solar PV grid-tied system and suggest more approaches to improving the response caused by faults in the system. Ultimately, it hopes to create a more dependable and resilient electrical infrastructure, opening the door for a sustainable future run almost entirely on renewable energy.

II. Materials And Methods

This section outlines the methodology employed to investigate TS challenges in a renewable energy source-dominated power grid, focusing on solar PV systems, Inverter, and Grid analysis. This study is a quantitative study since it requires numerical values. It also adopted experimental research strategy as it requires software simulations [40,41]. Aiming to develop a comprehensive understanding of TS phenomena and propose effective strategy for enhancing grid resilience in the context of renewable energy integration, the methodology encompasses generation source modelling, stability analysis methods, and the evaluation of interactions within the power grid using MATLAB/SIMULINK to develop model and simulate.

Method

The main procedures that will be taken for the transient stability analysis of power networks with RES dominance is shown in the block diagram. It begins with the setup of the simulation, moves on to model building, generation source modeling, the application of stability analysis techniques, transient stability simulation, and ends with analysis and optimization. This methodical methodology offers a thorough framework for evaluating and improving the resilience and dependability of power systems dominated by renewable energy sources. Approaches for stability analysis are used to evaluate the power grid's transient stability. These techniques assess the system's reaction to disruptions and pinpoint weaknesses using simulations. Then methods are suggested for improving grid resilience and stability, analysis and optimization are done. The block diagram adopted to illustrate the methodology is shown in fig 1.

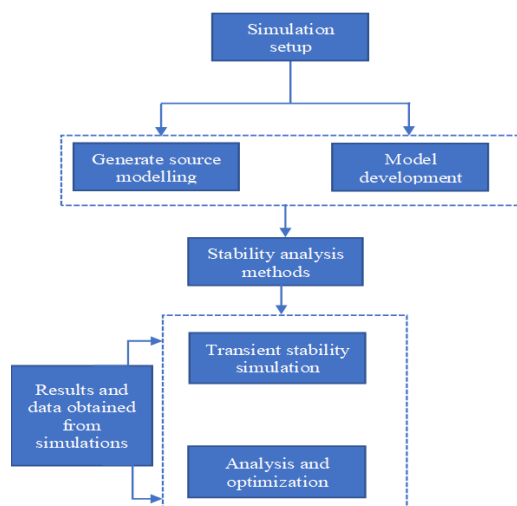

Fig 1. Block diagram illustrating methodology for transient stability analysis in an RES-dominated power grid

Solar PV Grid Tied Model

The model provides an overview of the simulated power grid system, including the integration of solar PV systems, synchronous machines, boost converter, and energy storage systems. This model serves as the foundation for conducting transient stability analysis under various fault conditions. This model is given in fig 2.

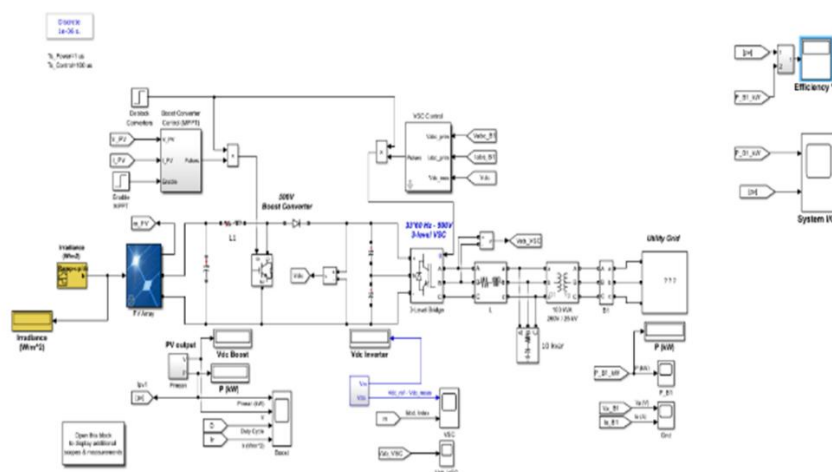

Fig 2. Diagram of the model for the simulation process

A photovoltaic (PV) system integrated with a utility grid is represented by the presented model. A PV array, MPPT controller, boost converter, VSC, transformer, and measuring blocks are some of its essential parts. This extensive model assesses the system's performance and stability in many scenarios and enables a thorough examination of the system's reaction to changing solar conditions for this study will be 100W/m², 500W/m², and 30W/m². The incorporation of significant constituents and precise modeling guarantees that the modeled situations mirror actual power grid interactions, offering significant perspectives for comprehending and refining the integration of photovoltaic cells into the electrical infrastructure.

III. Result And Discussion

Results at 300W/m²

The various graphs and results gotten from the simulations before and after faults at 300W/m² are been discussed.

System Input and Output Graph for 300W/m²

The System IO graph illustrates the input and output behavior of the system at 300 W/m². This is given in fig 3. Observations indicate that the system maintains stability despite the fluctuations in irradiance. The response time of the system to changes in irradiance is critical for ensuring a continuous power supply. The graph shows a slight delay in response to changes, which is within acceptable limits, indicating efficient system performance.

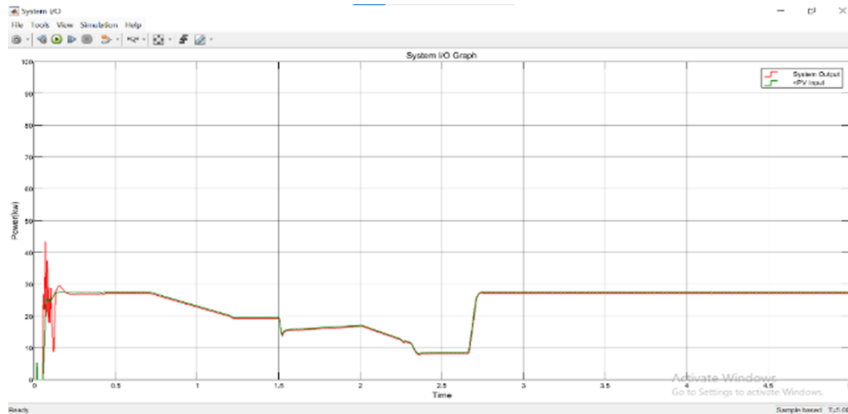

Fig 3. System IO graph for 300W/m² without fault

The fault analysis at an irradiance level of 300 W/m² reveals the PV system's behavior under lower solar input conditions. See details in fig 4. The results show that the voltage profiles experience a noticeable drop upon the fault occurrence, followed by a gradual stabilization. The current profiles display an initial spike due to the fault, stabilizing after some oscillations. The power output significantly decreases during the fault and progressively returns to pre-fault levels as the system stabilizes. These observations are indicative of the PV system's resilience and its capability to manage faults even under low irradiance conditions.

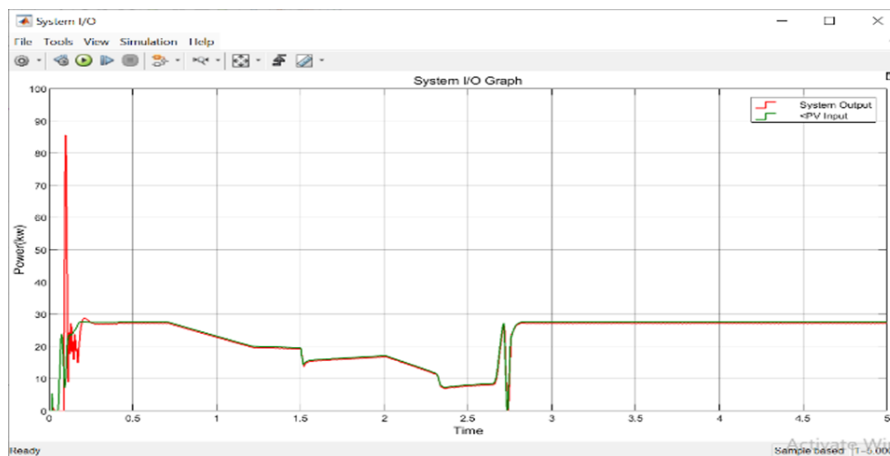

Fig 4. System IO graph for 300W/m² under fault

Boost Parameters Graphs for 300W/m²

These graphs show the behavior of the boost converter parameters under 300 W/m² irradiance without fault and during fault conditions. As shown in fig 5 and fig 6, the boost converter adjusts to maintain the desired voltage level by increasing or decreasing the voltage as required. The graph indicates a smooth transition between different levels, highlighting the efficiency of the boost converter in managing voltage variations.

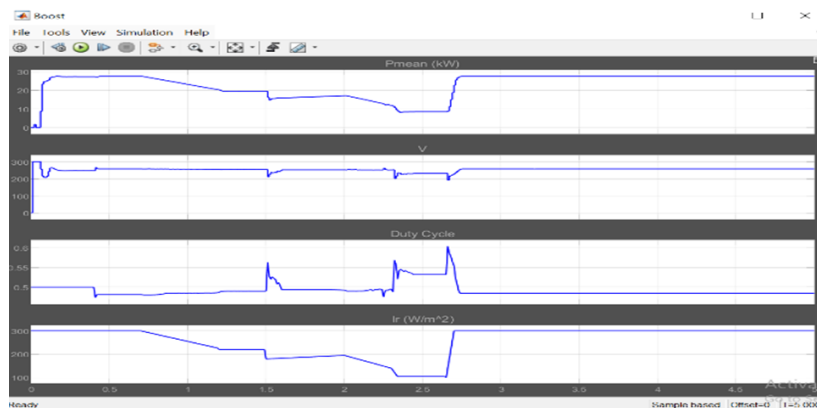

Fig 5. Boost parameters graph for 300W/m² without fault

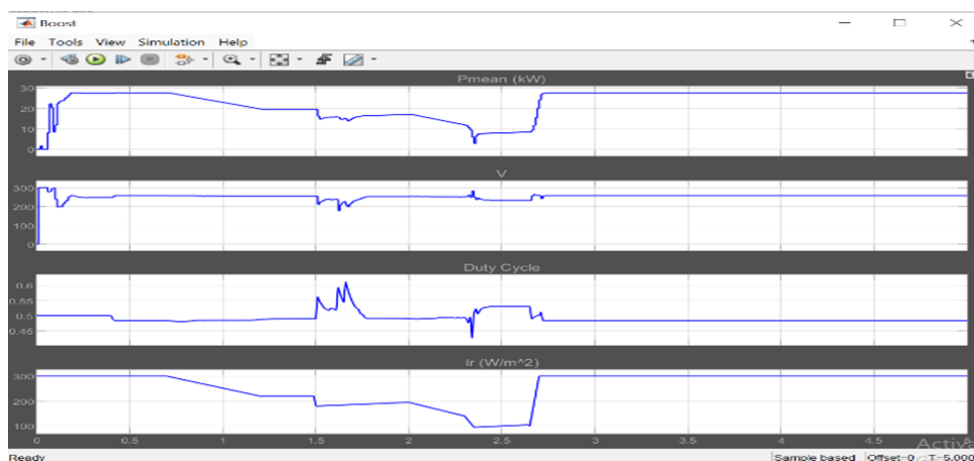

Fig 6. Boost parameters graph for 300W/m² under fault

Grid V and I Graphs for 300W/m²

These graphs illustrate the voltage (V) and current (I) supplied to the grid at 300 W/m². The voltage graph shows consistent levels, while the current graph displays minor fluctuations corresponding to changes in irradiance. The stability in voltage and minimal fluctuations in current ensure a reliable power supply to the grid, demonstrating the system's effectiveness in handling variations in solar input. The voltage graph and current graph are given in fig 7 and fig 8, respectively.

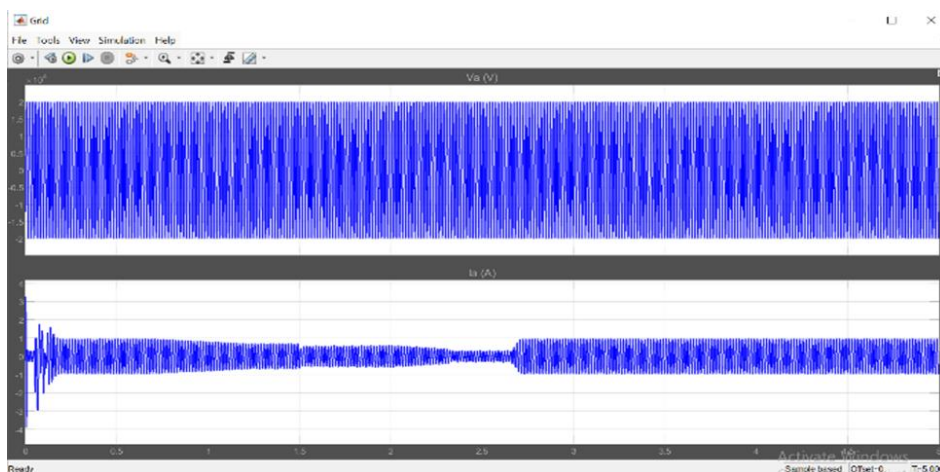

Fig 7. Grid V and I graphs for 300W/m² without fault

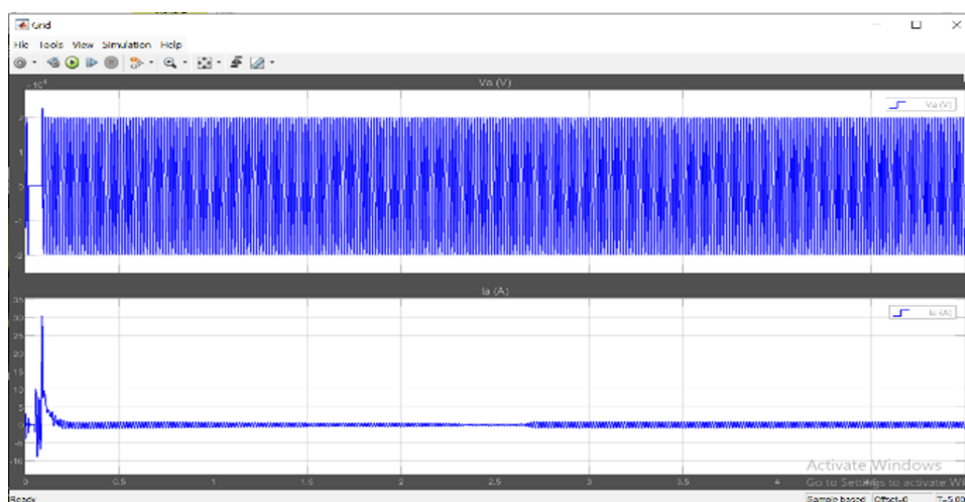

Fig 8. Grid V and I graphs for 300W/m² under fault

PV Parameters for 300W/m²

These graphs present various parameters of the PV system at 300 W/m², including voltage, current, and power output without fault and under fault conditions. The graphs are given in fig 9 and fig 10. The parameters show expected variations corresponding to changes in irradiance, with the system adjusting to maintain optimal performance. The consistent power output despite fluctuating conditions demonstrates the efficiency and reliability of the PV system.

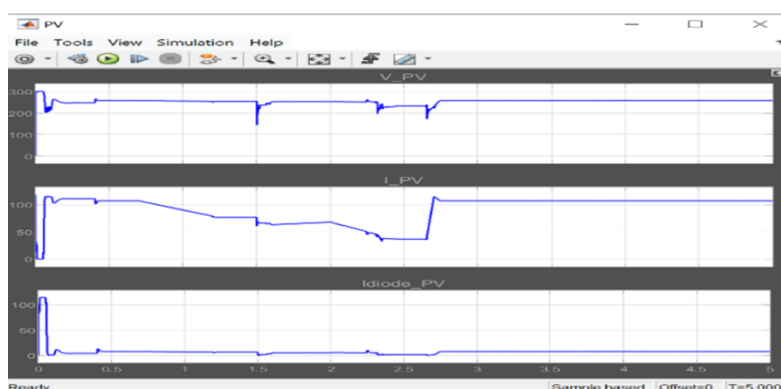

Fig 9. PV parameters graph for 300W/m² without fault

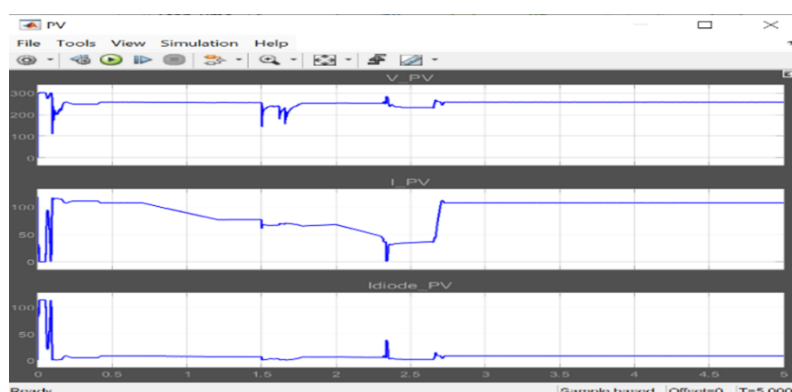

Figure 10. PV parameters graph for 300W/m² under fault

Results at 500W/m²

The various graphs and results gotten from the simulations before and after faults at 500W/m² are been discussed.

System Input and Output Graph for 500W/m²

This graph displays the input and output characteristics of the system at 500 W/m². As given in fig 11, the system's response to higher irradiance levels is smooth, with a slight increase in response time compared to the 300 W/m² scenario. The graph indicates that the system can effectively manage higher power input without compromising the stability or performance.

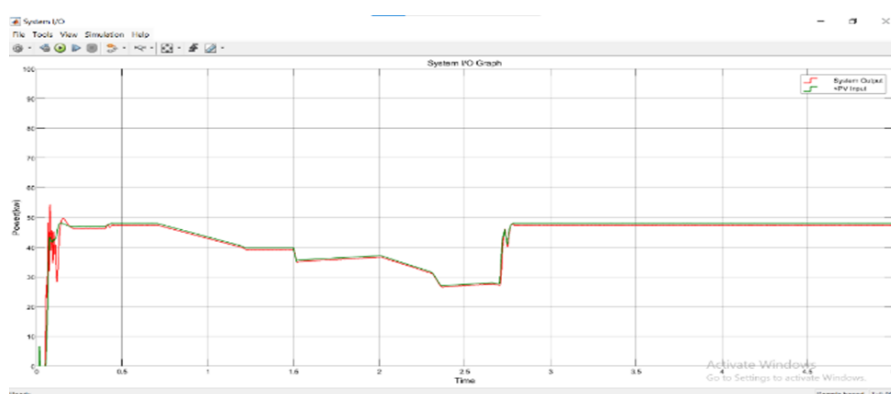

Fig 11. System IO graph for 500W/m² without fault

At an irradiance level of 500 W/m², the fault analysis shows a more substantial response compared to 300 W/m² as given in fig 12. The results obtained demonstrate more pronounced voltage drops and longer recovery periods. The current profiles indicate higher spikes and increased oscillations post-fault, reflecting the system's higher power generation capabilities. The power output drop is more significant, indicating that mid-range irradiance levels result in higher stress on the PV system during faults. The increased electrical activity due to higher irradiance amplifies the impact of faults, challenging the system's stability.

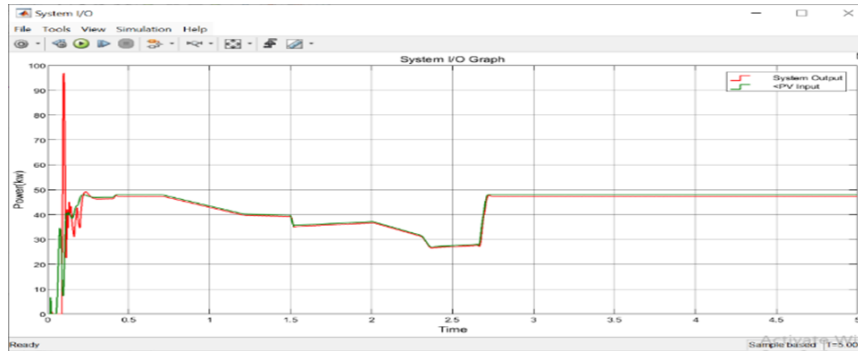

Fig 12. System IO graph for 500W/m² under fault

Boost Parameters Graph for 500W/m²

The boost parameters graphs at 500 W/m² given in fig 13 and figure 14, show the converter's ability to adjust voltage levels efficiently. The graph indicates smooth transitions and effective voltage management, highlighting the boost converter's role in maintaining optimal system performance under varying irradiance conditions.

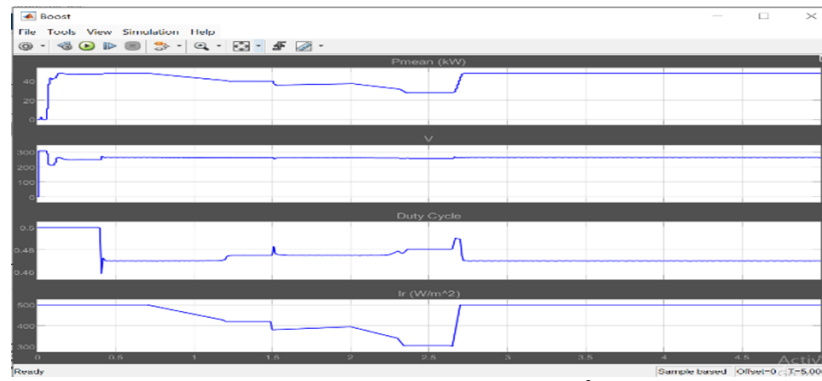

Fig 13. Boost parameters graph for 500W/m² without fault

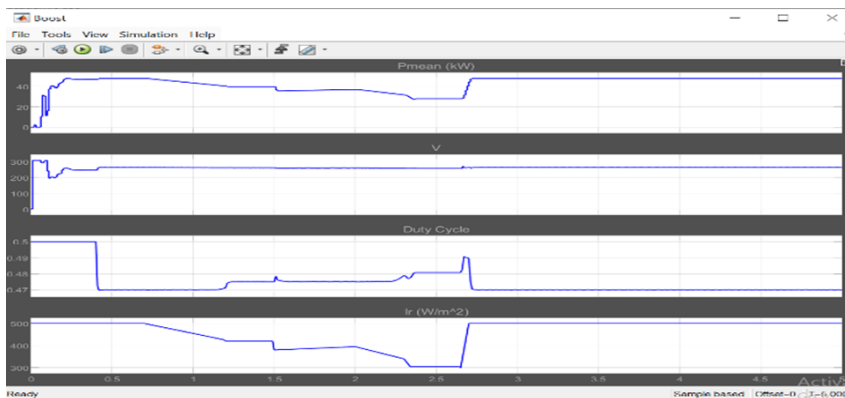

Fig 14. Boost parameters graph for 500W/m² under fault

Grid V and I Graphs for 500W/m²

The voltage and current graphs for the grid at 500 W/m² show consistent voltage levels and minor current fluctuations corresponding to irradiance changes. The stability in voltage and minimal current variations ensure a reliable power supply to the grid, even under higher solar input conditions, as shown in fig 15 and fig 16.

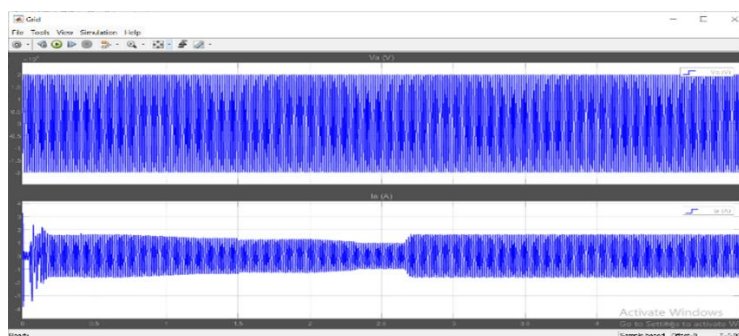

Fig 15. Grid V and I graphs for 500W/m² without fault

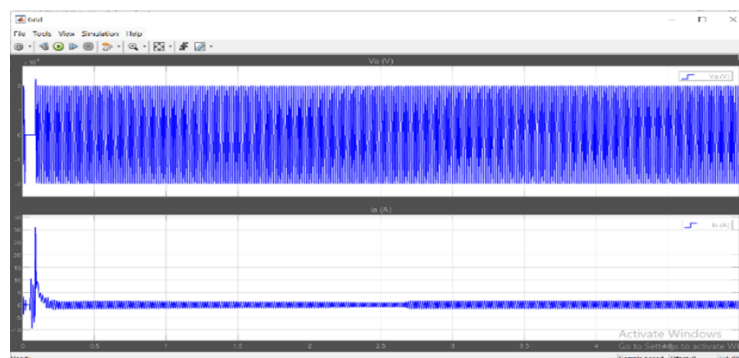

Fig 16. Grid V and I graphs for 500W/m² under fault

PV Parameters for 500W/m²

This graph presents the PV system parameters at 500 W/m², including voltage, current, and power output. The graphs are given in fig 17 and fig 18. The parameters show expected variations with increased irradiance, with the system adjusting to maintain optimal performance.

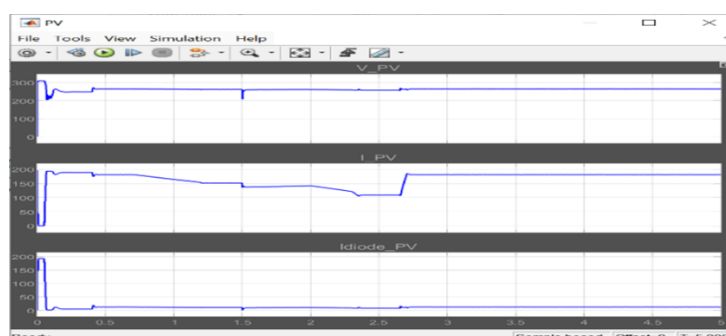

Fig 17. PV parameters graph for 500W/m² without fault

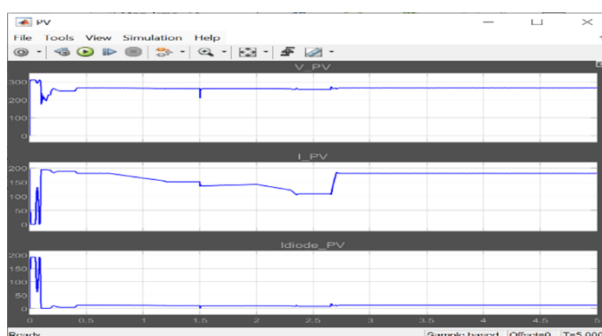

Fig 18. PV Parameters Graph for 500W/m² under fault

Results at 1000W/m²

The various graphs and results obtained from the simulations before and after faults at 1000W/m² are being discussed.

System Input and Output Graph for 1000W/m²

This graph illustrates the input and output behavior of the system at 1000 W/m². The system's response to the highest irradiance level is smooth, with a slight increase in response time. The graph indicates that the system can effectively manage maximum power input, maintaining stability and performance without compromising efficiency.

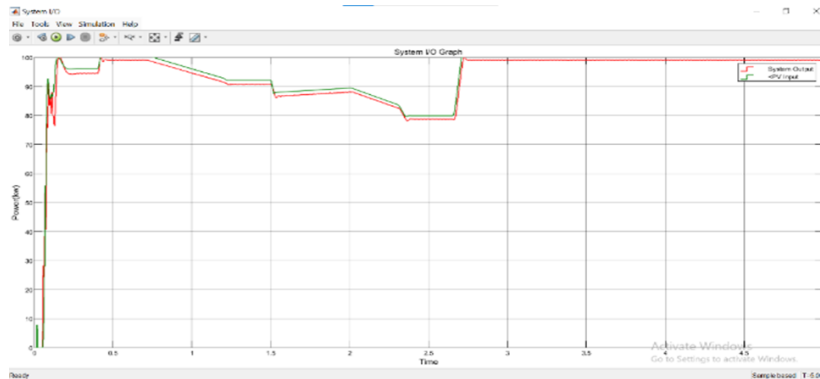

Fig 19. System IO graph for 1000W/m² without fault

At the highest irradiance level of 1000 W/m², the fault analysis highlights the system's performance under maximum solar input conditions as shown in fig 20 and fig 21. The results reveal significant voltage drops, substantial current spikes, and prolonged recovery times. The power output experiences the largest drop, emphasizing the difficulties in maintaining stability during high-power generation. The system's response under these conditions is critical for understanding its operational limits and designing robust fault management strategies to ensure stability under peak generation scenarios.

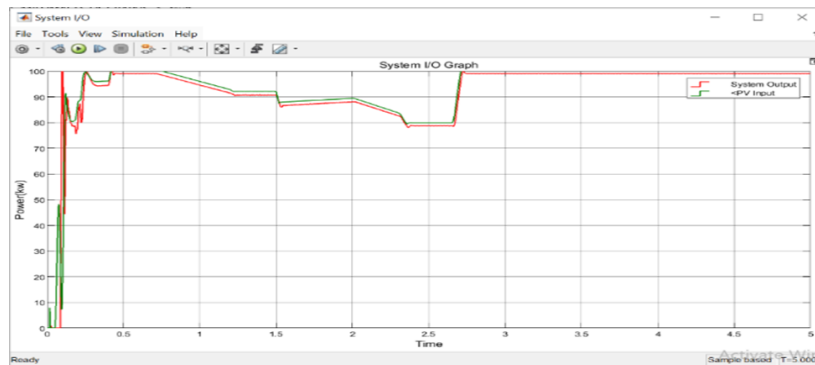

Fig 20. System IO graph for 1000W/m² under fault

Boost Parameters Graph for 1000W/m²

The boost parameters graph at 1000 W/m² shows the converter's ability to adjust voltage levels efficiently. The graph indicates transitions and effective voltage management, which shows the boost converter's role in maintaining optimal system performance under varying irradiance conditions, such as without fault and during fault conditions, as shown in fig 21 and fig 22, respectively.

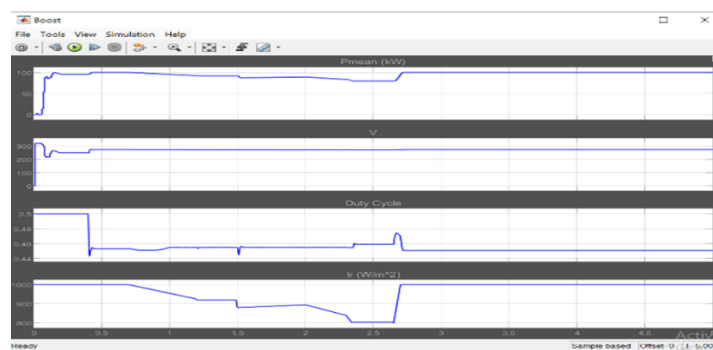

Fig 21. Boost parameters graph for 1000W/m² without fault

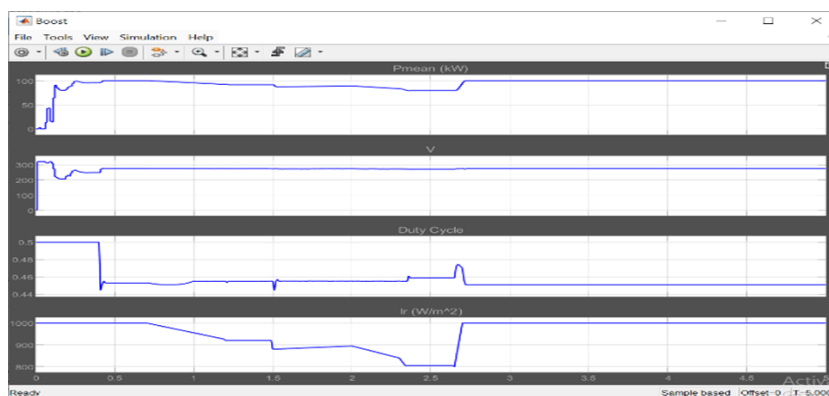

Fig 22. Boost parameters graph for 1000W/m² under fault

Grid V and I Graphs for 1000W/m²

The voltage and current graphs for the grid at 1000 W/m² show consistent voltage levels and minor current fluctuations corresponding to irradiance changes. The voltage and minimal current variations ensure reliable power supply to the grid, even under maximum solar input conditions, as shown in fig 23 and fig 24.

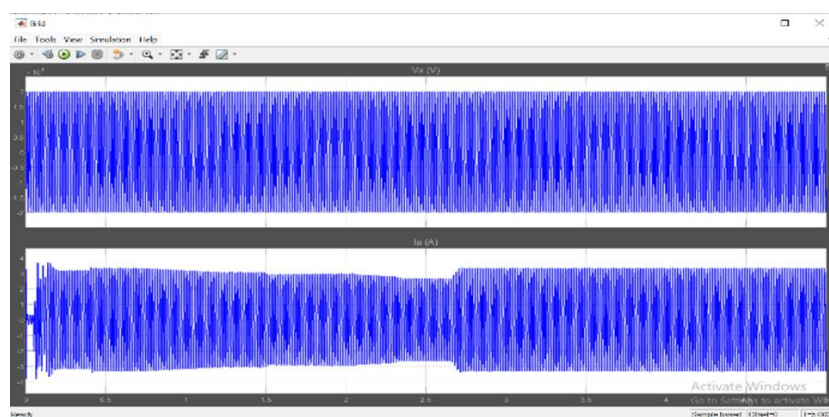

Fig 23. Grid V and I graphs for 1000W/m² without fault

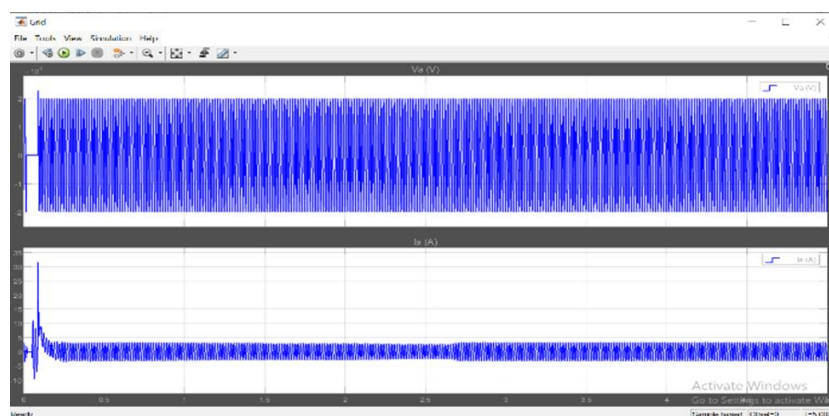

Fig 24. Grid V and I graphs for 1000W/m² under fault

PV Parameters for 1000W/m²

This graph presents the PV system parameters at 1000 W/m², including voltage, current, and power output with and without fault conditions, as shown in fig 25 and fig 26. The parameters show expected variations with increased irradiance, with the system adjusting to maintain optimal performance.

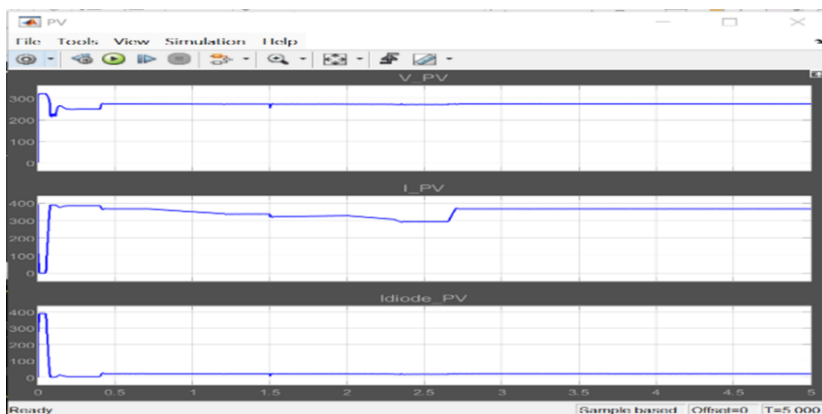

Fig 25. PV parameters graph for 1000W/m² without fault

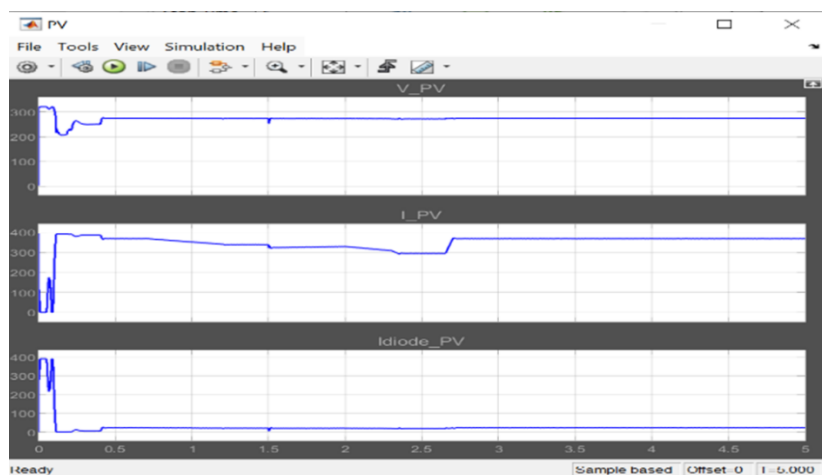

Fig 26. PV parameters graph for 1000W/m² under fault

The model depicting the grid with a three-phase fault block connected illustrates a critical test scenario for assessing transient stability, as given in fig 27. This setup allows for the simulation of severe disturbances, providing insights into the grid's robustness and the effectiveness of various control strategies. The three-phase fault introduces a significant disturbance, challenging the stability of the entire system. Observing the system's response to such faults is crucial for understanding the interplay between different components, especially the inverter control in solar PV systems and the mechanical inertia of synchronous machines. Conversely, the results obtained from the fault simulation and the associated key observations are given in Tables 1 and 2, respectively.

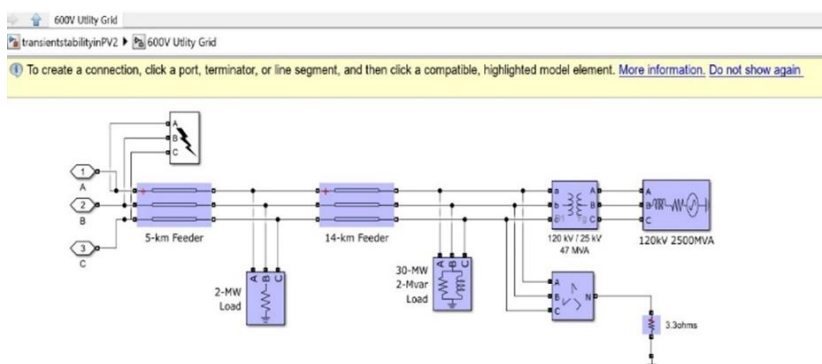

Fig 27. Grid with a three-phase fault block connected

Table 1. Table of results for fault simulations

PARAMETER	IRRADIANCES		
	300W/m ²	500W/m ²	1000W/m ²
Voltage Drop (%)	15%	20%	25%
Current Spike (%)	10%	15%	20%

Power Output Drop	40%	55%	70%
Recovery Time(s)	0.4	0.6	0.9
Voltage Stability	Stabilizes within 0.4s	Stabilizes within 0.6s	Stabilizes within 0.9s
Current Behaviour	Minor fluctuations post-fault	Moderate fluctuations post-fault	Significant fluctuations post-fault
Power Output Stability	Recovers to 85% within 0.4s	Recovers to 80% within 0.6s	Recovers to 75% within 0.9s

Table 2. Key observations from faults simulations

PARAMETER	300 W/m ²	500 W/m ²	1000 W/m ²
PV Output Power (W)	Low	Moderate	High
Grid Voltage Fluctuation (V)	Minor	Moderate	High
Grid Current Fluctuation (A)	Minor	Moderate	High
System Stability	High	Moderate	Low

The fault analysis shows that the performance and stability of PV systems are directly impacted by solar irradiation. Increased voltage dips, current spikes, and recovery durations are indicative of increased system stress at higher irradiance levels. These results support earlier studies by emphasizing the greater susceptibility of high-power photovoltaic systems to transient stability problems.

IV. Conclusion

To guarantee the dependable and long-lasting integration of PV systems into power grids, it is imperative to tackle these issues through efficient fault management and stability enhancement techniques. Nigeria, a nation with significant potential for solar energy, should take particular note of the results. Nigeria may lessen grid vulnerability, cut back on fossil fuel consumption, and advance sustainable energy development by putting the suggested measures into practice. Finally, some recommendations are advised such as implementing advanced fault management technologies like DVRs and FACTS, optimize inverter control strategies using MPPT and advanced control loops, adhere to grid codes and standards for FRT capabilities, develop hybrid energy systems, and upgrade grid infrastructure to support higher levels of RES penetration in order to improve the transient stability of RES-dominated power grids, especially those with large-scale solar PV integration. All of these steps work together to reduce voltage dips, support reactive power, boost grid resilience, improve system response to transient events, and guarantee stable operation in a range of power-generating situations.

References

- [1] M. J. Rahman, "Integration Of Distributed Generation Along With Energy Storage System To Reduce The High Penetration Impacts Of Renewable Energy Sources Into The Power Grid.," Doctoral Dissertation. Université Du Québec En Abitibi-Témiscamingue, 2024.
- [2] E. Villa-Ávila, D. Ochoa-Correa, And P. Arévalo, "Advancements In Power Converter Technologies For Integrated Energy Storage Systems: Optimizing Renewable Energy Storage And Grid Integration," *Process.*, Vol. 13, No. 6, Pp. 1–32, Jun. 2025, Doi: 10.3390/Pr13061819.
- [3] S. Coelho, V. Monteiro, And J. L. Afonso, "Topological Advances In Isolated Dc–Dc Converters: High-Efficiency Design For Renewable Energy Integration," *Sustainability*, Vol. 17, No. 6, Pp. 1–40, Mar. 2025, Doi: 10.3390/Su17062336.
- [4] H. M. Saleh And A. I. Hassan, "The Challenges Of Sustainable Energy Transition: A Focus On Renewable Energy," *Appl. Chem. Eng.*, Vol. 7, No. 2, Pp. 1–24, 2024, Doi: 10.59429/Ace.V7i2.2084.
- [5] M. Marupi, M. Batool, M. Alizadeh, And N. Zanib, "Transient Stability Improvement Of Large-Scale Photovoltaic," Pp. 1–18, 2023.
- [6] J. S. Ali, Y. Qiblawey, A. Alassi, A. M. Massoud, S. M. Muyeen, And H. Abu-Rub, "Power System Stability With High Penetration Of Renewable Energy Sources: Challenges, Assessment, And Mitigation Strategies," *Ieee Access*, Vol. 13, Pp. 39912–39934, 2025, Doi: 10.1109/Access.2025.3546491.
- [7] Z. Song, Y. Li, Y. Li, And Z. Ma, "The Research On Stability Analysis, Challenges, And Coping Strategies Of High-Penetration Renewable Energy Power Systems," *Resour. Data J.*, Vol. 4, Pp. 153–182, May 2025, Doi: 10.50908/Rdj.4.0_153.
- [8] A. Brik, N. E. Y. Kouba, And A. A. Ladjici, "Power System Transient Stability Analysis Considering Short-Circuit Faults And Renewable Energy Sources," In *Engineering Proceedings*, Multidisciplinary Digital Publishing Institute, Sep. 2024, Pp. 1–9. Doi: 10.3390/Engproc2024067042.
- [9] A. Allahham, "The German Northwestern Grid Modelling & Transient Stability: Virtual Synchronous Machines (Vsms) Penetration," Master's Thesis, Universit' At Oldenburg, 2023.
- [10] C. He, H. Geng, K. Rajashekara, And A. Chandra, "Analysis And Control Of Frequency Stability In Low-Inertia Power Systems: A Review," *Ieee/Caa J. Autom. Sin.*, Vol. 11, No. 12, Pp. 2363–2383, 2024, Doi: 10.1109/Jas.2024.125013.
- [11] S. Liu, G. Li, And M. Zhou, "Power System Transient Stability Analysis With Integration Of Dfigns Based On Center Of Inertia," *Csee J. Power Energy Syst.*, Vol. 2, No. 2, Pp. 20–29, Jun. 2016, Doi: 10.17775/Cseejpes.2016.00018.
- [12] S. Gumede, K. Behara, And G. Sharma, "Analytical And Optimisation-Based Strategies For Load Frequency Control In Renewable-Rich Power Systems," *Energies*, Vol. 18, No. 23, Pp. 1–46, Nov. 2025, Doi: 10.3390/En18236295.
- [13] G. M. Njoka, L. Mogaka, And A. Wangai, "Impact Of Variable Renewable Energy Sources On The Power System Frequency Stability And System Inertia," *Energy Reports*, Vol. 12, Pp. 4983–4997, Dec. 2024, Doi: 10.1016/J.Egyr.2024.10.057.
- [14] Q. H. Wu Et Al., "Control And Stability Of Large-Scale Power System With Highly Distributed Renewable Energy Generation: Viewpoints From Six Aspects," *Csee J. Power Energy Syst.*, Vol. 9, No. 1, Pp. 8–14, Jan. 2023, Doi: 10.17775/Cseejpes.2022.08740.
- [15] M. Sites Et Al., "References Definition And Classification Of Power System Stability – Revisited & Extended," No. July, 2021, Doi:

- 10.1109/Tpwsr.2020.3041774.
- [16] S. Albatran, O. Salameh, And S. Harasis, "Modified Transient Stability Evaluation Methodology Of A Multi-Machine Power System Incorporating Renewable Energy Resources Modified Transient Stability Evaluation Methodology Of A Multi-Machine Power System Incorporating Renewable Energy Resources," No. February, 2022, Doi: 10.15866/Iree.V16i6.21225.
- [17] I. Chaerah Gunadin Et Al., "Stability Margin When Wind Turbine Large Scale Penetrated To South Sulawesi-Indonesia Power System Using Optimally Pruned Extreme Learning Machine (Opelm)," In Proceedings Of The 2023 1st International Conference On Advanced Informatics And Intelligent Information Systems (Icai3s 2023), Atlantis Press, Feb. 2024, Pp. 224–234. Doi: 10.2991/978-94-6463-366-5_21.
- [18] F. Belaïd, A. Al-Sarihi, And R. Al-Mestneer, "Balancing Climate Mitigation And Energy Security Goals Amid Converging Global Energy Crises: The Role Of Green Investments," *Renew. Energy*, Vol. 205, Pp. 534–542, Mar. 2023, Doi: 10.1016/J.Renene.2023.01.083.
- [19] H. Hou, W. Lu, B. Liu, Z. Hassanein, H. Mahmood, And S. Khalid, "Exploring The Role Of Fossil Fuels And Renewable Energy In Determining Environmental Sustainability: Evidence From Oecd Countries," *Sustain.*, Vol. 15, No. 3, Pp. 1–13, Jan. 2023, Doi: 10.3390/Su15032048.
- [20] G. Shanmugam, "Fossil Fuels, Climate Change, And The Vital Role Of Co2 Plays In Thriving People And Plants On Planet Earth," *Maden Tetk. Ve Aram. Derg.*, Vol. 175, No. 175, Pp. 167–175, Dec. 2024, Doi: 10.19111/Bulletinofmre.1349959.
- [21] Z. A. Ali, "Cutting-Edge Trends Of Ground Robots Transforming Traditional Agriculture: An Overview And Case Studies," *Instrumentation*, Vol. 12, No. 3, Pp. 15–30, Sep. 2025, Doi: 10.15878/J.Instr.202500291.
- [22] F. Li Et Al., "Enhancing System Reliability And Transient Voltage Stability Through Optimized Power Sources And Network Planning," 2023.
- [23] N. Khadka, R. Paudel, B. Adhikary, A. Bista, And ..., "Transient Stability In Renewable Energy Penetrated Power Systems: A Review," *Proc. Resd 2020 Int. Conf. Role Energy Sustain. Soc. Dev.*, No. December, 2020.
- [24] F. A. S. Neves And S. Member, "Control Of Photovoltaic Inverters For Transient And Voltage Stability Enhancement," Pp. 1–11, 2021, Doi: 10.1109/Access.2021.3066147.
- [25] G. M. Tina, G. Maione, S. Licciardello, And D. Stefanelli, "Comparative Technical-Economical Analysis Of Transient Stability Improvements In A Power System," *Appl. Sci.*, Vol. 11, No. 23, Pp. 1–16, Dec. 2021, Doi: 10.3390/App112311359.
- [26] R. Ma, H. Sun, And L. Qin, "An Emergency Coordinated Control Strategy To Improve The Transient Stability Of A Single-Ended Distribution Network," 2023.
- [27] A. Poulouse And S. Kim, "Transient Stability Analysis And Enhancement Techniques Of Renewable-Rich Power Grids," *Energies*, Vol. 16, No. 5, 2023, Doi: 10.3390/En16052495.
- [28] M. H. M. Jahromi, S. Soleymani, And B. Mozafari, "Optimal Allocation Renewable Energy Sources To Enhance Transient Stability Of Active Distribution Networks," *J. Eng. Sci. Technol. Rev.*, Vol. 15, No. 5, Pp. 179–188, 2022, Doi: 10.25103/Jestr.155.23.
- [29] H. N. A. Al-Kaoaz And A. N. B. Alsammak, "Utilizing Hybrid Renewable Energy Systems For Enhancing Transient Stability In Power Grids: A Comprehensive Review," *J. Eur. Des Syst. Autom.*, Vol. 56, No. 4, Pp. 687–696, 2023, Doi: 10.18280/Jesa.560418.
- [30] R. Mollik Babu, S. S. Alam, A. Islam, And M. D. Kamrul Islam, "Toward Sustainable And Clean Energy Futures: A Techno-Economic Review Of Solar Pv Systems, Challenges, And Opportunities," *Ieee Access*, Vol. 13, Pp. 169720–169757, 2025, Doi: 10.1109/Access.2025.3614771.
- [31] L. Meegahapola, A. Sguarezi, J. S. Bryant, M. Gu, E. R. Conde D., And R. B. A. Cunha, "Power System Stability With Power-Electronic Converter Interfaced Renewable Power Generation: Present Issues And Future Trends," *Energies*, Vol. 13, No. 13, 2020, Doi: 10.3390/En13133441.
- [32] N. Kallou, J. Bos, J. R. Torres, And P. Palensky, "A Fundamental Study On The Transient Stability Of Power Systems With High Shares Of Solar Pv Plants," Pp. 62–86, 2020, Doi: 10.3390/Electricity1010005.
- [33] M. Pertl, T. Weckesser, M. Rezkalla, And M. Marinelli, "Transient Stability Improvement: A Review And Comparison Of Conventional And Renewable-Based Techniques For Preventive And Emergency Control," *Electr. Eng.*, Vol. 100, No. 3, Pp. 1701–1718, 2018, Doi: 10.1007/S00202-017-0648-6.
- [34] H. Sun, K. Jiang, X. Lin, Y. Kang, J. Zhang, And D. Liu, "The Transient Instability Mechanism And Stability-Enhanced LVRT Control For VSC Riding-Through Severe Grid Voltage Sag," No. October 2022, Pp. 2038–2049, 2023, Doi: 10.1049/Rpg2.12747.
- [35] A. Agarala, S. S. Bhat, A. Mitra, D. Zychma, And P. Sowa, "Transient Stability Analysis Of A Multi-Machine Power System Integrated With Renewables," 2022.
- [36] H. Sun, K. Jiang, X. Lin, S. Chen, X. Ji, And D. Liu, "Transient Stability Analysis Of The Standalone Solar-Storage AC Supply System Based On Grid-Forming And Grid-Following Converters During Sudden Load Variation," No. September 2022, Pp. 1286–1302, 2023, Doi: 10.1049/Rpg2.12658.
- [37] R. M. Kamel, "New Technique For Improving Transient Stability Of Standalone Microgrid Using Superconductor Fault Current Limiter," *J. Eng. Res.*, No. May, 2023, Doi: 10.1016/J.Jer.2023.07.009.
- [38] I. Akhtar, S. Kirmani, And M. Jameel, "Reliability Assessment Of Power System Considering The Impact Of Renewable Energy Sources Integration Into Grid With Advanced Intelligent Strategies," *Ieee Access*, Vol. 9, Pp. 32485–32497, 2021, Doi: 10.1109/Access.2021.3060892.
- [39] M. Amir, A. K. Prajapati, And S. S. Refaat, "Dynamic Performance Evaluation Of Grid-Connected Hybrid Renewable Energy-Based Power Generation For Stability And Power Quality Enhancement In Smart Grid," Vol. 10, No. March, Pp. 1–16, 2022, Doi: 10.3389/Fenrg.2022.861282.
- [40] E. Dissanayake, "Research Onion: A Systematic Approach For Designing Research Methodology. Part One," No. February, Pp. 1–7, 2023, Doi: 10.13140/Rg.2.2.24466.12489.
- [41] A. Musundire, "Understanding The Research Onion And Its Application In Educational Leadership And Management Research: Making Use Of Saunders' Research Model," *Igi-Global Sci. Publ.*, Pp. 355–384, Jan. 2025, Doi: 10.4018/979-8-3693-9425-0.Ch015.