

Solar Powered Auto Intensity Control Of Street Lights

Amit Bhardwaj, Mangesh Deshmukh, Prabahan Baruah

Abstract:

In the present system, mostly lightning up of highways is done through High Intensity Discharge Lamps (HID), whose energy consumption is high. It's intensity cannot be controlled according to the requirement so there is a need to switch on to alternative method of lightning system i.e by using LEDs (Light Emitting Diodes). This system is built to overcome the present drawback of HID lamps. This system demonstrates the usage of the LEDs as the light source powered through solar panel with its variable intensity control as per the requirement. A cluster of LEDs are used to form a street light. The ATMEGA 16 contains programmable instructions which controls the intensity of LEDs based on the LDR sensor signals generated. The intensity of LEDs can be varied depending on the requirement of light on highways, thus saving electrical energy.

Date of Submission: 14-10-2023

Date of acceptance: 24-10-2023

I. Introduction

In a worldwide scene of global warming and increasing costs of energy, power saving and sustainable development comes under some of the main requirements in design and research tasks. In lightning, these requirements are fulfilled by developing new light sources (high-brightness LEDs, low-power metal halide lamps) by using enhanced control techniques (digital control) and by optimising the system operation (dimming capabilities, preheating of filaments if possible, etc.)

High-brightness LEDs are feasible alternative for some types of lightning systems due to the sustained increase of the luminous efficiency as well as the long operating life (up to 100 000 hours) of these devices. To attain such operating life level, the intensity of the LEDs must be controlled. The control of intensity will save the unnecessary usage of lights during day time and even at non-peak hours during night time. It is not possible to control the intensity of HID lamps. Hence, it results in unnecessary usage of energy.

Light emitting diodes (LEDs) are about to gradually substitute cold cathode fluorescent lamps. In large-scale LCD panels, multistring LED lights are required to provide sufficient lightning. In addition, two novel display techniques, multi flashing colour sequential display and area control, can be achieved when multistring LED lights are adopted. Figure 1 shows light emitting diode. Recently LEDs have been applied to liquid crystal display (LCD) backlight or display panel, signage, and general-purpose lightning due to the rapid progress achieved in the solid-state lightning technology. Compared with existing conventional lightning sources such as energy –inefficient incandescent lamps and mercury based fluorescent lamps, LEDs have relatively longer lifetime in the range of 80 000-100 000 hours. LEDs available in the market are encapsulated with less glass, which significantly improves their reliability and safety to the handler. Besides mercury-free LEDs are environment friendly and can be disposed safely at the end of their lifetime. LEDs also have flicker-free, smooth-dimming, low-voltage operation, and good colour rendering properties.

Presently, the power ratings of individual LED devices are a few watts, limited by the packaging technology and heat dissipation. To obtain sufficient luminance for some high-power applications, such as streetlight and large-scale LCD panels, many LEDs are connected in parallel LED strings. The general photo electro thermal (PET) theory also indicates that a distributed LED system based on a plurality of relatively low-power LEDs can have advantages over a concentrated system consisting of a small number of high-power LEDs for the same system power. Therefore, using LED strings in parallel has been a common practice.

Multiple LED lamps are usually connected in parallel for obtaining enough lightning levels. In addition, dimming control is often needed to regulate lightning levels for human needs as well as to achieve

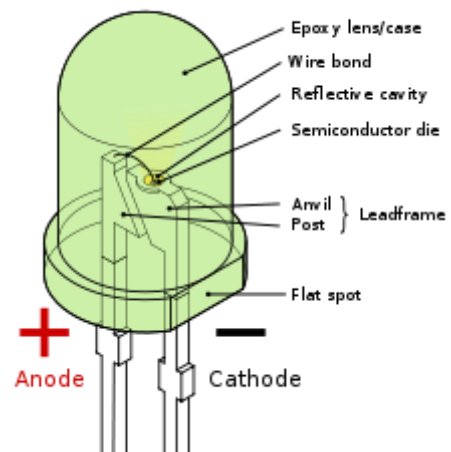

Fig.1. Light Emitting Diode

energy saving. Multiple methods can be used to regulate the intensity of the LEDs but the most convenient method would be by the use of microcontroller. By using programming and intensity of light of the environment, we can control the intensity of the LEDs by using multiple sensors and microcontroller.[5]

The use of parallel LED strings inevitably leads to current imbalance problem due to the LED parameter variations, aging, and temperature changes, which will in turn affect the luminous intensity and even colour in each string. Most importantly, if the current imbalance causes one or more LED strings to exceed their rated current values, the lifetime of the LED (and hence, the LED system) will be drastically reduced.

II. Literature Survey

Recently even BMC is planning to replace around 1.32 lakh streetlights with LED. A pilot project is being planned for Colaba, Bandra, & Malad. There are plans to cover the entire city with LED lights and the first batch will be replaced in marine drive. Installation of LED lights will reduce the consumption of 10 crore units per year. BMC currently spends Rs. 164 crore annually on the street lights and their power consumption. Currently 39,603 street lights are being operated by them and this project will be very cost effective and will save almost 50% of the power consumption.

The idea of our project came from the news of the BMC and the replacement will not solve the entire problems. LEDs are point light source, it does not offer the diffused light like HID lamps and the intensity of the light is high and concentrated at one place. So, this can be overcome by proper arrangement of lights and the overheating and current imbalance problems and wastage of energy problems can be overcome by using the microcontroller and various sensors explained further.

A number of papers published in IEEE journals and conferences are reviewed, most of the literature discussed about Solar Powered Auto Intensity Control of Street Lights is on the key points discussed for the establishment of LEDs completely on the streets. Many people have worked on it and still working on the increase in efficiency of LEDs and many have highlighted on the advantages of LEDs. No UV or IR radiations are emitted from it. The filament used in the HID lamps is also not present. So, it reduces the cost of wires used in it. The size of the LED is compact and the intensity of the light is very high.

It reduces the energy consumption upto 50% when connected to AC source and upto 90% when connected to solar power source. The energy can be saved up to 8% when used in heavy traffic and up to 50% when used in less traffic. Also, use of solar power source enables the implementation of batteries, which can be used to get charged and used during night time, saving more energy.

III. Introduction to LED

A light-emitting diode (LED) is a two-lead semiconductor light source. It is a pn-junction diode, which emits light when activated. When a suitable voltage is applied to the leads, electrons are able to recombine with electron holes within the device, releasing energy in the form of photons. This effect is called electroluminescence, and the colour of the light (corresponding to the energy of the photon) is determined by the energy band gap of the semiconductor. An LED is often small in area (less than 1 mm²) and An LED is often small in area (less than 1 mm²) and integrated optical components may be used to shape its radiation pattern, appearing as practical electronic components in 1962, the earliest LEDs emitted low-intensity infrared light. Infrared LEDs are still frequently used as transmitting elements in remote-control circuits, such as those in remote controls for a wide variety of consumer electronics. The first visible-light LEDs were also of low intensity, and limited to red. Modern LEDs are available across the visible, ultraviolet, and infrared wavelengths, with very high brightness.

In the last few years LED technology experienced a very fast and important growth, superseding the bulb technology in automotive lighting applications. The adoption of LEDs in place of bulbs permits to have about fivetimes less power consumption at equal output lighting intensity. LEDs have reached quality and reliability factors that permit their use in automotive harsh environment and in addition their cost is decreasing. In a worldwide scene of global warming and increasing costs of energy, power saving and sustainable

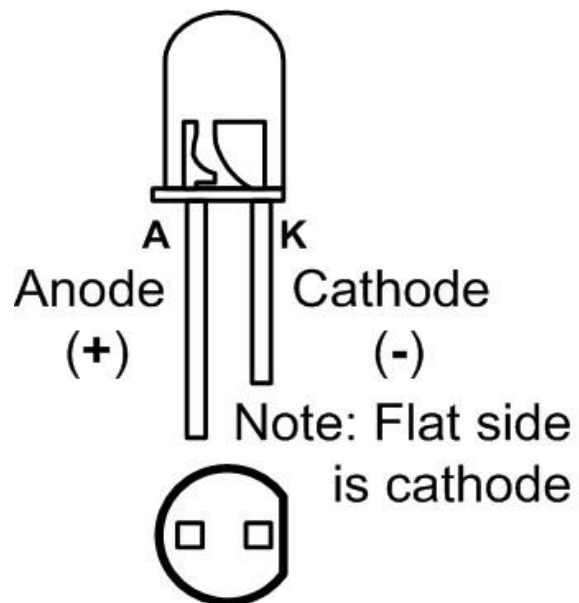

Fig 2. Symbolic diagram of LED

development come some of the main requirements in design and research tasks. In lighting, these requirements are fulfilled by developing new light sources (high-brightness LEDs, low-power metal halide lamps) by using enhanced control techniques(digital control) and by optimizing the system operation (dimming capabilities, preheating of filaments if possible, etc.)

Operation

The LED consists of a chip of semiconducting material doped with impurities to create a p-n junction. As in other diodes, current flows easily from the p-side, or anode, to the n-side, or cathode, but not in the reverse direction.

Charge-carriers electrons and holes flow into the junction from electrodes with different voltages. When an electron meets a hole, it falls into a lower energy level and releases energy in the form of a photon. Light is a form of energy that can be released by an atom. It is made up of many small particle-like packets that have energy and momentum but no mass. These particles, called photons, are the most basic units of light.

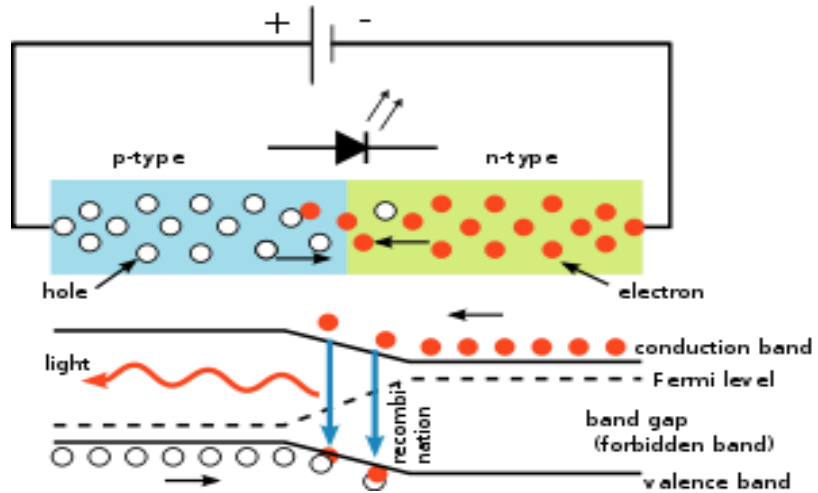

Fig 3. The inner workings of an LED, showing circuit (top) and band diagram (bottom)

For an electron to jump from a lower orbital to a higher orbital, something has to boost its energy level. Conversely, an electron releases energy when it drops from a higher orbital to a lower one. This energy is released in the form of a photon.

Free electrons moving across a diode can fall into empty holes from the P-type layer. This involves a drop from the conduction band to a lower orbital, so the electrons release energy in the form of photons. This happens in any diode, but you can only see the photons when the diode is composed of certain material. The atoms in a standard silicon diode, for example, are arranged in such a way that the electron drops a relatively short distance. As a result, the photon's frequency is so low that it is invisible to the human eye -- it is in the infrared portion of the light spectrum. Visible light-emitting diodes (VLEDs), such as the ones that light up numbers in a digital clock, are made of materials characterized by a wider gap between the conduction band and the lower orbitals. The size of the gap determines the frequency of the photon -- in other words, it determines the colour of the light.

Colours and Material

Conventional LEDs are made from a variety of inorganic semiconductor materials. The following table shows the available colors with wavelength range, voltage drop and material:

	Colour	Wavelength [nm]	Voltage drop [ΔV]	Semiconductor material
	Infrared	$\lambda > 760$	$\Delta V < 1.63$	Gallium arsenide (GaAs) Aluminum gallium arsenide (AlGaAs)
	Red	$610 < \lambda < 760$	$1.63 < \Delta V < 2.03$	Aluminium gallium arsenide (AlGaAs) Gallium arsenide phosphide (GaAsP) Aluminium gallium indium phosphide (AlGaInP) Gallium(III) phosphide (GaP)
	Orange	$590 < \lambda < 610$	$2.03 < \Delta V < 2.10$	Gallium arsenide phosphide (GaAsP) Aluminium gallium indium phosphide (AlGaInP) Gallium(III) phosphide (GaP)
	Yellow	$570 < \lambda < 590$	$2.10 < \Delta V < 2.18$	Gallium arsenide phosphide (GaAsP) Aluminium gallium indium phosphide (AlGaInP) Gallium(III) phosphide (GaP)

Green	$500 < \lambda < 570$	$1.9 < \Delta V < 4.0$	Traditional Gallium(III) phosphide (GaP) Aluminium gallium indium phosphide (AlGaInP) Aluminium gallium phosphide (AlGaP) Pure green: Indium gallium nitride (InGaN) / Gallium(III) nitride (GaN)
Blue	$450 < \lambda < 500$	$2.48 < \Delta V < 3.7$	Zinc selenide (ZnSe) Indium gallium nitride (InGaN) Silicon carbide (SiC) as substrate Silicon (Si) as substrate—under development
Violet	$400 < \lambda < 450$	$2.76 < \Delta V < 4.0$	Indium gallium nitride (InGaN)
Purple	Multiple types	$2.48 < \Delta V < 3.7$	Dual blue/red LEDs, blue with red phosphor, or white with purple plastic
White	Broad spectrum	$\Delta V = 3.5$	Blue/UV diode with yellow phosphor

Advantages

- (a) **Efficiency:** LEDs emit more lumens per watt than incandescent light bulbs. The efficiency of LED lighting fixtures is not affected by shape and size, unlike fluorescent light bulbs or tubes.
- (b) **Colour:** LEDs can emit light of an intended colour without using any colour filters as traditional lighting methods need. This is more efficient and can lower initial costs.
- (c) **Size:** LEDs can be very small (smaller than 2 mm²) and are easily attached to printed circuit boards.
- (d) **On/Off time:** LEDs light up very quickly. A typical red indicator LED will achieve full brightness in under a microsecond. LEDs used in communications devices can have even faster response times.
- (e) **Cycling:** LEDs are ideal for uses subject to frequent on-off cycling, unlike incandescent and fluorescent lamps that fail faster when cycled often, or High-intensity discharge lamps (HID lamps) that require a long time before restarting.
- (f) **Dimming:** LEDs can very easily be dimmed either by pulse-width modulation or lowering the forward current. This pulse-width modulation is why LED lights, particularly headlights on cars, when viewed on camera or by some people, appear to be flashing or flickering. This is a type of stroboscopic effect.
- (g) **Lifetime:** LEDs can have a relatively long useful life. One report estimates 35,000 to 50,000 hours of useful life, though time to complete failure may be longer. Fluorescent tubes typically are rated at about 10,000 to 15,000 hours, depending partly on the conditions of use, and incandescent light bulbs at 1,000 to 2,000 hours. Several DOE demonstrations have shown that reduced maintenance costs from this extended lifetime, rather than energy savings, is the primary factor in determining the payback period for an LED product.
- (h) **Shock resistance:** LEDs, being solid-state components, are difficult to damage with external shock, unlike fluorescent and incandescent bulbs, which are fragile.

Disadvantages

- (a) **High initial price:** LEDs are currently more expensive, price per lumen, on an initial capital cost basis, than most conventional lighting technologies. As of 2012, the cost per thousand lumens (kilolumen) was about \$6. The price was expected to reach \$2/kilolumen by 2013. At least one manufacturer claims to have reached \$1 per kilolumen as of March 2014. The additional expense partially stems from the relatively low lumen output and the drive circuitry and power supplies needed.
- (b) **Temperature dependence:** LED performance largely depends on the ambient temperature of the operating environment – or "thermal management" properties. Over-driving an LED in high ambient temperatures may result in overheating the LED package, eventually leading to device failure. An adequate heat sink is needed to maintain long life. This is especially important in automotive, medical, and military uses where devices must operate over a wide range of temperatures, which require low failure rates. Toshiba has produced LEDs with an operating temperature range of -40 to 100 °C, which suits the LEDs for both indoor and outdoor use in applications such as lamps, ceiling lighting, street lights, and floodlights.
- (c) **Voltage sensitivity:** LEDs must be supplied with the voltage above the threshold and a current below the rating. Current and lifetime change greatly with small changes in applied voltage.
- (d) **Light quality:** Most cool-white LEDs have spectra that differ significantly from a black body radiator like the sun or an incandescent light. The spike at 460 nm and dip at 500 nm can cause the colour of objects to be perceived differently under cool-white LED illumination than sunlight or incandescent sources, due to metamerism, red surfaces being rendered particularly badly by typical phosphor-based cool-white LEDs.

However, the **Area light source**: Single LEDs do approximate a point source of light giving a spherical light distribution, but rather a lambertian distribution. So LEDs are difficult to apply to uses needing a spherical light field; however, different fields of light can be manipulated by the application of different optics or "lenses". LEDs cannot provide divergence below a few degrees. In contrast, lasers can emit beams with divergences of 0.2 degrees or less.

- (e) **Electrical polarity**: Unlike incandescent light bulbs, which illuminate regardless of the electrical polarity, LEDs will only light with correct electrical polarity. To automatically match source polarity to LED devices, rectifiers can be used.
- (f) **Blue hazard**: There is a concern that blue LEDs and cool-white LEDs are now capable of exceeding safe limits of the so-called blue-light hazard as defined in eye safety specifications such as ANSI/IESNA RP-27.1-05: Recommended Practice for Photo-biological Safety for Lamp and Lamp Systems.
- (g) **Blue pollution**: Because cool-white LEDs with high colour temperature emit proportionally more blue light than conventional outdoor light sources such as high-pressure sodium vapour lamps, the strong wavelength dependence of Rayleigh scattering means that cool-white LEDs can cause more light pollution than other light sources. The International Dark-Sky Association discourages using white light sources with correlated colour temperature above 3,000 K.
- (h) **Efficiency droop**: The luminous efficacy of LEDs decreases as the electrical current increases. Heating also increases with higher currents which compromises the lifetime of the LED. These effects put practical limits on the current through an LED in high power applications.
- (j) **Impact on insects**: LEDs are much more attractive to insects than sodium-vapour lights, so much so that there has been speculative concern about the possibility of disruption to food webs.

IV. Microcontroller

A **microcontroller** (sometimes abbreviated μC or **MCU**) is a small computer on a single integrated circuit containing a processor core, memory, and programmable input/output peripherals. Program memory in the form of Ferroelectric RAM, NOR flash or OTP ROM is also often included on chip, as well as a typically small amount of RAM. Microcontrollers are designed for embedded applications, in contrast to the microprocessor used in personal computers or other general purpose applications.



Fig 4. The die from an Intel 8742, an 8-bit microcontroller that includes a CPU running at 12MHz, 128 bytes of RAM, 2048 bytes of EPROM, and I/O in the same chip.

Microcontrollers are used in automatically controlled products and devices, such as automobile engine control systems, implantable medical devices, remote controls, office machines, appliances, power tools, toys and other embedded systems. By reducing the size and cost compared to a design that uses a separate microprocessor, memory, and input/output devices, microcontrollers make it economical to digitally control even more devices and processes

Microcontroller Applications

Microcontrollers are intended for embedded devices, in comparison to the micro-processors which are used in PCs or other all-purpose devices. Microcontrollers are employed in automatically managed inventions and appliances like- power tools, implantable medical devices, automobile engine control systems, , office machines, remote controls appliances, toys and many more embedded systems.

Advantages

- (a) Microcontrollers act as a microcomputer without any digital parts.
- (b) As the higher integration inside microcontroller reduce cost and size of the system.
- (c) Usage of microcontroller is simple, easy for troubleshoot and system maintaining.

Disadvantages

- (a) Microcontrollers have got more complex architecture than that of microprocessors.
- (b) Only perform limited number of executions simultaneously.

Block Diagram

The Fig 6 depicts the block diagram of the proposed project. Although our main objective is to conserve electricity and use renewable energy sources,(solar power in this case), a transformer supply can be used in case of solar unavailability, as shown in Fig 7.

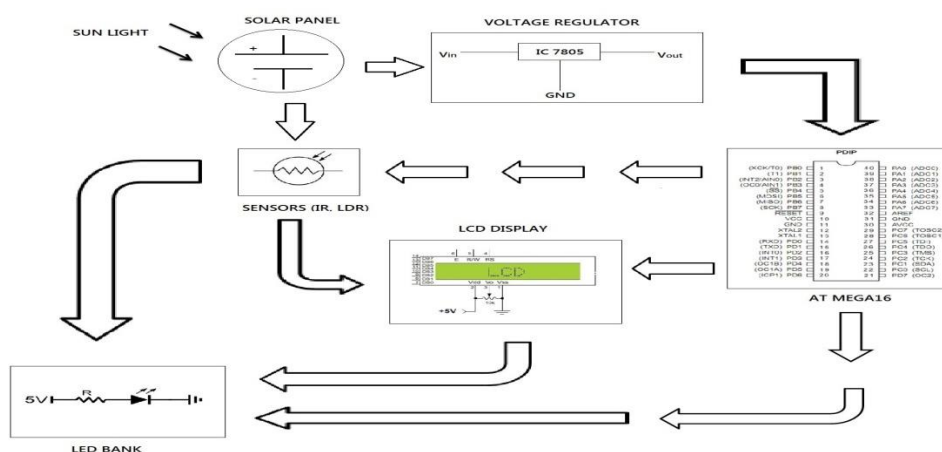

Fig. 6. Block Diagram In Case of Solar Availability

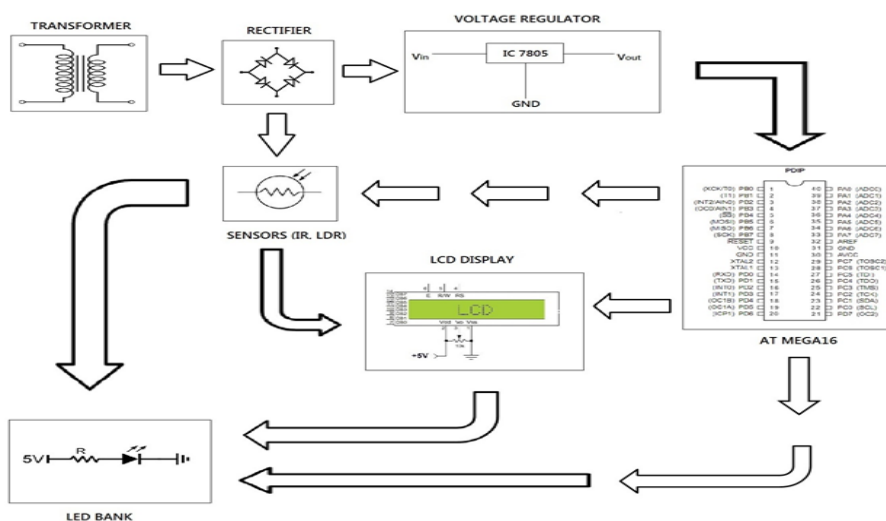

Fig. 6. Block Diagram In Case of Solar Unavailability

The proposed model comprises of the following main parts:

Power Supply

When working with electronics, you always need one basic thing: Power. In every electronic circuit power supply is required. Considering modern power requirement, we've used solar power as a supply to the project. *Solar pane* refers either to a photovoltaics (PV) module, or to a set of solar photovoltaics modules electrically connected and mounted on a supporting structure. Solar panels can be used as a component of a larger photovoltaic system to generate and supply electricity in commercial and residential applications. Each module is rated by its DC output power under standard test conditions, and typically ranges from 100 to 320 watts. The efficiency of a module determines the area of a module given the same rated output – an 8% efficient 230 watt module will have twice the area of a 16% efficient 230 watt module. If solar energy is not available, then transformer and rectifier, as shown in Fig 4.2, are used to provide desired power supply to the model. The proper working of each and every component requires the exact amount of voltage and current to be supplied to it. If the power exceeds its limit, it can be fatal. The power supply comprises of mainly 3 components:

- (i) Transformer (1- ϕ , 230V).
- (ii) Bridge Rectifier.
- (iii) Voltage Regulator.

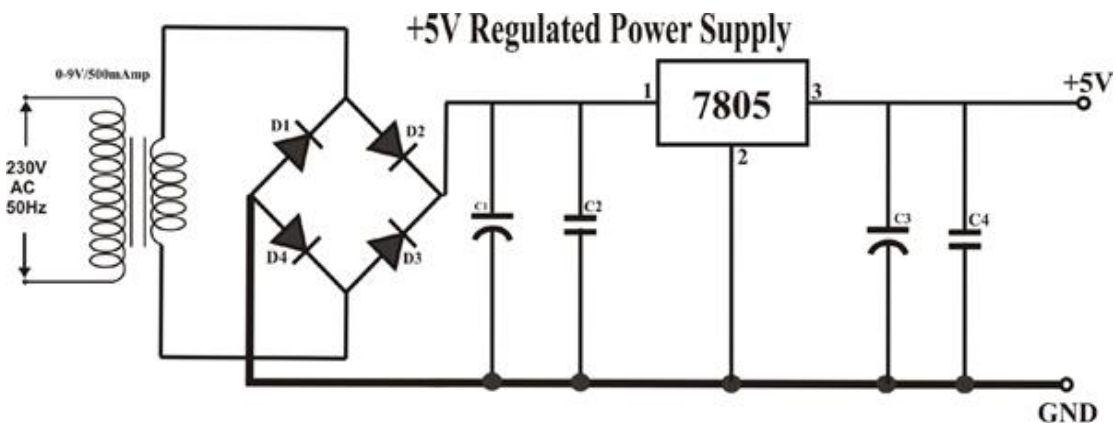

Fig. 6. Power supply Circuit Diagram

Sensors Sensors are used in any electronic device because it is very important for the device to sense a few parameters and respond in real time. They make the device self-sustaining. Innovative technologies in sensing circuits have made development of devices which are smarter as well as better than their contemporaries. In our project we have used two types of sensors:

Light dependent resistor (LDR) In this sensor, two Cadmium Sulphide (CdS) photoconductive cells with spectral responses similar to that of the human eye are present. The cell resistance falls with increasing light intensity. The LDR's have a particular property that they remember the lighting conditions in which they have been stored. This memory effect can be minimised by storing the LDR's in light prior to use. Light storage reduces equilibrium time to reach steady resistance values. Fig 12 represents the LDR circuit symbol. Applications include smoke detection, automatic light control, burglar alarm systems etc. The LDR has a wide spectral response, low cost and wide ambient temperature range. The ratings of the sensing circuit are as follows:

- | | | |
|--|---|-----------------------------|
| (i) Voltage, ac or dc peak | : | 100V |
| (ii) Current | : | 5mA |
| (iii) Power dissipation at 25deg Celsius | : | 50mW. |
| (iv) Operating temperature range | : | -25 deg to +75 deg Celsius. |

LED Bank

A light-emitting diode (LED) is a two-lead semiconductor light source. It is a pn-junction diode, which emits light when activated. When a suitable voltage is applied to the leads, electrons are able to recombine with electron holes within the device, releasing energy in the form of photons. This effect is

called electroluminescence, and the colour of the light (corresponding to the energy of the photon) is determined by the energy band gap of the semiconductor

V. Results & Conclusions

In our project, we have proposed auto intensity control of street lights. The operation and principle have been explained in detail. According to it, as the light intensity is ≥ 200 Lux, LED doesn't glow. As the light intensity goes below 200 Lux, LED's glow with 50% intensity. In scenarios where intensity of light is zero or extremely less (night or cloudy days), LED's glow with full brightness. In cases where intensity of light is low, but the circuit has detected an obstacle, LED's, in such a case will glow with full brightness, irrespective of the intensity of light. The solar energy is one of the important and major renewable sources of energy and has also proven it useful in functioning of applications like street lights. The charge control is necessary in order to achieve safety and increase the capacity of the battery. In cities, currently thousands of street lights are operated and the yearly electricity maintenance cost is very high. The initial cost and maintenance can be the drawbacks of this project. With the advancements in technology and good resource planning the cost of the project can be cut down. Thus, this project can be resourceful and a smart alternative for widely used halogen Lamp Street lights in our country

S no.	Obstacle	Intensity	LED Status
1.	Present	<200 Lux	100% Intensity
2.	Absent	<200 Lux	100% Intensity
3.	Present	≥ 200 Lux	50% Intensity
4.	Absent	≥ 200 Lux	50% Intensity

Table 1. Final Results Of The Proposed Project

Future Scope

The solar powered auto intensity of street lights can control the electric charge and intensity of lights. This project can be enhanced by using Dusk to Drawn switch with an advanced technology to overcome the flows of existing timer based products and photo sensor based products.

The LED lights used can be made to diffuse its point source light by using glasses in front of them. The solar panel used, can be connected to a battery or series of battery for continuous power supply. And as we are measuring traffic density according to that we can control the traffic of the road and can avoid a traffic jam problem which implies avoidances of accidents.

References

- [1] W. C. Su And C. L. Chen, "Zvs For Pt Backlight Inverter Utilizing High-Order Current Harmonic," Ieee Trans. Power Electron., Vol. 23, No. 1, Pp.4-10, Jan. 2008.
- [2] F. J. Azcondo, F. J. Diaz, C. Branas And R. Casanueva "Microcontroller Power Mode Stabilized Power Factor Correction Stage For High Intensity Discharge Lamp Electronic Ballast", Ieee Trans. Power Electron. Vol. 22, No.3, Pp. 845-853, May 2007 (Special Section On Lightingapplications).
- [3] C. Y. Wu, T. F. Wu, J. R. Tsai, Y. M. Chen, And C. C. Chen, "Multistring Led Backlight Driving System For Lcd Panels With Colour Sequential Display And Area Control" Ieee Trans. Ind. Electron, Vol. 55, No. 10, Pp. 3791-3800, Oct. 2008.
- [4] S. K. Kim, H. S. Han, Y. J. Woo And G. H. Cho, "Detection And Regulation Of Ccfl Current And Open-Lamp Voltage While Keeping Floating Condition Of The Lamp", Ieee Trans. Ind. Electron., Vol. 53, No. 2, Pp. 707-709, Apr. 2006.
- [5] Electrolytic Capacitors Application Guide, Evoxrifa, 2001.
- [6] Light Dependent Resistor Data Sheet By Rs Components, An Electro-Components Company Issued March 1997 232-3816.
- [7] Atmel Corporation, At Mega16. At Mega 16l, Preliminary Complete Datasheet, 2490g-Avr-03/04. 2001. www.Atmel.Com/Images/Doc2466.Pdf
- [8] How To Create A Printed Circuit Board (Pcb), By John Kelly, Department Of Electrical & Computer Engineering, Michigan State University www.Egr.Msu.Edu/Eceshop/Pdf/An_Pcb_T23.Pdf
- [9] A Minimal Infrared Obstacle Detection Scheme, C. Ronald Kube, Department Of Computing Science University Of Alberta Edmonton, Canada International Journal Of Advanced Research In Electrical, Electronics And Instrumentation Engineering Vol. 2, Issue 4, April 2013, Pp. 1430-1434