

## Simulation of a Space Vector PWM Controller for a Five-Level Voltage-Fed Inverter Motor Drive

Ankit Modi<sup>1</sup>, Dhaval Patel<sup>2</sup>, Purv Mistry<sup>3</sup>, Chintan Patel<sup>4</sup>

<sup>1</sup>School of Electrical Eng., VIT University, Vellore, India.

<sup>2</sup>School of Electrical Eng., VIT University, Vellore, India

<sup>3</sup>Institute of Technology, Nirma University, Ahmedabad, India.

<sup>4</sup>Institute of Technology, M.S. University, Vadodara, India.

**Abstract:** As per the power quality IEEE 519-1992 STD the inverter output voltage should follow limit of harmonics standards specified. For the low power demand sine pulse width techniques has proven good performance. But as the power demand increases it becomes necessity to replace switching technique SPWM with the SVPWM. In order to implement SVPWM for multilevel inverter we find the difficulty in determining the location of reference vector, calculation of ON time and calculation and estimation of switching states. Thus with the increase in the number of level, the complexity increases. In the proposed scheme, five-level space vector PWM inverter is easily implemented as conventional two-level space vector PWM inverter. Therefore, the proposed method can also be applied to multilevel inverters. The design of LC filter for the reduction in harmonics is shown

**Keywords:** Multilevel inverter, space vector pulse width modulation (SVPWM), switching state, two-level inverter.

### I. Introduction

Multilevel converters have the later years been looked upon as a good choice for medium- and high-voltage applications. It was first presented in [1]. Before the introduction of multilevel converters the traditional solution has been to connect semiconductors in series to withstand the high voltages. This requires fast switching to avoid unequal voltage sharing between the devices, which could lead to a breakdown. Multilevel converters have the advantage of clamping the voltages, which prevents the need of fast switching. MLC also have a smoother output voltage than traditional two-level converters. As machines load demand are increasing, multilevel converters can be well suited in such applications.

The most popular multilevel converter and the one that will be studied in this paper is the diode clamped five-level converter. One of the challenges with the five-level converter is the increased complexity in the control of it. A lot of research have been done on this converter topology and a numerous of control methods have been presented in the literatures.

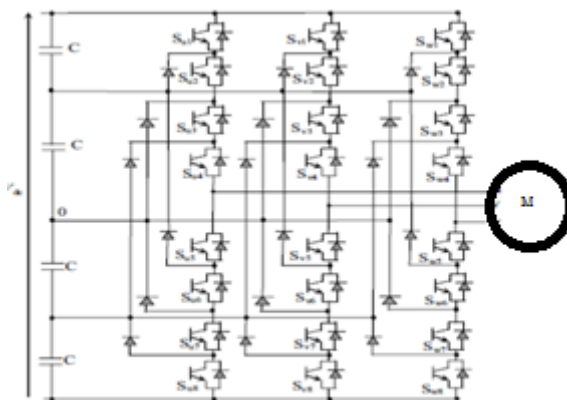

Fig.1 topology of 5 level diode clamped inverter Fed Motor



Total time is equal to the switching time given by eq.3

$$T_a = t_a + t_b + t_o \quad - (2)$$

$$v_{\alpha o}^s T_s = t_a + 0.5t_b \quad - (3)$$

$$v_{\beta o}^s T_s = ht_b \quad - (4)$$

The  $t_a$  is calculated using eq. 5

$$t_a = T_s \left[ v_{\alpha o}^s - \frac{v_{\beta o}^s}{2h} \right] \quad - (5)$$

The  $t_b$  is calculated using eq. 6

$$t_b = T_s \left[ \frac{v_{\beta o}^s}{h} \right] \quad - (6)$$

The  $t_o$  is calculated using eq. 7

$$t_o = T_s - t_a - t_b \quad - (7)$$

Fig 4 shows the method of on time estimation of five-level inverter. In five-level inverter, sector is divided in sixteen triangles for easy calculation of time. Triangles are divided into two groups of type1 and type2. Type1 triangle base is parallel with base of the sector while type2 triangle base side is opposite to that.

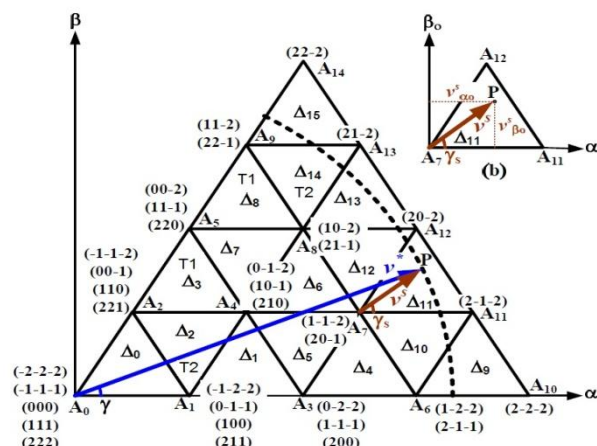

Fig.4 Space vector diagram for 5 level inverter in terms of 2 level inverter

For estimation of “on time” we know that triangle side length is unity and its height  $h (= \sqrt{3}/2)$ . In the above figure reference vector is shown with value of  $v^*$  and it is making angle  $\gamma$  to the axis of the  $\alpha - \beta$  plane. As shown in the figure to decide the “on time” we shift the reference vector in the particular triangle by considering it's as sector and then get the small vector with  $(\alpha_0, \beta_0)$ . Now for the estimation we get the volt-second balance of the small vector  $v^s$  which is equal to the main vector. By using the above volt-second balance equations we can directly get the switching times of nearest vectors.

For getting volt-second balance for vector in any sector of the five-level inverter, first we have to get in which triangle reference vector is falling. After that as explained above we can use small vector concept and equations we get the switching time.

2.2 Block Diagram

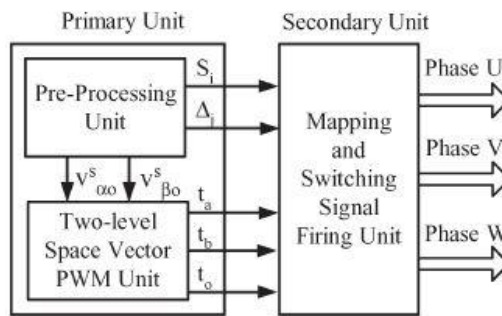

Fig. 5 block diagram for SVPWM implementation

There are 2 units in the proposed diagram, primary unit and secondary unit. Primary unit is of DSP or microcontroller. The main function of primary unit is to determine the vector address  $v^s$  in 2D space and to determine the position of the vector location in the triangle for a respective sector. Based on the location of vector, the “on time” is calculated. The role of secondary unit is to generate the pulse for the inverter based on the “on time”, which was generated by the primary unit. For the triangle vertex, there will always be he redundancies. Thus the scheme will consider any triangle vertex zero vectors and switching sequence will be calculated accordingly.

2.2.1 Role of primary unit

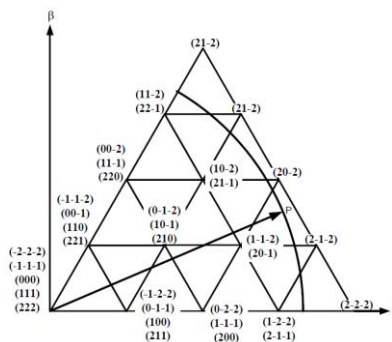

Fig.6 Space vector diagram of 5 level inverter

For the use of SVPWM, we have to first determine the sector and the angle. The below equation gives the sector and angle

$$S_i = \text{int}\left(\frac{\theta}{60}\right) + 1 \quad - (8)$$

$$\gamma = \text{rem}\left(\frac{\theta}{60}\right) \quad - (9)$$

Here the  $\theta$  represents the angle vector for 2D axis.

Here by using PARK’s transformation we are getting 2D values from 2D values. By using the 2D values we are obtaining the values of K1 and K2.

$$K_1 = \text{int}\left(v_\alpha + \frac{v_\beta}{\sqrt{3}}\right) \quad - (10)$$

$$K_2 = \text{int}\left(\frac{v_\beta}{h}\right) \quad - (11)$$

Small vector co-ordinates are represented by  $v_{\alpha i}$  and  $v_{\beta i}$ , which is given by the following equation,

$$v_{\alpha i} = v_\alpha - K_1 + 0.5K_2 \quad - (12)$$

$$v_{\beta i} = v_\beta - K_2h \quad - (13)$$

From the values of  $v_{\alpha i}$  and  $v_{\beta i}$  we are determining the location of the triangle.  
 For type 1 triangle it is given by,

$$\Delta_j = K_1^2 + 2K_2$$

For type 2 triangle it is given by,

$$\Delta_j = K_1^2 + 2K_2 + 1$$

**2.2.2 Role of secondary unit**

From the primary unit, we obtain the sector number, the respective triangle number location and the on-time. By obtaining the above values the secondary unit generates the switching sequence for the 5 level inverter.

Vertex	A1	A2	A3	A1	A2	A3	A1
S <sub>U</sub>	0	1	1	1	2	2	2
S <sub>V</sub>	-1	-1	0	0	0	1	1
S <sub>W</sub>	-2	-2	-2	-1	-1	-1	0
On-time	t <sub>o</sub>	t <sub>a</sub>	t <sub>b</sub>	t <sub>o</sub>	t <sub>a</sub>	t <sub>b</sub>	t <sub>o</sub>

**Table 1.** Switching sequence for Δ6 for 5 level inverter

In the secondary unit, there will be look up table in the memory of it. This look up table will provide the information of the switching sequence

The table 1 gives the information for the triangle number 6 of a sector 1.

The flowchart for the implementation of SVPWM for 5 level inverter is given below

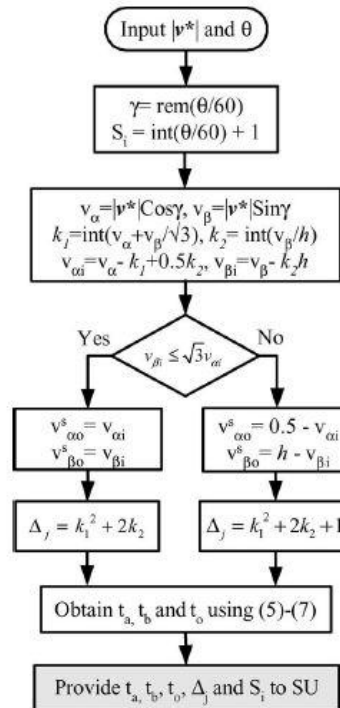

**Fig. 7** Flowchart for 5 level SVPWM

**III. Simulated results:**

The following algorithm was implemented on a dSPACE. The proposed algorithm can be easily implemented on a DSP module.

The fig. 8 and fig.9 shows the current and line voltage waveform respectively. The dc link voltage is 400 V, modulation index is 0.85, switching frequency is 3 kHz and the fundamental frequency is 50Hz.

The THD waveform was obtained up to 10kHz, and the THD obtained was 16.5% but with the usage of LC filter, the THD obtained was 0.28, with the usage of minimum value of L is 2.5mh and C is 100 uF value. As shown in fig. 10

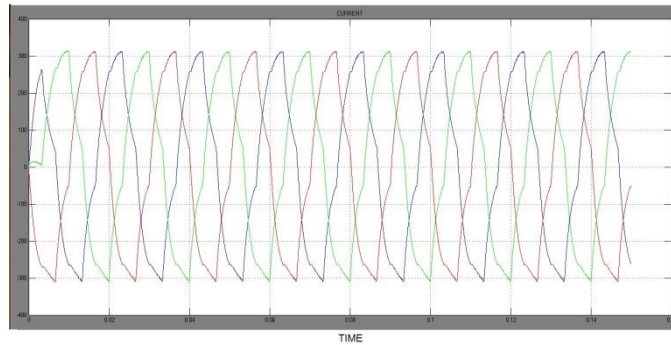

**Fig. 8** Current waveform

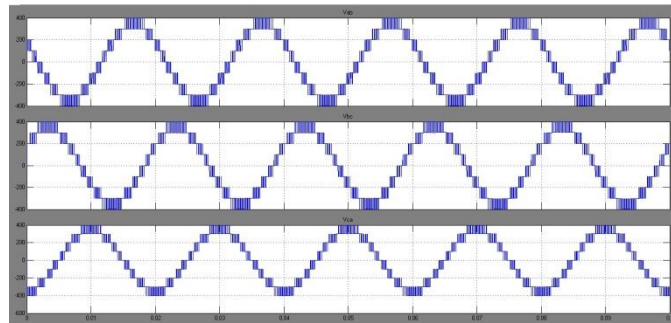

**Fig.8** line voltage for the 5 level inverter.

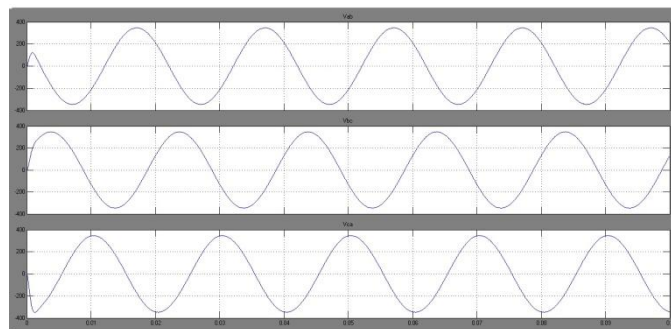

**Fig.10** filtered line Voltage waveform of the 5 level inverter

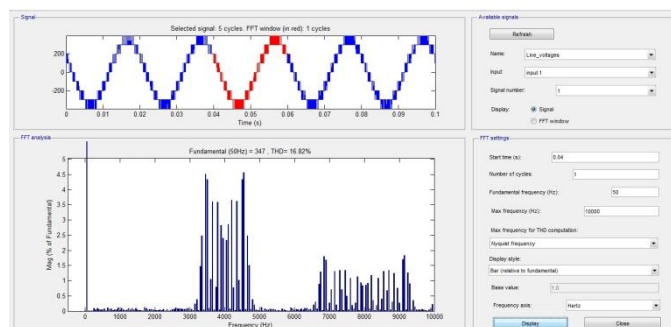

**Fig.11** THD waveform for the 5 level inverter

#### **IV. Conclusion**

In the proposed paper, a 2 level based 5 level SVPWM has been implemented. Since the implementation is very simple, it can be easily implemented using DSP processor. In the proposed paper, LC filter has also been designed for the reduction of harmonics. With the usage of LC filter and SVPWM, we are able to obtain the THD of about 0.28%.

#### **References**

- [1]. Fang Zheng Peng and Jih-Sheng Lai "A multilevelvoltage-source inverter with separate DC sources for static VAr generation" Industry ApplicationsConference, 1995. Thirtieth IAS Annual Meeting, IAS'95., Conference Record of the 1995IEEE (Volume:3 ), 8-12 Oct 1995.
- [2]. J. Rodriguez, J. S. Lai, and F. Z. Peng, "Multilevel inverters: A survey of topologies, controls, and applications," IEEE Trans. Ind. Electron. Ol. 49, no. 4, pp. 724–738, Aug. 2002.
- [3]. Amit Kumar gupta, and ashwin m khambadkone," A Space Vector PWM Scheme for Multilevel Inverters Based on Two-Level Space Vector PWM," IEEE TRANSACTIONS ON INDUSTRIAL ELECTRONICS, VOL. 53, NO. 5, OCTOBER 2006
- [4]. S. K. `, J. O. P. Pinto, and B. K. Bose, "A neural-networkbased space-vector pwm controller for a three-level voltage-fed inverter induction motor drive," IEEE Trans. Power Electron., vol. 38, no. 3,pp. 660–669, May/Jun. 2002.
- [5]. N. Celanovic and D. Boroyevich, "A fast space vector modulation algorithm for multilevel three phase converters," IEEE Trans. Ind. Appl.,vol. 37, no. 2, pp. 637–641, Mar./Apr. 2001.