

Ethernet Controller as Solution for Embedded Applications, New Developments and Innovations

Mahesh Yanagimath¹, Purnima Savadattimath², Balawant Patil³

¹(Department of Electrical and electronics Engineering, Hirasugar Institute of Technology, Nidasoshi.)

²(Department of Electrical engineering Shri Ulavi channabasaveshwar Polytechnic college, Dandeli)

³(Department of Electrical and electronics Engineering, Gogte Institute of Technology, Belgaum.)

ABSTRACT : Ethernet is the networking technology used in many offices and homes to enable computers to communicate and share resources. Recent innovations in the Ethernet networking technology are enhancing both the scalability and capability of Ethernet as a carrier-grade and transport technology. This paper explains four main innovations recently added to ethernet, namely improvements related to scalability, OAM functionality and enhanced forwarding capability in order to permit Ethernet to assume a much larger role in carrier networks with substantial economic and operational benefits.

Keywords - Optical Ethernet, Networks, Protocols, Communication Systems, Optical Communication

I. INTRODUCTION

Ethernet is the most widely deployed network in offices and industrial buildings. Ethernet's infrastructure, interoperability and scalability ensure ease of development. And, Once equipment is connected to a Ethernet network, it can be monitored or controlled through the Internet removing any distance barrier that may have inhibited remote communication previously. Ethernet-based networking technology has become ubiquitous in both the enterprise and home broadband areas. The combination of simplicity and rigorous specification has permitted a degree of integration and commoditization that other networking technologies have been unable to achieve. However, some service providers infrastructure is based on a legacy circuit-based infrastructure, using technologies like SDH, frame relay and ATM to provide private lines services and interconnection. This has placed service providers in a difficult position, as they face both the costs of supporting multiple technologies and a service arbitrage situation they sell the same service on multiple technology platforms.

Ethernet is the technology of choice in the customer domain and is therefore a desirable choice in the service-provider domain to eliminate potential inter working problems and leverage the customer-driven investment. However, every technology transformation in the service provider space is time-consuming and also represents major commitment; consequently, comprehensive functionality is required as a prerequisite to mass deployment. From a carrier's perspective, Ethernet still has deficiencies with respect to OAM, reliability, traffic management, and scalability.

It turns out that many of the fundamental issues with Ethernet are well understood, and are currently being addressed with the same rigor and drive for simplicity that has been the objective of Ethernet to date. This article dives into the challenges faced, and how existing Ethernet behaviors can be combined with standards in progress in order to provide a comprehensive network infrastructure that will address the carrier's concerns.

I. CHALLENGES TO ETHERNET

While end customers are convinced of Ethernet's cost benefits, they are demanding the same levels of performance they had from leased lines, Frame Relay and ATM services. For Ethernet to reach the kind of penetration predicted by analysts, it is required that Ethernet should evolve to display the same properties of current WAN technologies. The Metro Ethernet Forum (MEF) has defined this evolution as "Carrier Ethernet", which should have the following attributes:

1. **Scalability** — Providers require that the network scale to support the 100,000s of customers to adequately address metropolitan and regional served areas.
2. **Protection** — This really implies reliability and resiliency, as service providers typically boast "five 9's" 99.999 percent network availability. One of the benchmark tools for achieving this has been SONET/SDH's ability to provide 50ms link recovery, as well as protection mechanisms for nodal and end-to-end path failures. For Carrier Ethernet to be adopted especially in support of converged, real-time applications it must match these performance levels seen by traditional WAN technologies.
3. **Hard Quality of Service (QoS)** — Service providers must be able to offer customers differentiated levels of

service to match application requirements. QoS mechanisms provide the functionality to prioritize different traffic streams, but Hard QoS ensures that service level parameters agreed for each level of service are guaranteed and enforced across the network. This provides customers with the guaranteed, deterministic performance they receive from their existing leased line services.

4. Service management — Service providers require mature network and service management systems that firstly allow quick services provisioning in order to deliver existing and new services and secondly monitoring different parameters of the provided services. Such monitoring is used against an SLA and the service provider must have the performance measurements to back up any service level claims. And if a fault does occur, the service provider needs to have the troubleshooting functionality to locate the fault, identify which services have been impacted and react appropriately.

Equipment vendors are challenged with how to add this carrier-grade functionality to Ethernet equipment without losing the cost-effectiveness and simplicity that make it attractive in the first place. In the next chapters, we will examine the different technologies that are designed to achieve this.

III. ETHERNET TECHNOLOGIES

The Metro Ethernet Forum has defined Ethernet services using the concept of Ethernet Virtual Connections (EVC) established across an Ethernet Network. Customer Equipment (CE) attaches to the network at the User-Network Interface (UNI) using standard 10Mbps, 100Mbps, 1Gbps or 10Gbps Ethernet interfaces. There are three types of EVCs defined: 1. Point-to-Point, called E-Line 2. Point to Multi point, called E-Tree 3. Multipoint-to-Multipoint, called E-LAN. In order to provide such services, different Ethernet technologies have been proposed and are used for the delivery of the previous services.

A. IEEE 802.1Q Virtual LAN (VLAN)

The basic technology standard used for delivering an ELAN service is the IEEE 802.1Q standard for Virtual LANs (VLANs). This standard creates VLANs across a common LAN infrastructure to enable enterprises to support and separate traffic from different departments within a company (for example finance, legal and general administration). Each VLAN is identified by a Q-tag (also known as a VLAN tag or VLAN ID) that identifies a logical partitioning of the network to serve the different communities of interest.

IEEE 802.1Q works fine within the boundaries of a single organization, but is found inadequate when service providers attempt to deliver Ethernet services to multiple end users over a shared network infrastructure. Issues arise because enterprises need to retain control over their own VLAN administration (such as assigning Q-tags to VLANs), and over a shared infrastructure the service provider must control this to ensure that one customer's Q-tags do not overlap with another's. Also, because the Q-tag consists of a 12-bit tag, up to 4,094 possible service instances can be created. (Note: 4,096 service IDs are available, but two of these are reserved for administration.) Although this is sufficient for an enterprise's LANs, it does not offer the scalability required to support Ethernet services in a large metropolitan area. What is needed is a method for defining secure Ethernet services to individual customers within which the customer can create further LANs for departments or groups of users. There are two developing standards that support this approach: IEEE 802.1ad Provider Bridges (also known as Q-in-Q or VLAN stacking) and IEEE 802.1ah Provider Backbone Bridges [4] (also known as MAC-in- MAC).

The standardization of these technologies is being driven by the IEEE 802.1 working group. The Provider Bridges standard was officially approved in December 2005, while Provider Backbone Bridges was formally introduced as draft standard in March 2005 and it is expected to be officially approved in the second quarter of 2008.

B. IEEE 802.1ad Provider Bridges (Q-in-Q)

Provider Bridges work by simply adding an additional service provider VLAN ID (S-VID) to the customer's Ethernet frame. This new S-VID tag is used to identify the service in the provider network while the customer's VLAN ID (C-VID) remains intact and is not altered by the service provider anywhere within the provider's network as shown in Figure 1. This solves the transparency problem experienced by IEEE802.1Q.

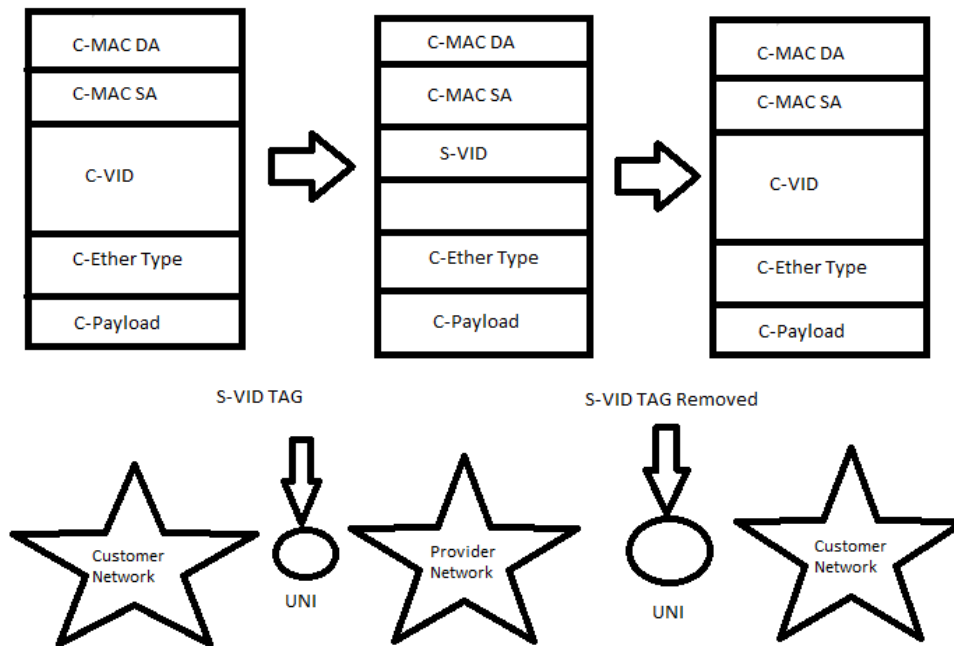

Figure 1. S-VID Added to customer frame.

Provider Bridges use the S-VID to identify the service to which a customer’s Ethernet frames belongs to and therefore each service instance requires a separate S-VID. Because the S-VID consists of a 12-bit tag, Provider Bridges has the same scalability limitation of IEEE 802.1Q and only 4,094 services instances can be created.

In addition, Provider Bridges uses the same MAC address for the provider’s and customers’ networks. This makes both networks appear as one large network to the provider’s switches, as shown in Figure 2.

In the scenario depicted in Figure 2, the provider’s and customers’ MAC addresses are visible to all network elements and this creates a significant burden for core switches, as they must maintain a forwarding table for every MAC address in the service provider and customer networks. Also, any changes to the customer network will have an impact on the provider core. For example, when a new host is added in the customer’s network, the new MAC address must be learned by the provider’s switches, or when a failure occurs in the customer network, the resulting action taken by Spanning Tree Protocol (STP) can impact the provider network. Although such changes are outside the service providers network, yet they impact their network and create instability. From the customers’ perspective, a potential security concern emerges from the fact that their addressing information is now visible outside of their secure network domain.

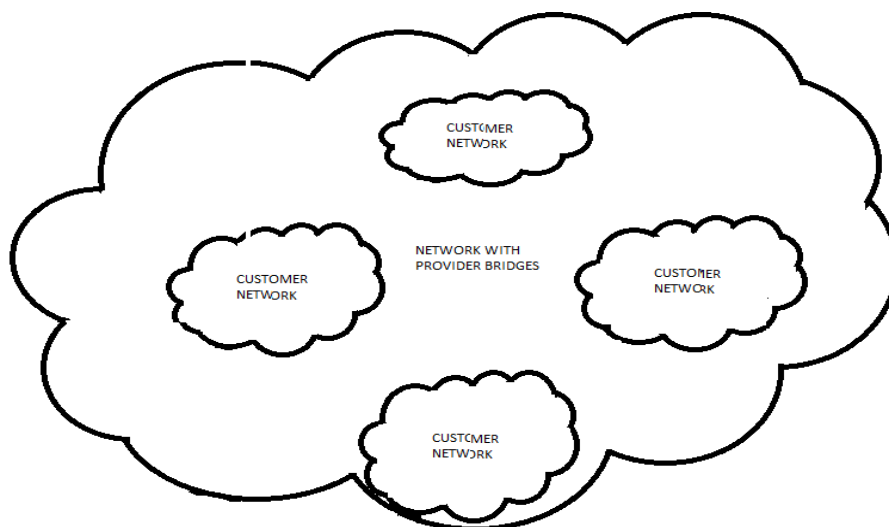

Figure 2. Provider’s and customer’s MAC addresses visible to all networks.

Provider Bridges does not provide separation between the provider and customer networks and this creates problems where control protocols are concerned. Most Ethernet control protocols, such as Bridged Protocol Data Units (B-PDUs) used by customer networks, must not interact with the provider's networking equipment. For example, STP used in the customer network must not interact with STP used in the provider network. B-PDUs are identified by their destination MAC address and do not have a VLAN tag associated with them. For example, the Spanning Tree Protocol is identified by destination MAC address 01-80-C2-00-00-00. Provider Bridges cannot provide differentiation between customer and provider B-PDUs because each entity's B-PDUs have the same MAC address, and duplicate MAC addresses cannot be supported. This will cause unpredictable network behavior because the provider's networking equipment cannot distinguish between customer and provider B-PDUs. IEEE standard solves this limitation by introducing a different set of destination MAC addresses for B-PDUs in the provider's network. However, to support these new provider B-PDU MAC addresses, the service providers must replace the existing Ethernet switches, because B-PDU MAC addresses are not configurable. For this reason, Provider Bridges technology has significant limitations for E-LAN services that must support multiple customer control protocols.

IV. ADDING TRAFFIC ENGINEERING TO ETHERNET

It is now possible to support connection-oriented forwarding using native Ethernet with a new technology called Provider Backbone Bridges – Traffic Engineering (PBB-TE). PBB-TE is an innovative Ethernet technology, invented by Nortel with the former name PBT, currently being standardized as part of IEEE 802.1Qay and that proposes only minor addition to the existing Ethernet standards. In its simplest form, PBBTE provides Ethernet tunnels that enable deterministic service delivery with the traffic engineering, QoS, resiliency and OAM requirements that service providers demand.

PBB-TE takes advantage of the fact that by simply turning off some Ethernet functionality, the existing Ethernet hardware is capable of a new forwarding behavior. This means that a connection-oriented forwarding mode can be introduced to current Ethernet networks without complex and expensive network technologies. Currently, Ethernet switches forward on the basis of a full 60-bit lookup of both the VLAN tag (12 bits) and the destination MAC address (48 bits) in each Ethernet frame. In conventional operation, both the VLAN ID (VID) and MAC address are globally unique, but this doesn't have to be the case. Where a VID typically identifies a loop free multicast domain in which MAC addresses can be flooded, if we choose to configure loop free MAC paths instead, the VID is freed up to can be used to denote something else. In the case of PBBTE, it will use a range of VIDs to identify specific paths through the network to a given destination MAC address. Each VID is then locally significant to the destination MAC address only, and since the MAC address is still globally significant, the combination of VID + MAC (60 bits) becomes globally unique.

PBB-TE allocates a range of VID/MAC addresses whose forwarding tables are populated via the management or control plane instead of through the traditional flooding and learning techniques. In this case, Spanning Tree and all its associated constraints and problems disappear. The switches still behave fundamentally as with traditional Ethernet: forwarding data to its intended destination. What is different is the fact that the forwarding information is no longer based on the MAC learning mechanisms of the switches, but is provided directly by the management plane, resulting in a prescribed, predetermined path through the network and totally predictable network behavior under all circumstances.

V. ADDING OAM TO ETHERNET

OAM functionality in traditional TDM networks is well defined and is an important building block in ensuring that operators can deliver "carrier grade" performance services. Traditional Ethernet in the LAN environment does not have the OAM functionality required by network operators in Metropolitan and Wide Area Networks environment. If Carrier Ethernet is to fulfill its promise as the next generation packet-based infrastructure for metropolitan and wide area networks, OAM capabilities must be added to Ethernet. New standards that provide Ethernet with OAM capabilities is described in the next chapters.

A. Fault management

There are two main areas of OAM: fault management and performance monitoring. Fault management ensures that when a defect occurs in the network, it is reported to the operator, who can then take the appropriate action. This is divided into the following functions:

1. **Fault Detection** — IEEE 802.1ag [10] and ITU-T Y.1731 support fault detection through Continuity Check Messages (CCM). These allow endpoints to detect an interruption in service. CCMs are sent from the source to destination node at periodic intervals; if either end does not receive a CCM within a specified duration, then a fault is detected against the service.

2. **Fault verification** — IEEE 802.1ag and ITU-T Y.1731 support fault verification through Loopback Messages (LBM) and Loopback Reply (LBR). These can be used during initial set-up or after a fault has been detected to verify that the fault has occurred between two end points.
3. **Fault isolation** — IEEE 802.1ag and ITU-T Y.1731 support fault isolation through Link trace Messages (LTM) and Link trace Reply (LTR).
4. **Fault notification** — ITU-T Y.1731 supports fault notification through Alarm Indication Signal (AIS).

B. Performance monitoring

In many respects the fault management concepts above have been adopted from existing practices in traditional TDM networks. However, while connection-orientated TDM services offer customers a predictable and guaranteed service, packet or frame-based services are connectionless and can have varying performance levels. This is because each individual frame in a service can suffer varying delays due to possible queuing, while network congestion can result in actual loss of frames. Specially, video and voice services, which are part of a residential triple play bouquet, are particularly susceptible to the effects of latency and jitter. As a result, Carrier Ethernet networks require advanced performance monitoring to enforce customer SLAs and this functionality is introduced by ITU-T Y.1731. The following functionality is included:

1. **Frame Loss Ratio** — ITU-T Y.1731 calculates frame loss by sending transmit and receive counters within the CCM for dual-ended measurements. The far end counters can then be compared with those produced locally to derive frame loss as a percentage.
2. **Frame Delay** — Similarly, ITU-T Y.1731 calculates frame delay (or latency). The receiving end can derive the time delay experienced across the network. This requires each service end point to have synchronized clocks.
3. **Frame Delay Variation** — Finally, ITU-T Y.1731 calculates frame delay variation (or jitter) by tracking frame delay measurements.

The emergence of carrier-grade Ethernet has driven the need for improved Ethernet OAM functionality. Ethernet OAM allows the exchange of management information from the network elements to the management layer. Without this capability, it is impossible to provide the comprehensive network management functionality that operators have today in their TDM networks.

VI. CONCLUSIONS

Traditionally, Ethernet lacks of some capabilities to become a technology deployed in the Metropolitan and Wide Area Network environment. However, recent innovations like PBB, PBB-TE and OAM, allow operators to consider Ethernet as a carrier grade networking technology alternative to the traditional technologies like SONET/SDH, ATM or MPLS.

Provider Backbone Bridges (IEEE 802.1ah) provides carrier-grade scalability, resiliency and security between the service provider and customer. Provider Backbone Bridging –Traffic Engineering is then employed in the service provider domain, creating the ability to configure resilient, SLA-driven point-to-point Ethernet trunks. Finally, the combination of IEEE 802.1ag and ITU-T Y.1731 provides powerful fault management and performance monitoring capabilities to Ethernet.

These developments allow service providers to offer scalable, differentiated Ethernet services while retaining Ethernet's cost points and operational simplicity.

However, even with all the improvements that have described in the previous chapters, Ethernet still has one significant weakness. Ethernet still relies on Spanning Tree protocol for any-to-any connectivity, which brings with it several undesirable behaviors. For example, in order to maintain loop free topologies, links are blocked and not used, therefore compromising network capacity. In addition, changes in the network topology such as those resulting from link failures can have a significant impact on the state of the entire network during re-convergence. New innovations are addressing this key issue. A new technology called Provider Link State Bridging (PLSB) which is based on Link State, can resolve the problems described above. PLSB removes the need of Spanning Tree, and through the use of a Link State Protocol, allows much faster network convergence (hundreds of milliseconds versus several seconds), as well as broadcast containment for PBB ELAN services.

REFERENCES

- [1] IEEE Std. 802.1D, "Local and Metropolitan Area Networks, Media Access Control (MAC) Bridges," 2004.
- [2] IETF Internet draft, "GMPLS control of Ethernet PBB-TE," Nov. 2007 (work in progress), available at draft-fedyk-gmpls-ethernet-pbb-te-02
- [3] IETF Internet draft, "Carrying PWE3 Pseudo Wires over Provider Backbone Transport," July 2007 (work in progress) available at draftallan-pw-o-pbt-03.txt.
- [4] <http://www.ieee802.org/1/files/public/docs2007/aqfedyk-provider-link-state-bridging-0107-1.pdf>
- [5] <http://www.nortel.com/pbt>
- [6] Embedded Ethernet and Internet Complete, Designing and Programming small Devices for Networking, By Jon Axelson.