

Channel Equalization of WCDMA Downlink System Using Finite Length MMSE-DFE

Sandip Das¹, Soumitra Kumar Mandal²

¹(Electronics and Communication Engg Dept., University of Engineering and Management, Jaipur, India)

²(Electrical Engineering Dept., NITTTR Kolkata, India)

Abstract: The performance of WCDMA system deteriorates in the presence of multipath fading environment. Fading destroys the orthogonality and is responsible for multiple access interference (MAI). Though conventional rake receiver provides reasonable performance in the WCDMA downlink system due to path diversity, but it does not restore the orthogonality. Linear equalizer restores orthogonality and suppresses MAI, but it is not efficient, since its performance depends on the spectral characteristics of the channel. To overcome this, Minimum Mean Square Error- Decision Feedback Equalizer (MMSE-DFE) with a linear, anticausal feedforward filter, causal feedback filter and simple detector is proposed in this paper. The filter taps of finite length DFE is derived using the cholesky factorization theory, capable of suppressing noise, Intersymbol Interference (ISI) and MAI. This paper describes the WCDMA downlink system using finite length MMSE-DFE and takes into consideration the effects of interference which includes additive white gaussian noise, multipath fading, ISI and MAI. Furthermore, the performance is compared with conventional rake receiver and MMSE and the simulation results are shown.

Keywords – MMSE, MMSE-DFE, rake receiver, WCDMA

I. INTRODUCTION

During the period of last one decade, the large demands for wireless services and high data speeds have driven the wireless cellular networks to a tremendous growth. To support high-speed data rates and more importantly, to provide multimedia services efficiently, the International Telecommunications Union-Radio Communication Sector (ITU-R) undertook the task of defining a set of recommendations for International Mobile Telecommunication in the year 2000 (IMT-2000). UMTS was proposed with WCDMA as the air interface. In this system Rake is a popular and effective receiver utilizing temporal diversity in the presence of multiple effects. But, its performance is limited by Multiple Access Interference (MAI) because of the disability for separating Additive White Gaussian Noise (AWGN) from MAI [1]. UMTS uses orthogonal spreading sequences which are time-varying due to the embedded scrambling code. These time-varying spreading sequences cause severe problems when applying multiuser detection, e.g. symbol-level minimum mean-squared error (MMSE) multiuser equalization according to [2], because the receiver filter has to be recalculated at each symbol interval. To overcome this requirement, it was proposed in [3], [4] to apply linear MMSE channel equalization [5] with finite impulse response (FIR) filters at chip level on the CDMA downlink followed by a simple correlation with the spreading sequence of the desired user. Substantial improvements in performance are obtained by using convolutional codes jointly with the adaptive space-time MMSE receiver [6]. In this paper, a Decision Feedback Equalizer is introduced whose filter coefficients are derived under the MMSE criteria by making the error orthogonal to the received sequence. The ideal, infinite-length feed-forward filter is a noise whitening filter that results in an overall response with minimum phase. Choosing an infinite-length filter eliminates the delay optimization, because the overall response, consisting of transmit, channel, receiver, sampler, and feed forward filters is simply a filter with minimum phase. Cholesky factorization theory is used to derive the finite length equivalent of the infinite tap Decision Feedback Equalizer.

II. SYSTEM MODEL

In WCDMA downlink the users are spread twice in succession—first with channelization code and later with the scrambling codes. In this channelization operation, the number of chips per data symbol is called the Spreading Factor (SF) [7]. The channelization codes are used for separation of the different downlink physical channels within one cell. In each cell the same set of channelization codes is used. UMTS supports data rates ranging from 15 kbps to 1920 kbps for DPDCHs corresponding with SFs ranging from 512 to 4 and data rates ranging from 30 kbps to 1920 kbps for PDSCHs, corresponding with SFs ranging from 256 to 4 [8]. The second spreading operation is the scrambling operation, where a base station specific scrambling code is applied to the already spread signal [9][10]. Finally the scrambled signal is pulse-shape filtered using a root raised cosine filter with a roll-off factor of 0.22 [11]. After pulse shape filtering the signal is QPSK modulated and transmitted

through the modeled channel. The K user data after the spreading operation can be written as:

$$x[n] = \sum_{k=1}^K \sum_{m=0}^{M-1} X_k(m) \underbrace{S_m^k(t - mT_m^k)}_{S_d(t)} \tag{1}$$

Where, K stands for number of active users, $S_d(t)$ is the data signals (of Dedicated Physical Channels). M_k is the number of data symbols in a frame sent to user K in the burst. The user K spreading waveform is denoted by, $S_m^k(t)$. Where $S_m^k(t)$ is defined as:

$$\begin{aligned} S_m^k(t) &= \frac{1}{\sqrt{N_k}} \sum_{i=0}^{N_k-1} W_k^{ch}(i) C_{scr}(i + mN_k) p(t - iT_c) \\ &= \frac{1}{\sqrt{N_k}} \sum_{i=0}^{N_k-1} W_k^{ch}(i) C_k(i, m) p(t - iT_c) \end{aligned} \tag{2}$$

Where, N_k is the user specific spreading factor. The data symbols are spread $W_k^{ch}(i)$ and then scrambled by scrambling code (Gold Code) $C_{scr}(i)$. The two codes are mixed in a single time-varying and user k specific spreading code, $C_k(i, m)$. The chip shaping filter $p(t)$ is a square root raised cosine pulse of roll off factor $\rho=0.22$, and T_c is the chip duration.

The channel is modeled as time invariant FIR filter $h(z^{-1})$ given as:

$$h(z^{-1}) = h_0 + h_1 z^{-1} + h_2 z^{-2} + \dots + h_{n-1} z^{n-1} \tag{3}$$

or,

$$h(\tau) = \sum_l^{L-1} (\tau - \tau_l) \tag{4}$$

Where, z^{-l} is the unit delay operator and n is the tap length and $h_0, h_1, h_2, \dots, h_{n-1}$ are the complex impulse response of the channel in (3) and τ_l is the path delay and L represents the total number of paths in (4).

The signal received at the mobile station after propagating through the modeled channel given by (4) can be represented as:

$$y(t) = \sum_{l=0}^{L-1} hx(t - d_l) + v_d(t) \tag{5}$$

Assuming the described transmission model, a MMSE-DFE is introduced in the following section whose filter taps are calculated using cholesky factorization theory.

III. MMSE-DECISION FEEDBACK EQUALIZER

In this section a Decision Feedback Equalizer is introduced, whose feed forward and feedback filter taps are derived under minimum mean square criteria using cholesky factorization. The received signal given in (5), can be represented as:

$$\begin{aligned} y_k &= \begin{pmatrix} y(k + ((n-1)/n)T) \\ \dots \dots \\ \dots \dots \\ y(kT) \end{pmatrix} = \begin{pmatrix} y_{n-1,k} \\ \dots \dots \\ \dots \dots \\ y_{0,k} \end{pmatrix} \\ h_l &= \begin{pmatrix} h(l + ((n-1)/n)T) \\ \dots \dots \\ \dots \dots \\ h(lT) \end{pmatrix} = \begin{pmatrix} h_{n-1,k} \\ \dots \dots \\ \dots \dots \\ h_{0,k} \end{pmatrix} \\ v_k &= \begin{pmatrix} v(k + ((n-1)/n)T) \\ \dots \dots \\ \dots \dots \\ v(kT) \end{pmatrix} = \begin{pmatrix} v_{n-1,k} \\ \dots \dots \\ \dots \dots \\ v_{0,k} \end{pmatrix} \end{aligned} \tag{6}$$

Where n is the oversampling factor, y_k is the received samples, h_l is the channel and v_k is the noise samples. By combining N_f successive n-tuples of samples y_k :

$$\begin{pmatrix} y_k + N_f - 1 \\ y_k + N_f - 2 \\ \dots \\ y_k \end{pmatrix} = \begin{pmatrix} h_0 & h_1 & \dots & h_l & 0 & \dots & 0 \\ 0 & h_0 & h_1 & \dots & h_l & 0 & \dots \\ \dots & \dots & \dots & \dots & \dots & \dots & \dots \\ 0 & \dots & 0 & h_0 & h_1 & \dots & h_l \end{pmatrix} \begin{pmatrix} x_k + N_f - 1 \\ x_k + N_f - 2 \\ \dots \\ x_{k-v} \end{pmatrix} + \begin{pmatrix} v_k + N_f - 1 \\ v_k + N_f - 2 \\ \dots \\ v_k \end{pmatrix} \quad (7)$$

A more compact representation of (7) is expressed in (8).

$$y_k + N_{f-1,k} = Hx_{k+N_{f-1,k-l}} + n_{k+N_{f-1,k}} \quad (8)$$

Where N_f is the number of feed forward filter taps.

The equalizer output error is expressed as:

$$e_k = b^*x_{k,k-l} - w^*y_{k+N_{f-1,k}} \quad (9)$$

The w^* feed forward filter taps are expressed as:

$$w^* = [w_{-(N_f-1)}^* \ w_{-(N_f-2)}^* \ \dots \ w_0^*] \quad (10)$$

For a decision delay of Δ , the corresponding MMSE is expressed as:

$$E\{|e_k|^2\} = E\{e_k \cdot e_k^*\} = E\{(x_{k-\Delta} - wY_k + bx_{k-\Delta-1})(x_{k-\Delta} - wY_k + bx_{k-\Delta-1})^*\} \quad (11)$$

The coefficients for the feedback FIR filter, b is:

$$b = [1 \ b_0 \ \dots \ b_{N_b}] \quad (12)$$

Applying the orthogonal principle by making the error orthogonal to the output we get:

$$E\{e_k \cdot Y_k^*\} = 0 \quad (13)$$

In other words, the optimum error sequence is uncorrelated with the observed data. This simplifies to (14), which gives the relation between the DFE feedback and feed forward filter coefficients.

$$b^*R_{xy} = w^*R_{yy} \quad (14)$$

The FIR MMSE-DFE autocorrelation matrix is expressed as:

$$R_{yy} = [E\{Y_{k+N_{f-1,k}} Y_{k+N_{f-1,k}}^*\}] = S_x H H^* + R_{vv} \quad (15)$$

Where $R_{vv} = N_0 I_{N_f}$ and N_0 is the noise power, I is an identity matrix, and S_x is the signal power. The input-output cross-correlation matrix is given as:

$$R_{xy} = E[x_{k,k-l} y_{k+N_{f-1,k}}^*] = S_x [0 \ I_{(l+1)(N_f-1)} \ \dots \ I_{(l+1)}] H \quad (16)$$

The mean-square error is expressed as:

$$(R_{xx} - R_{xy} R_{yy}^{-1} R_{yx}) = S_x [0 \ I_{l+1}] [I_{N_{f+l}} - H^* (H H^* + \frac{1}{SNR} I_{N_{f-l}})^{-1} H] \quad (17)$$

Simplifying (17) by using the matrix inversion lemma results in (18):

$$S_x [0 \ I_{l+1}] [I_{N_{f+l}} - H^* (H H^* + \frac{1}{SNR} I_{N_{f-l}})^{-1} \begin{bmatrix} 0 \\ I_{l+1} \end{bmatrix}] = N_0 [0 \ I_{l+1}] (H H^* + \frac{1}{SNR} I_{N_{f+l}})^{-1} \begin{bmatrix} 0 \\ I_{l+1} \end{bmatrix} \quad (18)$$

The middle term in the right-hand side of (19), is defined as a Cholesky factorization, where LDL^* is the Lower-Diagonal-Upper.

$$R_{xx}^{-1} + H^* R_{vv}^{-1} H = (R_{xx} - R_{xy} R_{yy}^{-1} R_{yx})^{-1} \frac{1}{SNR} I_{N_{f+l}} + H^* H = LDL^* \quad (19)$$

Where L is a lower-triangular monic matrix, D is a diagonal matrix as shown:

$$L = \begin{bmatrix} I_0 & \dots & I_{N_{f+l-1}} \end{bmatrix}$$

$$L^{-1} = \begin{bmatrix} u_0 \\ \dots \\ u_{N_{f+l-1}} \end{bmatrix}$$

$$D = \begin{bmatrix} d_0 & \dots & 0 \\ 0 & \dots & 0 \\ 0 & \dots & d_{N_{f+l-1}} \end{bmatrix} \quad (20)$$

Because L is a monic matrix, its columns constitute a basis for the (N_f+l) dimensional vector space. The optimal setting for b is column L which corresponds to the highest value of “ d ” in the diagonal matrix. When the feedback coefficients are located, the solution expressed in (21), gives the optimal setting for w , the feed forward coefficient.

$$w_{opt}^* = b_{opt}^* R_{xy} R_{yy}^{-1} \quad (21)$$

The first coefficient of b is always unity, therefore a simple back substitution is used to solve for the feed forward coefficients.

The feed forward filter coefficients, w , derived are used to process the received signal and the feedback filter coefficients, b , processes the previous estimates as shown in Fig.1.

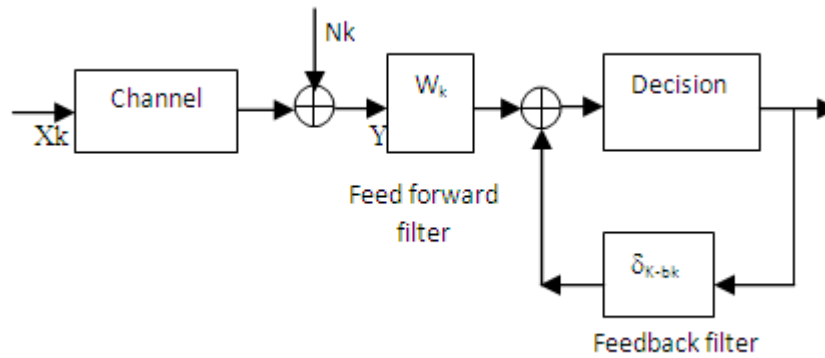

Fig.1. Block Diagram of DFE

IV. NUMERICAL RESULTS AND DISCUSSIONS

In this section the performance of MMSE-DFE is compared with conventional rake receiver and MMSE. The WCDMA downlink system is simulated using Matlab R2010a. The considered Rayleigh multipath channel has five important delayed paths having equal average power. Ten radio frames, each of 10ms long, are transmitted with spreading code of 16 and 32 respectively. The number of bits transmitted in a frame depends on the spread factor and can be calculated as $15 \cdot 10 \cdot 2^k$, where parameter k is related to spreading factor given by $SF = 512/2^k$ [12][13]. Thus when SF=16, number of bits transmitted in ten radio frames is 48000 and when SF=32, number of bits transmitted in ten radio frames is 24000. The modulation technique used in the simulations is QPSK modulation and the terminal velocity is set to 60Km/h. In the receiver side, the feed forward filter order and the feedback filter of MMSE-DFE is taken as 24.

Fig.2 and Fig.3 shows the BER vs SNR performance of MMSE-DFE compared to conventional rake receiver and MMSE equalizer. From both the figure it is clear that MMSE-DFE is the efficient equalizer compared to MMSE equalizer and conventional rake receiver. The MMSE-DFE considerably reduces the bit error rate and outperforms MMSE equalizer and MMSE-DFE.

From Fig.2 and 3 it is seen that SNR of 10dB and 8dB is required to achieve the BER of 10^{-2} by MMSE equalizer for spreading factor 16 and 32 respectively, whereas MMSE-DFE need SNR of 8.5 dB and 6dB to achieve BER of 10^{-2} for spreading factor 16 and 32 respectively and SNR of 16dB and 12 dB to achieve the BER of 10^{-3} for spreading factor 16 and 32 respectively.

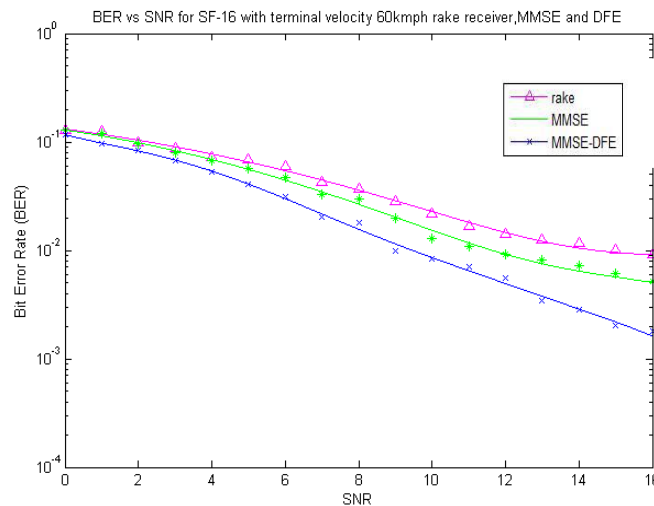

Fig. 2 BER vs SNR for SF=16 with terminal velocity 60Km/h for rake receiver, MMSE and MMSE-DFE

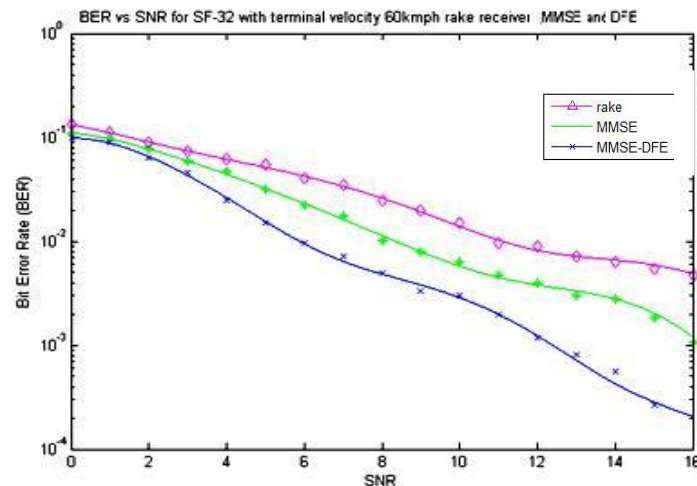

Fig. 3 BER vs SNR for SF=32 with terminal velocity 60Km/h for rake receiver, MMSE and MMSE-DFE

V. CONCLUSION

This paper has demonstrated MMSE-DFE for WCDMA downlink system, which is capable of reducing the MAI and restoring the orthogonality of the users. MMSE-DFE is compared with conventional rake receiver and MMSE for different terminal velocities and varying spreading factors. Simulation result shows that MMSE-DFE is an efficient equalizer compared to conventional rake receiver and MMSE and improves the performance of WCDMA downlink system. Further work is required in order to realise adaptive implementations of MMSE-DFE for downlink WCDMA system.

REFERENCES

- [1]. T. L. Fulghum, D. A. Cairns, C. Cozzo, Y. P. E. Wang, and G. E. Bottomley, Adaptive generalized rake reception in DS-CDMA systems, *IEEE Transactions on Wireless Communications*, 8(7), 2009, 3464–3474.
- [2]. John G. Proakis, Digital Communications (Mc Graw Hill, International Edition, 2001).
- [3]. Thomas P. Krauss, Michael D. Zoltowski, Geert Leus, *Simple MMSE Equalizers for CDMA downlink to restore chip sequence: Comparison to zero forcing and RAKE*, Proc. IEEE Conf. on Acoustic Speech and Signal Processing, Istanbul, Turkey, 2000, 2865-2868.
- [4]. Irfan Ghauri, Dirk T.M. Slock, Linear Receivers for the DS-CDMA downlink exploiting the orthogonality of spreading sequences, *Conference record of thirty third Asilomar conference on Signal Systems and Computers*, Pacific Grove, California, 1998, 650-654.
- [5]. R.N. Lucky, J.Salz, E.J. Jr., Principles of Data Communication (New York, Mc Graw Hill, 1968). A. Trivedi and D. K. Mehra, Convolutionally coded adaptive space-time MMSE receiver for W-CDMA systems in multipath channels, *IETE Journal of Research*, 53(2), 2007, 137–151.
- [6]. Ahmad M. Alsolaim, *Dynamically reconfigurable architecture for third generation mobile systems*, doctoral diss., College of Engineering and Technology, Ohio University, 2002.
- [7]. Jordy Potman, Fokke Hoeksema and Kees Slump, Trade offs between Spreading factor, Symbol Constellation size and Rake Fingers in UMTS, available at doc.utwente.nl/46690/1/potman03tradeoffs.pdf.
- [8]. T. Ojanpera and R. Prasad, An overview of Third Generation wireless personal communication: An European Perspective, *IEEE Personal Communication*, 1998, 59-65.
- [9]. L.D. Brown, H. Hua, G. Chunyu, A widget Framework for Augmented interaction in SCAPE, *Proc. of the 16th annual ACM Symposium on User interface software and technology*, 2003, 1-10.
- [10]. 3GPP, UMTS; UTRA (BS), FDD; Radio Transmission and reception, Technical report, ETSI TS 125 104 V5.4.0, September, 2002
- [11]. 3GPP Technical specifications, Physical layer procedures (FDD), 3GPP document No. 3GTS25.214, ver. 3.2.0, 2000.
- [12]. 3GPP Technical specifications, 2000, “Physical layer general description”, 3GPP document No. 3GTS25.201, ver. 3.2.0